

# Impact of gear rim narrowing angle on the temperature and sound pressure of Beveloid gear pair made of polymeric materials

Piotr STROJNY\*

The Faculty of Mechanical Engineering and Aeronautics, Rzeszow University of Technology,  
 al. Powstańców Warszawy 12, 35-959 Rzeszów, Poland

**Abstract.** The paper contains a description of the geometry of Beveloid gears. It describes the distribution of forces in a Beveloid gear with a straight tooth line and a helical tooth line. The paper presents research on the experimentally determined parameters of transmission operation, including the sound pressure level and the amount of heat emitted during operation. The design and construction of the test stand were presented. The research methodology was described. Operational tests are carried out on household appliances with Beveloid gears: Grinder and Jam mixer. Thanks to an appropriately selected narrowing angle, estimated values of service life extension of the above-mentioned transmissions are given.

**Key words:** helical transmissions; operation; polymeric materials; sound pressure; the operating temperature of a Beveloid gear pair.

## 1. INTRODUCTION

Transmissions made of polymeric materials play a very important role in the electrical engineering industry. Their use is justified due to the need to adjust the rotational speed, which is forced, in a way, by the characteristics of modern electric motors or the need to use various attachments requiring different speeds. Additionally, they are much cheaper in production than steel gears and often do not require a lubricant described in [1, 2].

Polymer gears can be found in most household appliances. Such gears are characterised by a variety of geometries. Practically, all types of gears are used, even in classical steel solutions. One of the new, untypical solutions of the tooth geometry is helical-bevel gears, hereinafter referred to as Beveloid gears (proprietary name). In relation to polymeric materials, the natural advantage of Beveloid gears is the occurrence of a rim narrowing angle of  $\delta$  and, consequently, a variable tooth thickness. These features make Beveloid gears much better suited for the removal from injection moulds. Obviously, Beveloid gears with a small cone angle and a comparably high helix angle would still retain a negative draft angle in the injection moulding process. Such relationships will be examined in subsequent articles.

The paper shows that selecting an appropriate  $\delta$  angle value according to the described methodology is possible to minimise the sound pressure level and amount of heat emitted during operation gears. The analytical method of determining the optimal angle, based on the FEM method, is described in item [3].

Beveloid gears are created by cutting a notch between the teeth on a truncated cone rotational surface using a fixed-width tool (Fig. 1). This tool is compatible with standard tools used in gear machining. This leads to a tooth geometry with variable thickness (Fig. 2). One of the features of such gears is that they have a geometry identical to helical gears with a straight tooth line in the central section of the rim (Fig. 3).

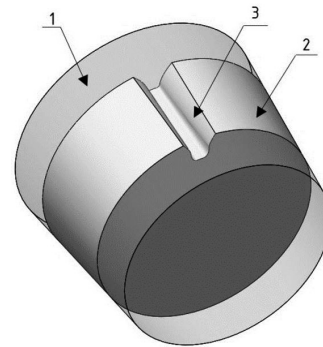

**Fig. 1.** The geometry of a Beveloid gear: 1 – the rotational surface of a truncated cone, 2 – gear rim, 3 – tooth notch

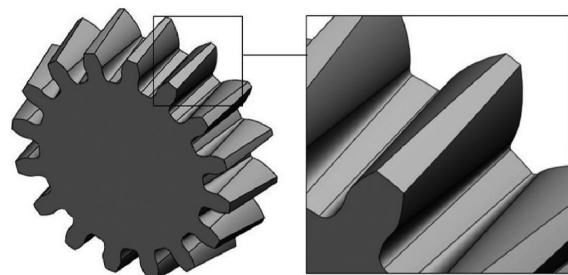

**Fig. 2.** Tooth shape in a Beveloid gear

\*e-mail: pstrojny@prz.edu.pl

Manuscript submitted 2021-03-02, revised 2021-07-26, initially accepted for publication 2021-08-22, published in October 2021

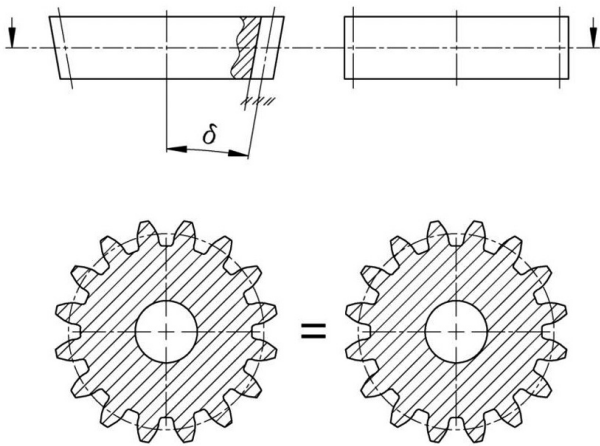

**Fig. 3.** The geometric relationship between a Beveloid gear and helical gear with a straight tooth line

One of the most important features of Beveloid gears is the occurrence of an additional axial force  $F_{ab}$  in the gearing, the value of which can be determined from dependencies (1)–(4) based on Fig. 4.

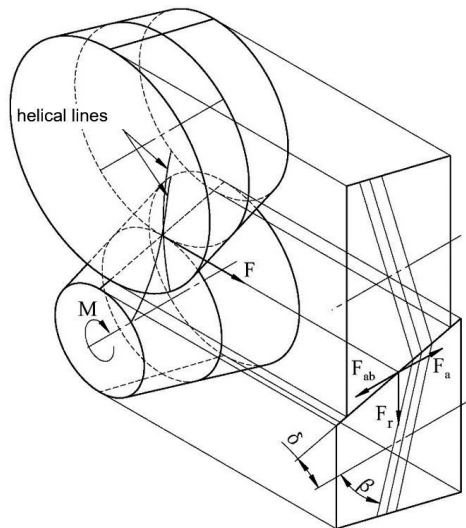

**Fig. 4.** Forces diagram in a Beveloid gear transmission with a helical tooth line

Equations to determine the values of forces in Beveloid gears with straight tooth lines:

$$F = \frac{M}{r}, \quad (1)$$

$$F_r = F \tan \alpha, \quad (2)$$

$$\tan \delta = \frac{F_r}{F_{ab}}, \quad (3)$$

$$F_{ab} = \frac{F_r}{\tan \delta}, \quad (4)$$

$$F_{ab} = F \frac{\tan \alpha}{\tan \delta}, \quad (5)$$

where:

$M$  – entry torque,

$r$  – pitch radius,

$F$  – circumferential force,

$\alpha$  – pressure angle,

$F_r$  – radial force,

$\delta$  – gear rim narrowing angle,

$F_{ab}$  – axial force.

The distribution of forces in Beveloid gear transmissions with helical tooth lines is presented in Fig. 4. This facilitates formulating the following relationships (6)–(11).

Equations to determine the values of forces in Beveloid gears with a helical tooth line:

$$F = \frac{M}{r}, \quad (6)$$

$$F_r = F \frac{\tan \alpha_n}{\cos \beta}, \quad (7)$$

$$F_a = F \tan \beta, \quad (8)$$

$$\tan \delta = \frac{F_r}{F_{ab}}, \quad (9)$$

$$F_{ab} = \frac{F_r}{\tan \delta}, \quad (10)$$

$$F_{ab} = F \frac{\tan \alpha_n}{\cos \beta \tan \delta}, \quad (11)$$

where:

$M$  – entry torque,

$r$  – pitch radius,

$F$  – circumferential force,

$\alpha_n$  – pressure angle in the normal section,

$F_r$  – radial force,

$F_a$  – axial force from tooth tilting angle,

$\delta$  – gear rim narrowing angle,

$\beta$  – tooth tilting angle,

$F_{ab}$  – axial force from a rim narrowing angle.

If the direction of the helical line is selected correctly, it is possible to compensate for the  $F_a$  force and  $F_{ab}$  force, as shown in equations (12)–(16). This is only possible under the assumption that the transmission will rotate in one direction.

Compensating for axial forces in Beveloid gear transmissions with helical tooth line:

$$F_a = F_{ab}, \quad (12)$$

$$F \tan \beta = F \frac{\tan \alpha_n}{\cos \beta \tan \delta}, \quad (13)$$

$$\tan \delta \tan \beta = \frac{\tan \alpha_n}{\cos \beta}, \quad (14)$$

$$\delta = \text{atan} \frac{\tan \alpha_n}{\cos \beta \tan \beta}, \quad (15)$$

$$\delta = \text{atan} \frac{\tan \alpha_n}{\sin \beta}. \quad (16)$$

The possibility of obtaining a small angle between the axes of mating gears is not insignificant, which increases the possibility of constructional application of Beveloid gear geometry.

Based on the analysed literature, it was found that there are no experimentally research-determined parameters of transmission operation, including the sound pressure level and the amount of heat emitted during the operation of a Beveloid gear.

The research results presented below refer to the possibility of using Beveloid gears made of polymer material in devices in the electromechanical sector. Two representative devices described in Section 6 were designed, made, and tested in accordance with the guidelines of the methodology below to verify its correctness.

## 2. STAND TESTS OF POLYMER TRANSMISSIONS WITH BEVELOID GEARS

The purpose of the study was to check how Beveloid transmissions behave in real working conditions, based on the construction of the stations described in [4–7]. The tests were carried out on a specially designed and constructed stand (Figs. 5–9) for this purpose. They stand together with additional accessories, the FLIR SC5000 [8] type thermal imaging camera and the VOLT CRAFT SL-50 type sound pressure level sensor allowed to check how the transmission heats up and what is the sound pressure level. The results made it possible to estimate how much the application of an appropriate angle  $\delta$  will affect the operation of the transmissions described.

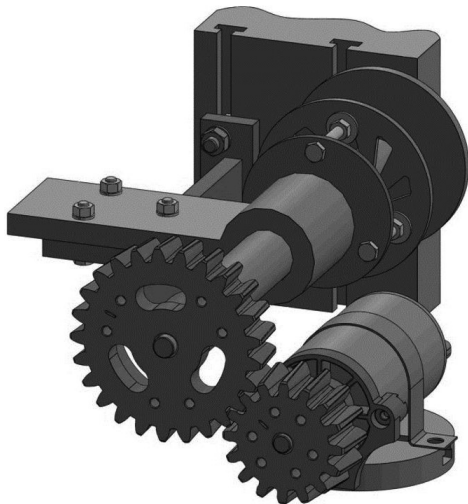

**Fig. 5.** CAD design of the Beveloid transmission test stand

The stand consists of an analogue speed controller {1} for controlling the electric motor {2} with a rated power of 0.25 kW and a rotation speed of 11000 rpm, a crane system {3} for adjusting the distance and the angle of inclination of axes between the cooperating gears. The stopping torque is provided by a disc brake {4}. A cover with an aluminium insert {5} protects the transmission from the influence of the temperature from the motor. The gears tested were locked to the motor and brake shafts by means of screws {6} and {7} (Fig. 9).

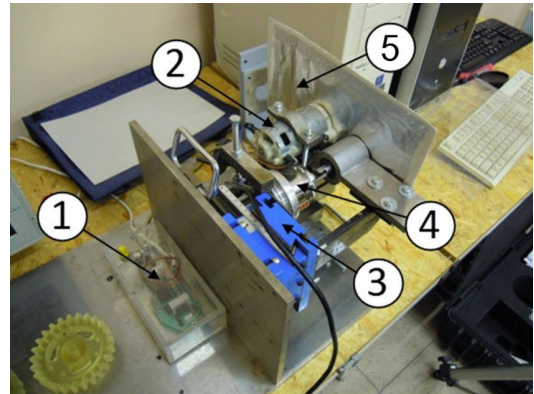

**Fig. 6.** Beveloid transmission test stand



**Fig. 7.** Complete test stand for testing transmissions with Beveloid gears



**Fig. 8.** FLIR SC5000 thermal imaging camera [8]

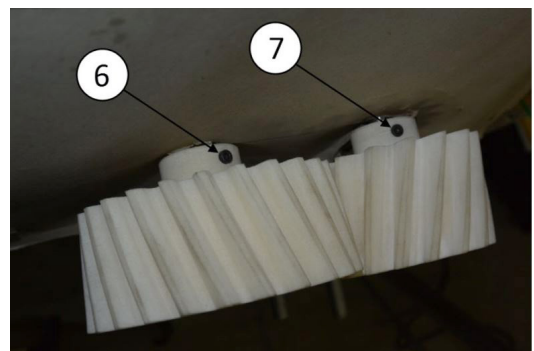

**Fig. 9.** Manner of locking gears on the motor pivot and brake shaft

**Table 1**  
Parameters of the transmissions tested

Ratio	Module	Number of pinion teeth	Number of gear teeth	Crest clearance	Circumference clearance	Pinion rim width	Gear rim width	Tooth line tilt angle	Beveloid gear narrowing angle						
$u$	$m$ [mm]	$z_1$	$z_2$	$c$ [mm]	$j$ [mm]	$b_1$ [mm]	$b_2$ [mm]	$\beta$ [°]	$\delta$ [°]						
Beveloid gear narrowing angle with a straight tooth line															
1.5625	4	16	25	1	0.3	50	47	0	0	1	2	3	4	5	
Transmission index: P.1									P.1.0	P.1.1	P.1.2	P.1.3	P.1.4	P.1.5	
1.6111	3	18	29	0.8	0.2	43	40	0	0	1	2	3	4	5	
Transmission index: P.2									P.2.0	P.2.1	P.2.2	P.2.3	P.2.4	P.2.5	
Beveloid gear with a helical tooth line															
1.5625	4	16	25	1	0.3	50	47	16	0	1	2	3	4	5	
Transmission index: P.4									P.4.0	P.4.1	P.4.2	P.4.3	P.4.4	P.4.5	
1.6111	3	18	29	0.8	0.2	43	40	14	0	1	2	3	4	5	
Transmission index: P.5									P.5.0	P.5.1	P.5.2	P.5.3	P.5.4	P.5.5	

### 3. THE TECHNOLOGY OF TEST MODEL MAKING

The physical models of previously modelled Beveloid gears were made using rapid prototyping (RP) techniques described in the literature [9–11]. A group of test models was made in SLS (Selective Laser Sintering) technology. The technology consists of producing parts by applying layers of powdered plastic and sintering them selectively by laser.

The SLS technology was chosen because it allowed making parts from materials with parameters similar to those used in the mass production of polymeric gears [12, 13]. Gears in SLS technology were made of polymer Derlin 500P NC010 (ISO 1043, ISO 11469), which corresponded to the group of polymers used in mass production of plastic gears (data from DuPont™ company) [14, 15].

48 Beveloid gears were made for testing in the SLS technology. The gears were assembled into 24 transmissions with different parameters.

A detailed breakdown and parameters of the gears used for testing are given in Table 1.

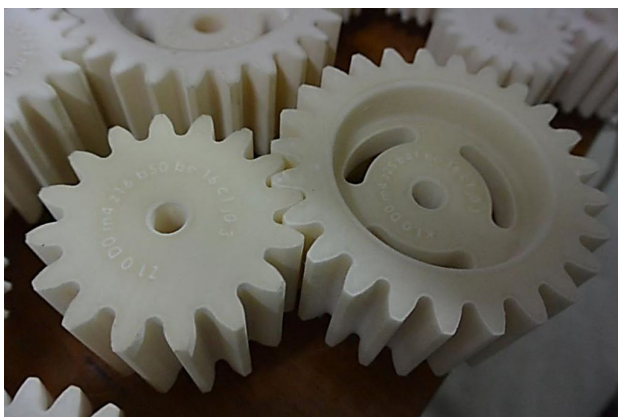

**Fig. 10.** Numbering to facilitate the correct combination of transmissions tested

Due to many models tested, the transmission faces were numbered to allow us for an unmistakable comparison of the tested gears (Fig. 10).

The models of SLS gears were made in the accuracy grade of typical mass-produced gears made of polymeric materials in dies. According to the manufacturer of the tested gears, after the measurements, the gears were in the 9th accuracy grade (IT09 – ISO 286-1). Gears produced in dies have often defects that did not occur with SLS technology, i.e., various types of deformations resulting from heterogeneous contraction, which is influenced by complex tooth geometry. However, modern die design techniques facilitate avoiding such faults.

### 4. THE MEASUREMENT AMOUNT OF THE HEAT EMITTED DURING THE GEAR OPERATION

After all the pairs of gears were manufactured using the SLS method, the temperature during transmission operation was measured. The research was carried out in accordance with the methodology described in [2, 16, 17]. The tests aimed to check how the  $\delta$  angle affects the amount of heat emitted during the gears mating. In order to limit the occurrence of measurement errors, each pair of mating gears was tested three times, and then the arithmetic mean of the obtained measurement results was calculated. Each transmission worked for exactly ten minutes [1].

The torque and rotational speed were constant over time for all measurements and were 0.216 [Nm] and 11000 [rpm], respectively. The ten-minute test time was dictated by the guidelines in the manual of household appliances that work periodically, and the maximum working time should not exceed ten minutes. The tests were carried out in an air-conditioned room at a constant temperature (20°C) and humidity (45%). The RTI Impact for the tested material according to UL 746B is 85C. The relative temperature index (RTI) is a characteristic parameter related to the thermal degradation of plastic materials. Dur-

ing the process of the UL 746B program, the degradation of certain properties of the material, like dielectric and mechanic strength, is investigated regarding thermal ageing. The RTI is the temperature in °C, at which the properties have decreased to 50% of their initial value after a long-term exposure to this temperature. The highest temperature during the tests of the described gears was 41.3°C.

The number of tested objects allowed us to conduct 72 measurements. The ALTAIR software version 5.90.001 dedicated for FLIR SC5000 type thermal imaging camera allowed us for the precise reading of the average temperature value on the side surface of a gear tooth (Fig. 11) [8].

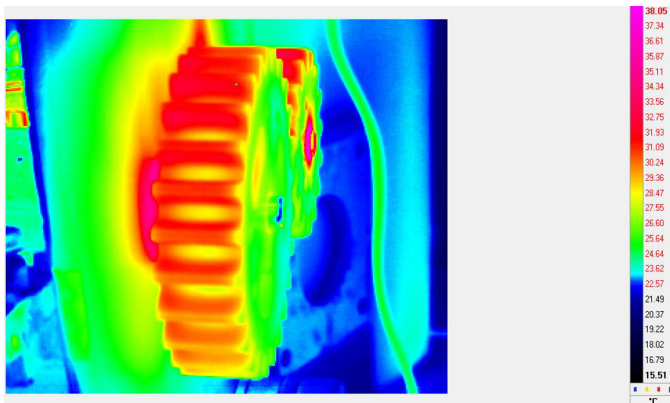

Fig. 11. Temperature distribution on the side surface of the tooth

The last step of the heat emission test was a graphical presentation of the obtained results. Figures 12–15 present the change in temperature at the gear side surface for different  $\delta$  angles in the four transmission groups tested.

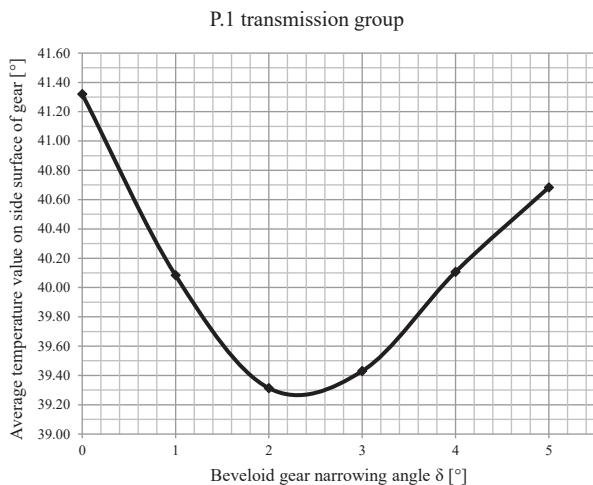

Fig. 12. Average temperature value on the side surface of the gear for the analysed group of gears with variable  $\delta$  angle (according to Table 1)

Figures 16–19 show how the value of the average measured temperature on the side surface of gear changed for subsequent measurements (measurements 1, 2, 3) carried out in given gear groups (P1, P2, P4, P5).

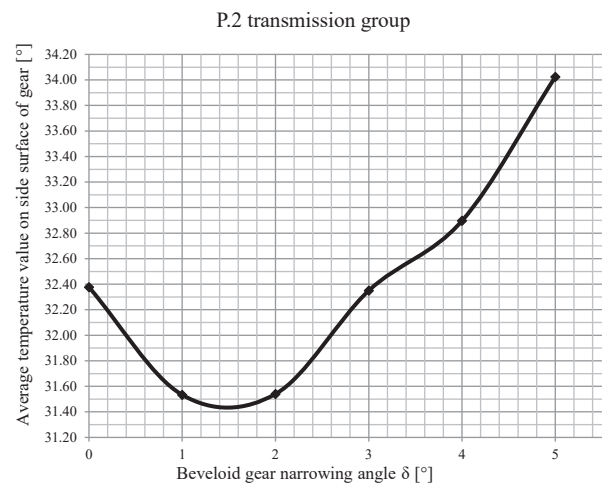

Fig. 13. Average temperature value on the side surface of the gear for the analysed group of gears with a variable  $\delta$  angle (according to Table 1)

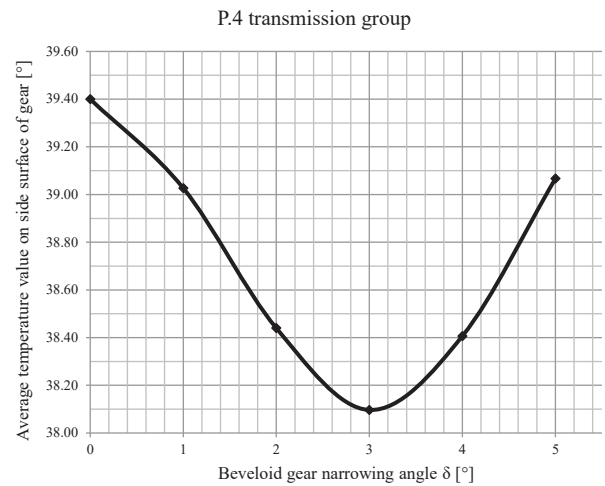

Fig. 14. Average temperature value on the side surface of the gear for the analysed group of gears with a variable  $\delta$  angle (according to Table 1)

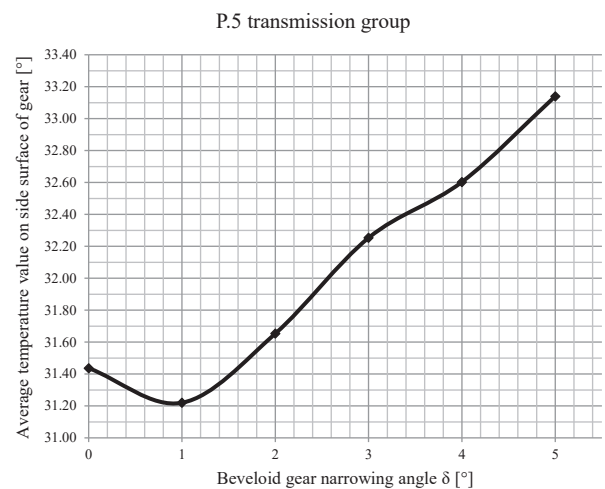
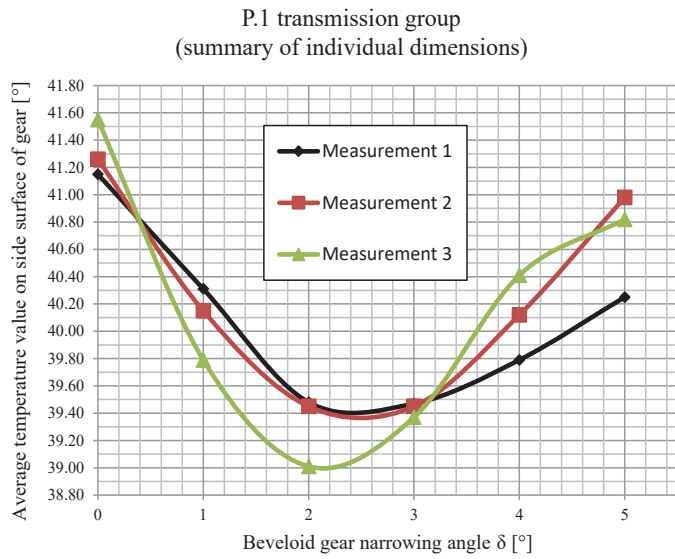
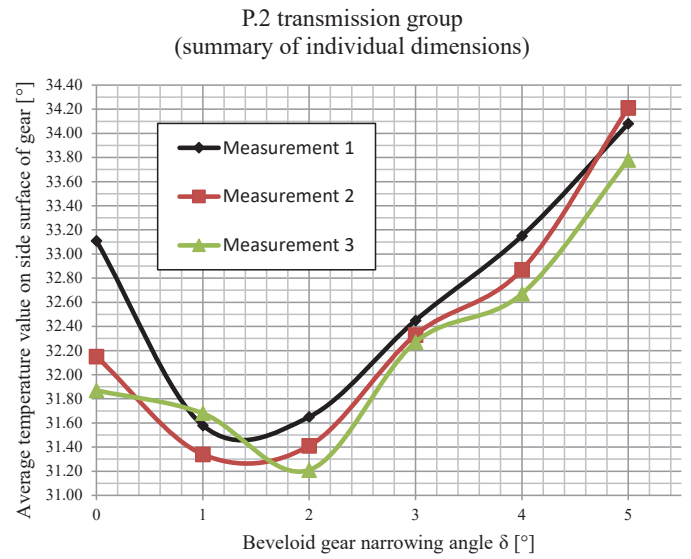

Fig. 15. Average temperature value on the side surface of the gear for the analysed group of gears with a variable  $\delta$  angle (according to Table 1)



**Fig. 16.** Three measurement series of the average temperature value on the side surface of the gear for the analysed group of transmission with a variable  $\delta$  angle (according to Table 1)



**Fig. 17.** Three measurement series of the average temperature value on the side surface of the gear for the analysed group of transmission with a variable  $\delta$  angle (according to Table 1)

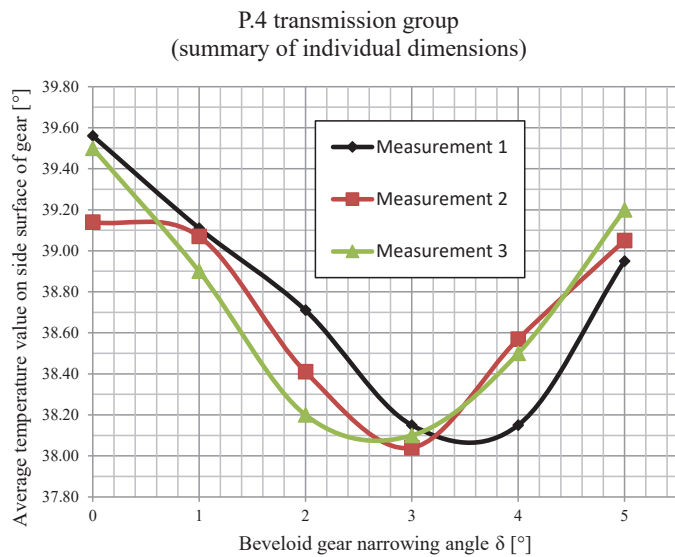

**Fig. 18.** Three measurement series of the average temperature value on the side surface of the gear for the analysed group of transmission with a variable  $\delta$  angle (according to Table 1)

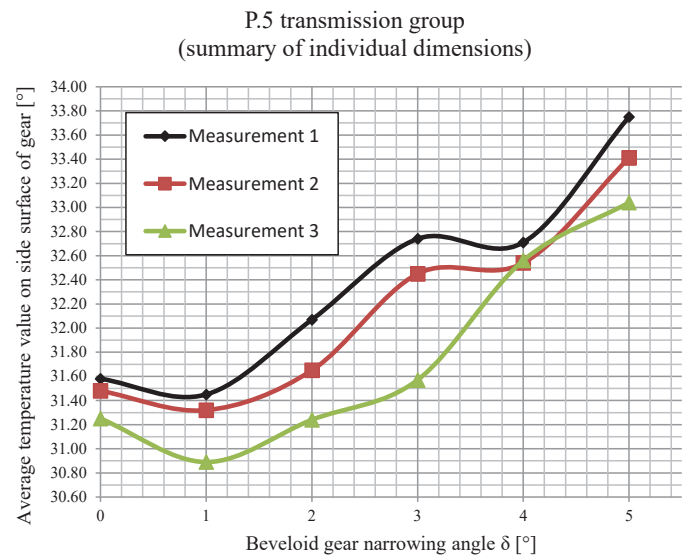

**Fig. 19.** Three measurement series of the average temperature value on the side surface of the gear for the analysed group of transmission with a variable  $\delta$  angle (according to Table 1)

## 5. THE SOUND PRESSURE LEVEL MEASUREMENT

Due to the high importance of the sound pressure level during a transmission operation in electro-machinery equipment (mainly household appliances), an attempt was made to estimate the influence of  $\delta$  angle on its level during the transmission operation. The above-mentioned methodology is described in [17, 18].

Measurements of the sound pressure levels were made simultaneously with temperature measurements. Similar to temperature measurement, the sound pressure level was measured three times for each transmission, and then the arithmetic mean of the measurement results was calculated. Each time during 10 minutes of transmission operation, the sound pressure level was

measured at the 3rd, 5th, and 9th minute of transmission operation, and then the arithmetic mean of the obtained measurement results was calculated. The number of tested objects allowed us for 216 measurements.

The last step of the sound pressure level test was a graphical representation of the obtained measurement results. The graphs in Figs. 20–23 show how the sound pressure level in transmissions changes for different  $\delta$  angles.

The diagrams in Figs. 24–27 show how the average sound pressure level changed for subsequent measurements (measurements 1, 2, 3) carried out in given transmission groups (P1, P2, P4, P5).

Impact of gear rim narrowing angle on the temperature and sound pressure of Beveloid gear pair made of polymeric materials

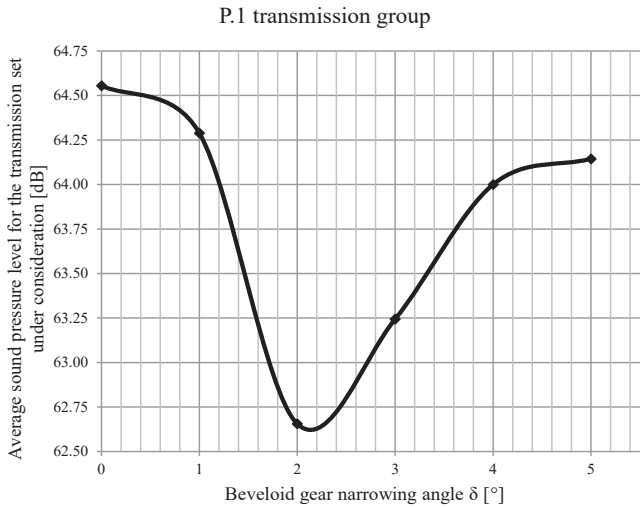

**Fig. 20.** The value of the average sound pressure level for the analysed group of transmissions with a variable  $\delta$  angle (according to Table 1)

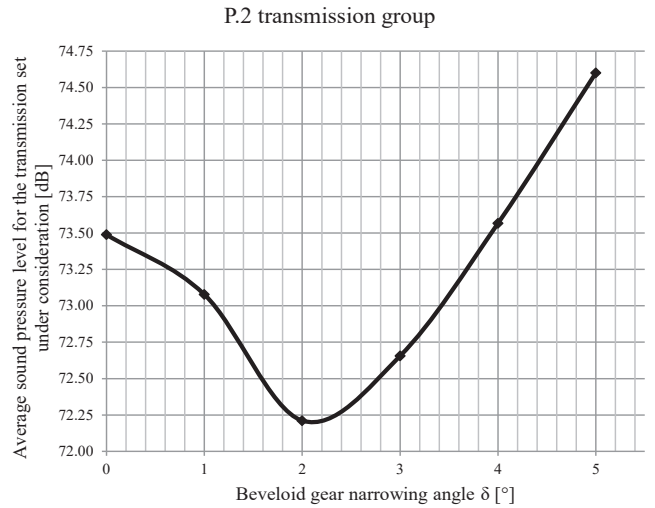

**Fig. 21.** The value of the average sound pressure level for the analysed group of transmissions with a variable  $\delta$  angle (according to Table 1)

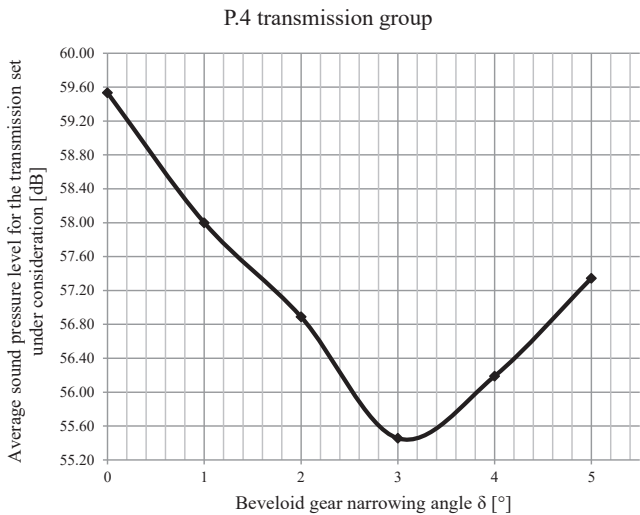

**Fig. 22.** The value of the average sound pressure level for the analysed group of transmissions with a variable  $\delta$  angle (according to Table 1)

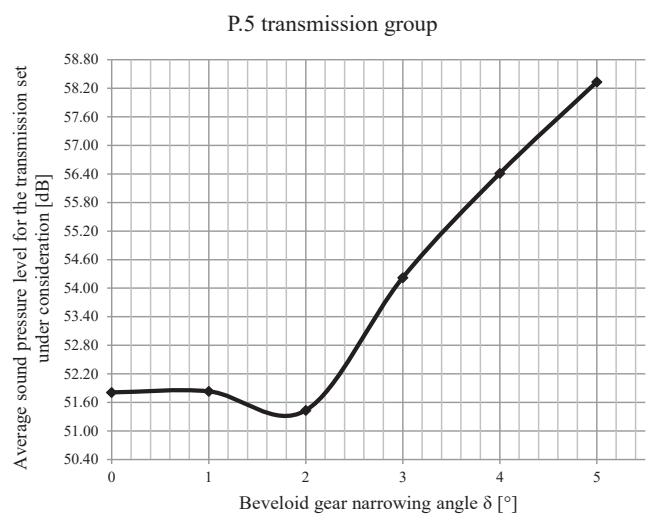

**Fig. 23.** The value of the average sound pressure level for the analysed group of transmissions with a variable  $\delta$  angle (according to Table 1)

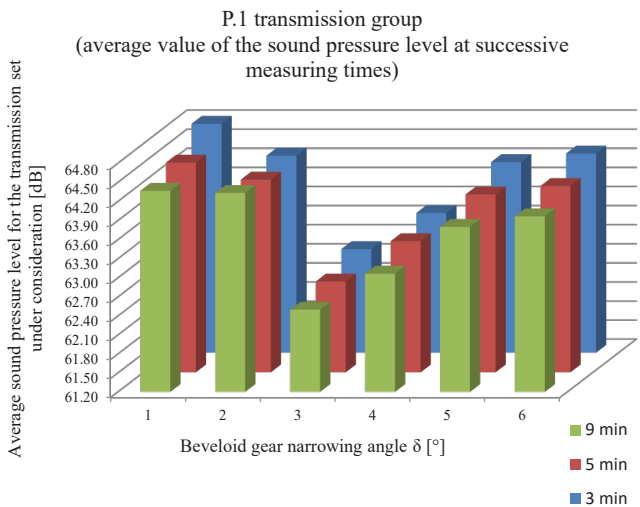

**Fig. 24.** The average value of the sound pressure level for subsequent measurements carried out in given transmission groups (according to Table 1)

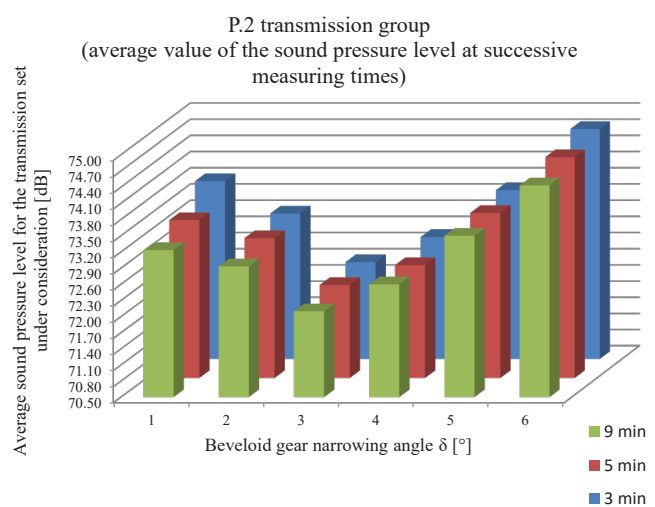

**Fig. 25.** The average value of the sound pressure level for subsequent measurements carried out in given transmission groups (according to Table 1)

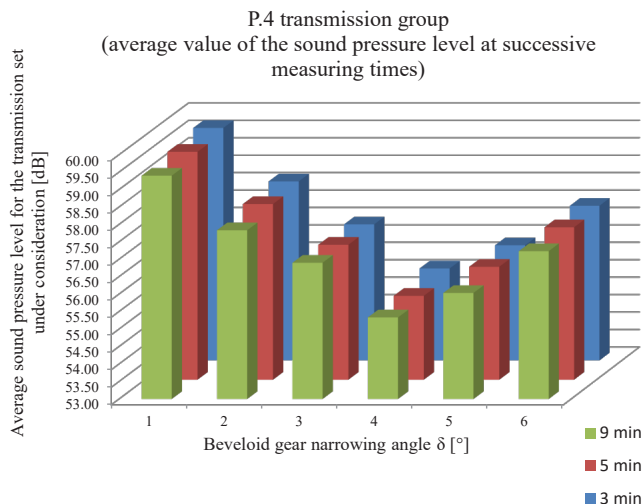

**Fig. 26.** The average value of the sound pressure level for subsequent measurements carried out in given transmission groups (according to Table 1)

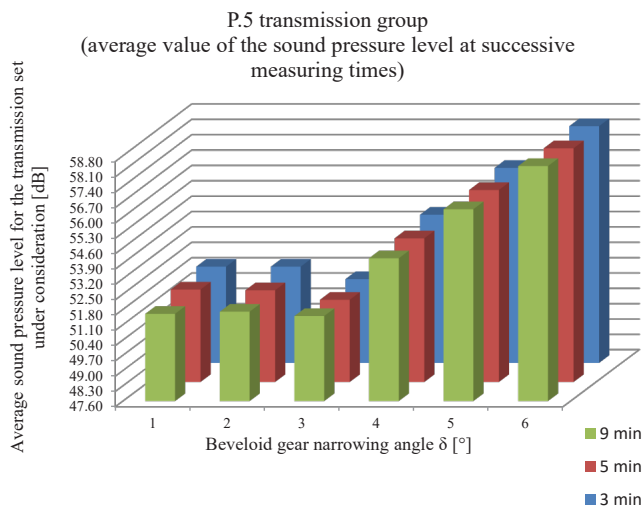

**Fig. 27.** The average value of the sound pressure level for subsequent measurements carried out in given transmission groups (according to Table 1)

## 6. OPERATIONAL TESTS OF HOUSEHOLD APPLIANCES WITH BEVELOID GEARS

Using the method described in the paper for the selection of  $\delta$  angle, two devices from the electromechanical sector were designed and manufactured: a grinder (Fig. 28) and a jam mixer (Fig. 29).

These devices were subjected to the same loads as those in commercial solutions. According to the instructions for use, the working time under load for the grinder is  $10 \div 15$  minutes and  $20 \div 30$  minutes for the mixer.

First, the grinder was tested in which helical gears with a helical tooth line were used on the first stage of the (planetary) gear. The device was cyclically switched on for 15 minutes and off, leaving it to cool down for a total of 30 minutes. This cycle was repeated until the transmission was damaged. The transmission in the machine was damaged after 223 cycles. There

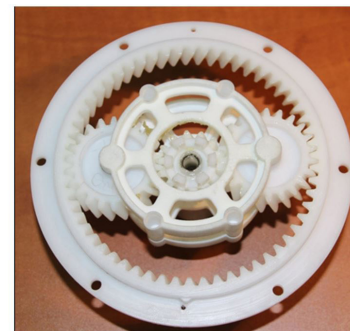
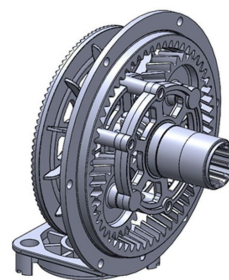

**Fig. 28.** Grinder transmission units: on the right, CAD model of a grinder; on the left, an actual model of the second gear of grinder transmission

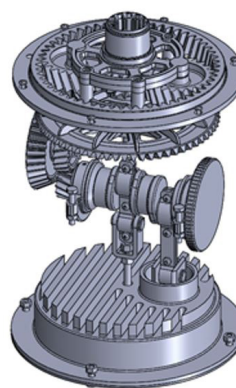

**Fig. 29.** Jam mixer: on the right, CAD model of a mixer; on the left, actual mixer model

was a tooth breakage on the central gear. In addition, after the 185th cycle, the sound pressure level in the device increased noticeably. Then, identical tests were started on the device after replacing the helical gears with Beveloid gears with a helical tooth line on the transmission first gear. As in the previous test, the central gear was damaged. The damage occurred after 267 cycles, and an increase in the sound pressure level was noticed after 239 cycles.

The operational tests of the mixer were conducted in the same way. The device was started up for 30 minutes and then left to cool down for 60 minutes. This cycle was repeated until the transmission was damaged. The transmission in the mixer was damaged after 191 cycles. As in the grinder, a tooth on the central gear was broken. In addition, after the 168th cycle, the sound pressure level in the device increased noticeably. Then, the tests were started on the device after replacing the helical gears with Beveloid gears with a helical tooth line on the transmission first gear. The damage to the central gear occurred after 217 cycles, and an increase in the sound pressure level was noticed after 202 cycles.

A relatively small number of work cycles obtained before the destruction of the gear in the above-mentioned devices may re-



sult from the fact that the tested devices were prototypes. They did not have the same degree of technological refinement as the series-produced devices. Nevertheless, the obtained number of cycles with the assumed unit operating time (10÷15 minutes and 20÷30 minutes) allows the above-mentioned devices to work for about 100 hours. Devices of this type work periodically, and the obtained number of cycles gives the possibility of many years of operation.

## 7. DISCUSSION ABOUT THE RESULTS

After testing the amount of heat emitted during the mating of transmissions with Beveloid gears, it can be concluded that the  $\delta$  angle influences the transmission heating during operation. Four groups of transmissions (P1, P2 transmissions with straight tooth lines and P4, P5 transmissions with helical tooth lines) were analysed. The tests carried out have shown that in the transmission groups tested, the  $\delta$  angle influences the amount of heat emitted in the transmission. In the first two groups of transmissions P1, P2 (Figs. 12, 13), it can be clearly seen that at angles  $\delta$  from  $1^\circ$  to  $3^\circ$ , there is a decrease in the heating of the transmission, while at extreme values of the  $\delta$  angle, the measured temperatures are higher. Similar results were obtained in groups of transmissions with a P4, P5 (Figs. 14, 15) helical tooth line; the lowest temperatures of heating of the side surfaces of the tooth were noted at  $\delta$  angles from  $1^\circ$  to  $3^\circ$ . A certain analogy of test results was noted in the size of the test models. Transmissions from groups P1, P4 were almost twice as big as those from groups P2, P5, which could cause differences in the trends in profiles visible in the graphs. Due to the use of 3D printing technology (SLS), characterised by a constant value of accuracy regardless of the size of the model (constant error related to resolution and accuracy of the apparatus), larger models (groups P1, P4) had absolute geometry errors just like the smaller models, so it can be considered that their relative manufacturing accuracy was greater than for groups P2, P5. Therefore, it can be assumed that the results of studies carried out on models of groups P1, P4 are more reliable than those of groups P2, P5.

The list of all measurements (measurements 1, 2, 3) in given transmission groups (Figs. 16–19) additionally shows how the heat build-up of the side surfaces of the gear tooth decreases with the running-in of the transmission. Figures 16–19 show how the trends decrease in subsequent measurements. This suggests that the last measurement carried out after the initial running-in of the transmission most closely reflects the reliability of the results.

After the sound pressure level in the analysed transmissions was tested, it can be unequivocally stated that similarly to transmission heating, the narrowing angle of a Beveloid transmission impacts the sound pressure level in polymeric transmissions. The results of the sound pressure level measurements shown in Figs. 20–23 show how the sound pressure level changes with an increase in  $\delta$  angle. The lowest sound pressure level is at  $\delta$  angles from  $1^\circ$  to  $3^\circ$ . In addition, the shape of the obtained trends is comparable to the shape of the trends obtained during the transmission heating tests. This shows that

the  $\delta$  angle affects both the heating of the transmission and the sound pressure level according to similar characteristics.

The sound pressure level results are shown in Figs. 24–27 for the individual minutes of measurement (3, 5, 9th minutes) and display an insignificant reduction in the sound pressure level of the transmission operation with time. As with transmission heating, this may be caused by the transmission running in during operation.

The operation tests for household appliances described in Section 6 confirm the previous results of tests carried out directly on transmissions. During intense service, the service life of a Beveloid gear grinder has proven to be 16% longer than its equivalent with helical gears with helical tooth lines. In the case of the mixer, the difference was 12% in favour of Beveloid gears.

## 8. SUMMARY

Many variable parameters in the design of the transmission do not facilitate the unambiguous indication of the  $\delta$  narrowing angle at which polymeric transmissions would have the best operating conditions. To select an appropriate  $\delta$  angle, several transmissions with identical parameters differing only in  $\delta$  angle must be analysed each time.

The results of operational tests on household appliances show that by using Beveloid gears we can increase the life of such appliances by about 14%. That results from the previously conducted heating and sound pressure level tests. A lower sound pressure level is due to the higher uniformity of the transmission operation, leading to a lower temperature. The whole contributes to a longer service life of the transmissions, which are the most critical point of most equipment in the electromachinery sector.

## REFERENCES

- [1] S. Beermann, "Estimation of lifetime for plastic gears," *Fall Technical Meeting of the American Gear Manufacturers Association*, Detroit, Michigan, Oct. 2007, pp. 1–17.
- [2] R. Keresztes, L. Zsidai, G. Kalácska, and P. De Baets, "Friction of polymer/steel gear pairs," *Scientific Bulletin of North University of Baia Mare*, serie C, vol. XXIII, pp. 63–72, Jan. 2009.
- [3] P. Strojny, "Wpływ kąta zwężenia kół zębatych typu Beveloid na płynność przeniesienia napędu w przekładniach zębatych z tworzyw polimerowych," *Przegląd Mechaniczny*, no. 6, Jun. 2016, [in Polish].
- [4] N. Agbetossou, A. Afio, K. Attipou, D. Koffi, K. Kassegne, and S. Tiem, "Modeling and Prediction of Wear for Gears in Plastic Materials and Their Composites," *Int. J. Eng. Res. Technol.*, vol. 9, no. 7, pp. 90–106, Jul. 2020.
- [5] A.J. Muminovic, M. Colic, E. Mesic, and I. Saric, "Innovative design of spur gear tooth with infill structure," *Bull. Pol. Acad. Sci. Tech. Sci.*, vol. 68, no. 3, pp. 477–483, 2020.
- [6] N.B. Thamba *et al.*, "Study of Effect of Linear Tip Relief Modification in Power Transmission Efficiency of Spur Gears," *Arch. Acoust.*, vol. 45, no. 2, pp. 271–282, 2020.
- [7] G. Yu, H. Liu, K. Mao, C. Zhy and Z. Lu, "Examination on the wear process of polyformaldehyde gears under dry and lubricated conditions," *Friction*, vol. 9, pp. 538–550, Jan. 2020.
- [8] Flir, [Online]. Available: [www.flir.com](http://www.flir.com) (accessed Feb. 12, 2021).

- [9] A. Gebhardt, *Rapid Prototyping*, Carl Hanser Verlag GmbH & Co. KG, Munich, 2003.
- [10] W.F. Liu, *Rapid Prototyping and engineering applications – a toolbox for prototype development*, Taylor & Francis Group, Boca Raton, USA, 2008.
- [11] R.E. Śliwa, G. Budzik, J. Bernaczek, and T. Dziubek, “The rapid Prototyping of aircraft wheel hub model with the use of techniques JS, SLA, FDM,” *J. KONES Powertrain Transp.*, vol. 18, pp. 439–443, Mar. 2011.
- [12] T. Singh, S. Kumar, and S. Sehgal, “3D printing of engineering materials: A state of the art review,” *Mater. Today Proc.*, vol. 28, no. 3, pp. 1927–1931, 2020.
- [13] N.B. Thamba *et al.*, “Fault Analysis of Worm Gear Box Using Symlets Wavelet,” *Arch. Acoust.*, vol 45, no. 3, pp. 521–540, 2020.
- [14] A. Hamrol, J. Gawlik, and J. Śladek, “Mechanical engineering in Industry 4.0,” *Manag. Prod. Eng. Rev.*, vol. 10, pp. 14–28, Sep. 2019.
- [15] Dupont. [Online]. Available: [www.dupont.com](http://www.dupont.com) (accessed Feb. 10, 2021).
- [16] J.F. Rabek, “Współczesna wiedza o polimerach,” *Tom 1. Budowa strukturalna polimerów i metody badawcze*, PWN, Warszawa, 2017 [in Polish].
- [17] M. Sobolak and P. Strojny, “Effect of the narrowing angle in beveloid gear on the temperature profile on the active flank of tooth,” *Adv. Sci. Technol. Res. J.*, vol. 7, pp. 67–69, Dec. 2013.
- [18] M. Płocica and A. Marciniec, *Methodology of Preparing Hypoid Gears for Vibroacoustic Diagnostics in Laboratory Conditions*, Oficyna Wydawnicza Politechniki Warszawskiej, Warszawa, 2018.