

Utilisation of Production Knowledge in Developing a Modern Customer-Oriented Project Business Environment

Jyri VUORELA¹, Mikael OLLIKAINEN¹, Vesa SALMINEN², Juha VARIS¹

¹ Energy Systems, LUT University, Finland

² Smart Research Center, Häme University of Applied Sciences, Finland

Received: 15 November 2021

Accepted: 17 August 2022

Abstract

History has shown different approaches to improving productivity the way of companies do business. Since the early 1900s, the development of different production systems has played an increasingly remarkable role in global manufacturing countries. It seems, that the growth of understanding has widened the ideology of production systems used up to current ones. This article examines the development path of business development. It evaluates the suitability of the key tools used to support change in a modern business model in a customer-driven project business environment.

Keywords

Business model, Project business environment co-evolution, Measuring system, Customer-oriented project business environment, Measuring change in business structures.

Introduction

Different models of improving business productivity and profitability have been used throughout history. Although the business models and segments differ by era, successful key factors can be found in developing productivity. A critical point on the road to evolving business success is undoubtedly continuous improvement. Since the development steps are not always going the right way in view of the whole system, it is essential to understand each development factor's meaning and its effects on the entire system.

In the development path of operative business efficiency, the key role is to separate steps forward and those that should be re-evaluated. Measuring the change and development of business structures and elements is at the centre of progress. This article's scientific proposition is that business transition requires a co-operatively defined measuring system. This reveals the following research question: How to measure the change and development of business structures and elements? The role of different business sectors

affects measuring dilemmas in a significant way. The perspective is viewing differently if you are operating with services, groceries, daily appliances, cars or large machine project deliveries.

This article aims to create a modern operating model in a customer-driven project business environment based on knowledge of different manufacturing ideologies starting from early mass production to modern 21st-century agile manufacturing. The target is to take account of customer expectations and quality requirements while still creating cost-effective standard and customer-specific products in a modern global networked operating environment.

Literature review

Many years of studies, innovations, implementations, corrections and readjustments have evolved the approach of efficient working models. The essence of business or production models, which was stated brilliantly almost three decades ago, can be described as eliminating waste. In the 'big picture', waste exists in different forms, such as concrete and abstractive in company business models. The employees, their learning and continuous improvement culture have been at the centre of these ideologies. In this literature review, the main focus has been on the car manufacturing industry.

Corresponding author: Jyri Vuorela – LUT University, Yliopistonkatu 34, Lappeenranta, Finland, 53850, phone: (+358) 294 462 111, e-mail: jyri.vuorela@gmail.com

© 2022 The Author(s). This is an open access article under the CC BY license (<http://creativecommons.org/licenses/by/4.0/>)

Development path and history

In the early 1900s, many manufacturers like Morris, Austin, Renault, Citroen, Fiat, Opel and Volkswagen adopted Ford's production methods (Wilkins & Hill, 2011).

Ford's first car was road tested on June 4, 1896, which was the beginning of the new era. After Henry Ford finished working on it and had learned plenty from it, the car was sold. This was the first used car sale made in the U.S. Ford finished building his second car by 1898, which improved from the first (Curcio, 2013).

After the Model T's huge success, Ford and his employees started experimenting with assembly line production in 1908. The very first line was improvised, and rope operated. It is noted that earlier in history, pyramids were produced, and ship hulls were equipped in the 15th century using an assembly line method. Ford production's first assembly line was the flywheel magneto's subassembly in 1913. During one year, the line efficiency was improved from 20 minutes to 5 minutes, and workers decreased from 29 to 14 (Curcio, 2013).

Typical Ford mass production features used at that time were interchangeable parts, an in-house press process and a moving assembly line. At the same time, production models in high-volume manufacturing (mass production) can be found in segments other than the automotive industry, like guns, clocks, sewing machines, wagons, grain harvesters and bicycles (Hounshell, 1985).

Ford was an example of the successful mass production of cars and willingly or unwillingly shared production knowledge. Their production of cars and trucks in U.S. plants in 1903 was 1,708 vehicles. In Canada, for the year 1905, 117 vehicles. The existence of different Ford production facilities located in Europe began in the year 1912. It started in England, where they produced 3,178 cars, while in U.S. plants, they produced 170,068 cars and in Canada, 11,584 cars. In 1931 production began in Germany, and after a few years, in 1935, new production started in France. The number of cars and trucks produced in 1935 was quite significant. In the U.S. they assembled 1,120,606; in England 66,605; in France 9,692; in Germany 12,768 and in Canada 80,172 vehicles (Wilkins & Hill, 2011).

Ford had its own rubber plantation in the Amazon to ensure the availability of rubber for tyre production, which the company sold to the Brazilian government in 1945. Ford was even urged to participate in developing the Chinese economy by Sun Yat-sen in 1924 (Wilkins & Hill, 2011).

One of the pioneers of automation and flow production, Frank Woollard, was educated and graduated from the City of London School and Brick College. After college, he took an apprenticeship with the London and South Western Railway. There he gained practical knowledge of flow production. Woollard was also involved in the development of the Clarkson steam-powered omnibus. After getting more experience in car design as a leading draughtsman (Weigel Motors), in 1910, he became chief draughtsman. In 1918 he got promoted to chief engineer and assistant managing director. Woollard experimented with flow production during wartime to manufacture axles and gearboxes. As the general manager of Morris Motor's Engines Branch, he pioneered flow production and automation production during the 1920s. From 1924–1925, Woollard published several papers presenting the details of Morris Motor's flow production methods (Emiliani & Seymour, 2011).

In 1925 in his theory of continuous flow production, Woollard described that the target was not mass production; instead, it was an endeavour to secure continuous flow 'so that a relatively small factory may meet the greater overseas plants'. Mass production should be outdated by continuous flow production. Continuous production is not a new invention itself. Different industries (food, newspaper, textile and others) have been practising it for many years (Woollard, 1954).

Taiichi Ohno, the famous father of the Toyota production system and founder of the Lean ideology, was first requested to prepare standard work methods for textile work in the late 1930s. Since then, the map of proper working procedures has shown its importance in production. The standard worksheet should clearly list these three elements: Cycle Time (Takt), Work Sequence and Standard Inventory. Later it proved to be the origin of his plant-first principle (Ohno, 1988).

The improvement should not never end, Ohno claimed in the TPS system. The simple essential continuous improvement area to look should be the timeline from the moment customer places the order to the point the cash is collected. Improvements are to focus on reducing the timeline by removing the non-value-added wastes (Ohno, 1988).

One of the early founders of the Lean ideology and productivity consultant, Shigeo Shingō, has dramatically influenced different businesses' productivity. The first record of work on flow production was when he implemented it in 1943 at Amano Manufacturing for torpedo mechanisms and reached a 100% improvement in productivity. Between 1948 and 1954, he held production technology courses in different Japanese companies. In 1945 after giving courses at Toyota, he was hired as their first consultant. He widely taught

improvement training at Toyota and to their suppliers' employees (Shingö & Liker, 2007).

Shingö describes how the basics of production are the absolute elimination of waste by improving the four elements of process; processing, transport, inspection and delay. Processing is the only value-adding one; the remaining three are non-value-adding waste. These three should be eliminated as much as possible (Shingö, 1988).

Shingö later studied the Volvo method in the 1960s and visited Volvo plants several times. He noted that Volvo understands the human aspect of work differently. The Volvo method tolerated both worker types, the ones who are lazy by nature (type X) and those who are hardworking (type Y). Changing a characteristic of human nature from X to Y cannot be done quickly. The Volvo production system tolerated inventory because inventory is a necessary evil (Shingö, 1988).

Socio-technical Systems Theory was used at Volvo Cars to attempt to break Taylorism in their Kalmar and Uddevalla factories. They combined efficiency and workers' well-being. It became visible that a superior overall system needs the systems' most suitable elements from Lean Production (LP) and Socio-technical Systems Theory (STS) as a hybrid model. The workers' well-being has been in focus throughout the history of STS. By considering the work organisation's design, workers' natural motivation can be increased. 'Integrated work organisation' where production teams can master a diverse range of tasks following STS multifunctionality principles. Tasks are connected to production flow and previous indirect functions such as quality, control, maintenance and planning. Implementing lean practices and integrated work organisation together can achieve better productivity than solely implementing a lean production model. In the early stages of STS, responsible autonomy was a goal, which generated inventory buffers to protect production. Using integrated work organisations with key lean methods such as inventory reduction, just in time and a pull system instead of push brings positive benefits (Dabhikar & Lhlström, 2013).

Volvo business units have the freedom to choose whether or not to implement VPS, a continuum of Volvo's decentralised historical strategy. The main goal seen in Volvo's system is to create a learning organisation which has a greater change-takt time than its competitors. In global industries, the company-specific production systems' XPS growth and importance are indisputable (Netland & Aspelund, 2013).

World Class Manufacturing is another productivity and efficiency approach originally presented by Hays and Wheelwright in 1984. Schonberger later reinter-

preted this ideology and, in 1986, presented a new model of World Class Manufacturing (WCM). Fiat officially introduced its WCM model in 2006. One of the famous books on lean production is *The Machine that Changed the World* (Womack et al., 1990). Similarly, for WCM, there is the book: *World Class Manufacturing – The lessons of Simplicity Applied by Schonberger* (Chiarini & Vagnoni, 2015).

Agile manufacturing (AM) is a 21st-century approach to the manufacturing efficiency model. Different industry eras and production models can be identified, from the craft industry to mass production into lean and agile manufacturing. The agile concept is a flexible and quick response focused on the customer and customer-designed products. New tools provided by information technology, such as concurrent engineering, virtual manufacturing and information infrastructure, are deployed in agile manufacturing (Gunasekaran, 2001).

The term *agile manufacturing concept* was coined in 1991 by a team of researchers at Lehigh University's Iacocca Institute. Agile manufacturing models do not negate earlier manufacturing paradigms; and are more likely to synthesise from there to create a new 21st-century approach (Yusuf et al., 1999).

Method

This article is based on literature studies of different production models and novel proof-of-concept case studies made in real international business environments. The conceptual model for case-specific project business segments has been tested, measured, and developed over several years of study with daily business life. At the same time, valuable inputs from different organisational levels were also collected and implemented into an operative business model.

Results

Similar main tools were identified from many papers for model development and new ones created in the development process. Womack, Jones, and Liker clearly instructed the development process steps as follows, which were the study's guidelines.

After studying 50 companies and their lean processes, Womack and Jones (1996) ended up identifying five useful steps that lean companies have taken:

1. Define value precisely from the end customer's perspective regarding a specific product with specific capabilities offered at a specific price and time.

2. Identify each product or family's entire value stream and eliminate waste.
3. Make the remaining value-creating steps flow.
4. Design and provide what the customer wants only when the customer wants it.
5. Pursue perfection.

The method of developing organisational processes and flow of work suggested by Liker (2004) has recognised during the study (Fig. 1).

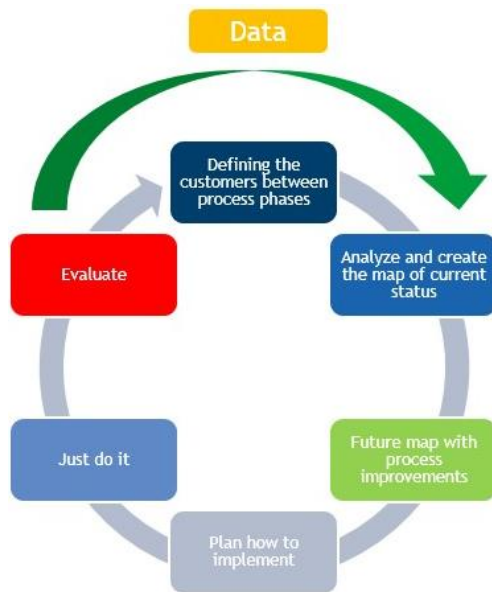

Fig. 1. Development model

1. Identify different customers (internal and external) in the process.
2. Recognise and understand both repetitive and unique processes.
3. Map the flow to define value-added and non-value-added issues.
4. Create a future-state value stream map with process improvements according to lean tools.
5. Implement improvements and use the PDCA (Plan-Do-Check-Act) cycle to continue development.

Applying previously described development processes in a case study result in a new operative production model named 'Delivery of new production capacity', which is called more descriptive in the 'big picture' (Fig. 2). It reveals the whole operational process with sub-processes. The 'delivery of new production capacity' covers the timeline from the customer quotation phase ending with the product warranty to the customer end. The work done so far is significant, and development and optimisation are continuing. The revision number of the 'big picture' is currently 25. It has several sub-processes inside the main process map. Several workshops are usually needed to cover the next step in the new revision of the process map.

Current state analysis

First, it is necessary to identify different customers influencing the process. Both internal and external

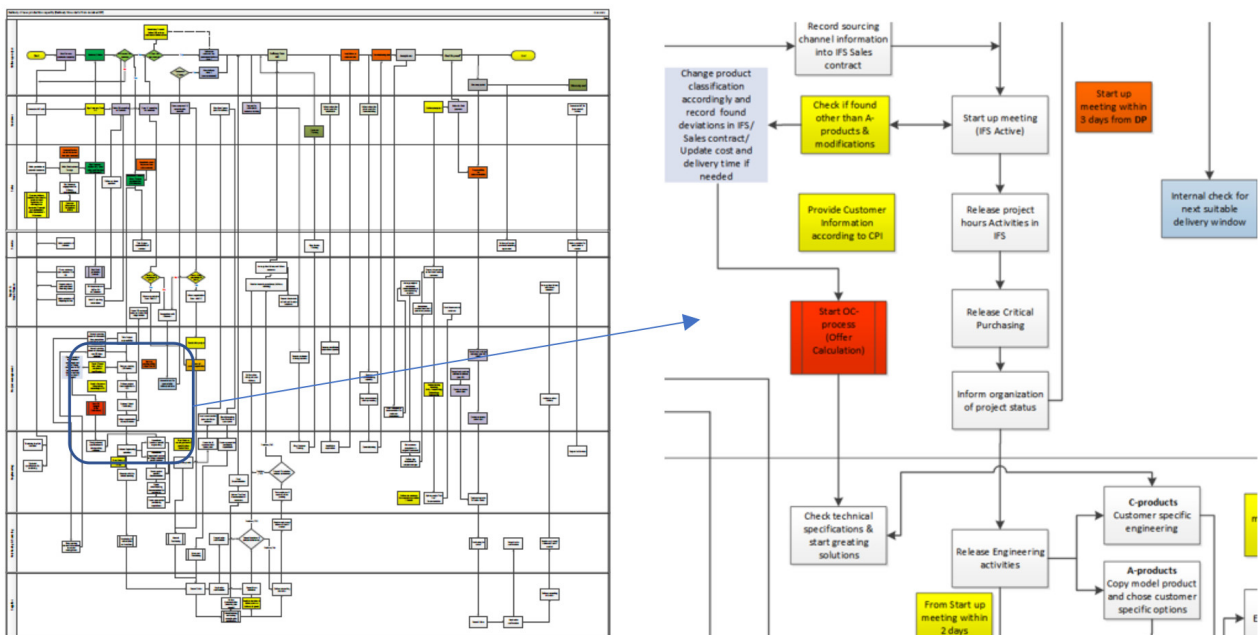

Fig. 2. Overall view of the "big picture and partial magnification from it"

operators were identified and marked in the table. Since the company business model operates with an outsourced model, the same resource can be marked internal and external (Table 1). Each identified operator got its own swim line in the ‘big picture’. The current state analysis was done with the swim line owner and lower and upper swim line representatives according to need. The early revisions of the ‘big picture’ are documented as a current state map from where the operational model development continued. The workshop with three cross-functional teams representative of swim line owners reviewed the ‘big picture’ as a whole process. The review was based on the actual project delivered and revealed further developments needed.

Table 1
Identified operators

Swim line	Process operators		
	Operator	Internal	External
1	Customer		x
2	Sales	x	
3	Service	x	
4	Export & Trade Finance	x	
5	Project Management	x	
6	Engineering	x	x
7	Purchasing & Sourcing	x	x
8	Supplier	x	x

Define value stream

The value stream described in the old operating model was studied. It was discovered that the process allowed starting activities and tasks simultaneously before indicating that the external customer commitment was clearly done. There were also problems with the internal customers, where undefined and unfinished work was moved forward in the organisation. This generated concrete material waste and immaterial waste (Fig. 3).

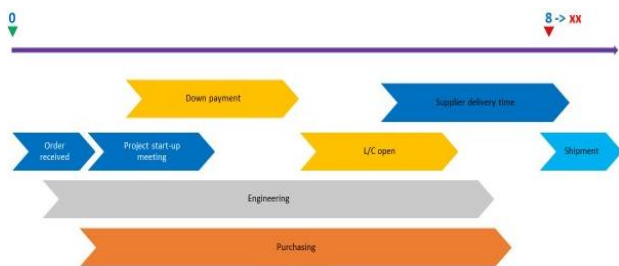

Fig. 3. Current state value stream (in large picture later)

Create continuous flow and takt connected to flow

The work with the timing model and takt time was also part of the production flow. Different production phases are connected and scheduled differently to ensure a harmonious balance between customer commitment and delivery. When the project delivery timeline and critical financial points are defined, it is possible to go deeper into the process and adjust production schedules. Model schedules are connected into product-type structures. Some tasks were forward scheduled and some backward scheduled depending on the need in the bigger picture (Fig. 4).

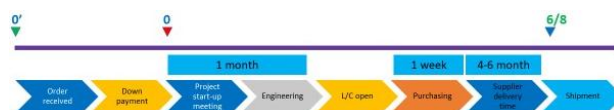

Fig. 4. Continuous flow with new value stream (in large picture later)

Waste removal in operative business level

According to Womack et al. (1990), Taiichi Ohno instructed, ‘Without standards, there can be no Kaizen’. The actual work and management processes must be standardised before possible real improvements exist. Standardisation needs to cover the whole process with every step in the model (Womack et al., 1990). In this case, the work of progress at the operative business level needed to cover the entire work chain, including products and the delivery process. The figure below shows a comparison of simplified process models before and after work (Fig. 5).

ABC-product standardization

After working with the process, it helped to realise how much additional non-value-adding work was done on product-related issues. Real problems were the number of products that were updated and kept alive without a clear need for them. The other issue was that it was not easy to find standard products from customer-tailored products when needed.

There was a need for standard product recognition, as it can benefit marketing, sales, project management, sourcing, suppliers and the aftermarket. But still, businesses need to be able to provide a tailored product to customers through separate processes.

Typically, there could be more than 450 products, with sub-products, options and variations beneath them. Also, each product must have valid electrical and mechanical structures and possible software. A pre-packing list, cost structure, risk assessment and

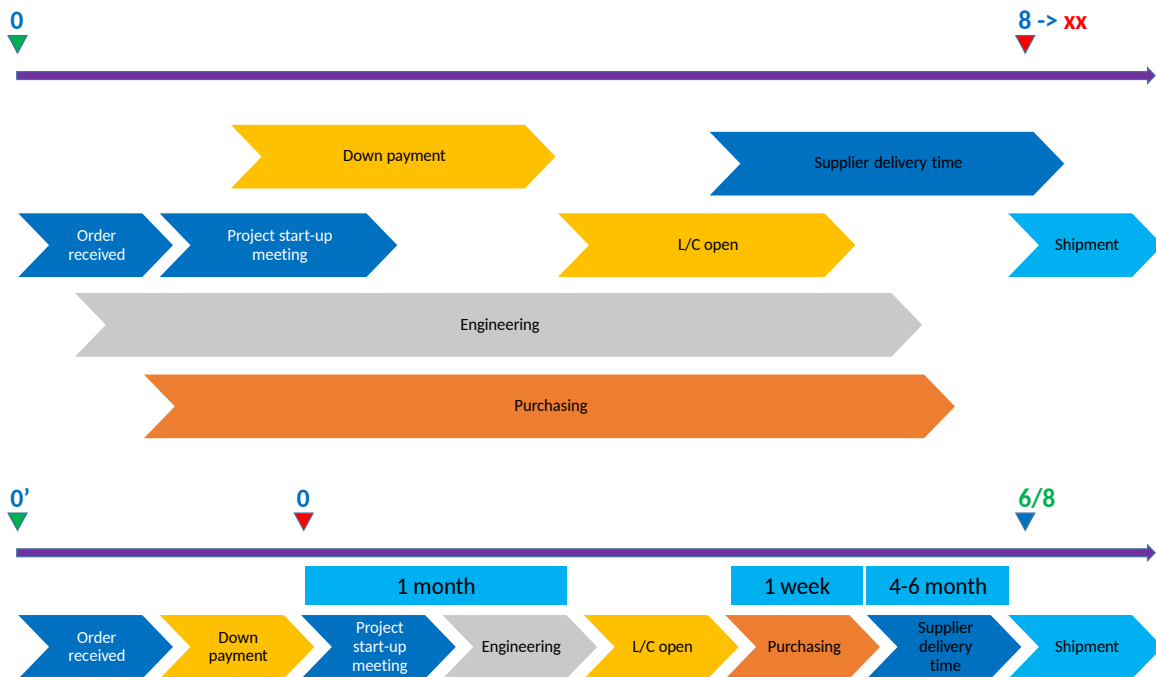

Fig. 5. Comparison of simplified process models before and after work

valid customer documentation such as operating instructions are needed. It was impossible for personnel to keep all these product structures in shape, updated and available for delivery time. The product classification was divided into the active products as A-products, old past-due date products as B-products, no longer valid A-products and customer-tailored C-products made from A and B products.

In the new product mastering model, standard and nonstandard products are clearly identified. Standard A-products have proven functionality with locked specifications made from defined parts and components. They constitute the product foundation (Fig. 6).

The A-products are updated twice a year to ensure the correct components, costs and delivery time. B and C products are not updated to save time and effort. One could even state that there is no need to order all the world's newspapers just in case when there is no usage or demand for them.

The standard A-products have connected predefined work hours needed to create the product from order to delivery, which is not visible an unknown C-product before the offer calculation has been made.

For the elimination process of old A-products, it was decided that products that don't have activity in the running year plus two previous years will automatically drop into B-class. The definition of this

A-product	B-product	C-product
<ul style="list-style-type: none"> • Known cost • Known delivery time • Known and locked specification • Proven functionality • Product updated only 2 times / year (01.06 and 01.12) 	<ul style="list-style-type: none"> • Unknown cost • Unknown delivery time • Known and locked specification • Proven functionality • Outdated A-product • Need "Offer Calculation" form 	<ul style="list-style-type: none"> • Modification into A- or B-product • Need "Offer Calculation" form • Development project • New product

Fig. 6. Product ABC-classification

time frame came from the best knowledge of typical cycles of business cases. New products are introduced into the system as B-products to ensure technical and cost structures. When new B-products are projected with warranty status, they can be awarded into A-products in the upcoming twice-a-year product update. The old dropdown B-products can lift A-products back up if they have steady demand and are evaluated case by case.

Process to offer both standardized products and fully customized white paper products

A large number of required products other than A-products became visible and pointed out that there is a need to master B and C products. Also, the time frame from the quotation phase to realised project forces us to record component-related modifications systematically. Separate offer calculation processes and tools were created, which ensure the standard way to offer customer-tailored specific products.

These products are in the quotation phase recorded and evaluated to discover possibilities and limitations to make customer-requested product. As a result of process there are collected information from additional delivery time and additional cost needed to build customer specific product or found out if suggested solution is not possible or more suitable product is available as a standard product.

The global sales organisation sets challenges in process and the time frame spend in the offer calculation process. The target time to make the requested OC-form (Offer Calculation) is a maximum of one week, which in many cases are less than target. But in more complex requests there is a need for longer time to collect all the information and solution.

When there are many quoted projects with a vast amount of customer-specific OC products, it is good to view how much extra work is needed in upcoming projects. To do that, an estimation of how many person-hours are required is necessary to complete the project. The properly filled-out OC forms with standard products estimate workload and give time to react if needed with extra resources. If the customer requests a product at an additional cost on the OC form exceeding €20,000, the project is introduced in R&D.

Process to improve standard products offering based on customer phase latent information

Collecting all the customer base requests/inputs during the running year makes it possible to create new offerings based on global customer requests. It is probably needed if customers are willing to pay for the additional feature. New products or product features from the OC database can be ranked according to how many times different requests have been made. When inputs from different types of customer requests are combined, it is possible to acquire latent information that single customers cannot describe or request. The most popular ones are studied and can be built into next year's standard offering.

The benefit of a thoroughly filled OC form is that it can be used as a readymade budgeting tool for new

products or features. Since tasks, hours needed, and cost estimates have been recorded, you won't do double work when planning a new product or product inputs. This speeds up the evaluation cycle when information collection is needed for decisions.

Measurement of progress

The changes during work were followed with different tools. On-time delivery (OTD) shows an overview of how changes affect the process of delivering new production capacity. It gives a perspective on how customer promises can be fulfilled (Fig. 7).



Fig. 7. Progress of on time delivery

The number of quality cases typically shows activities after the project's main delivery has been sent to the customer and ends before the warranty period starts. This is called post-delivery, and they are followed by the amount per month. Post deliveries can be tracked by the project or deeper by a project-specific product. The amount of post deliveries per month has decreased steadily under the study timeline. The post deliveries show how accurately the main delivery has succeeded (Fig. 8).

The quality cost is divided into two classes: cost after closing the project and guarantee cost. Cost after closing the project indicates how well all goods managed to include within the actual delivery and also how much effort is needed to fulfil customer promises both product and process vice. Guarantee cost gives a view of how products stand up specific use. Change history in quality cost by year was measured during the study and showed positive trend changes (Fig. 9).

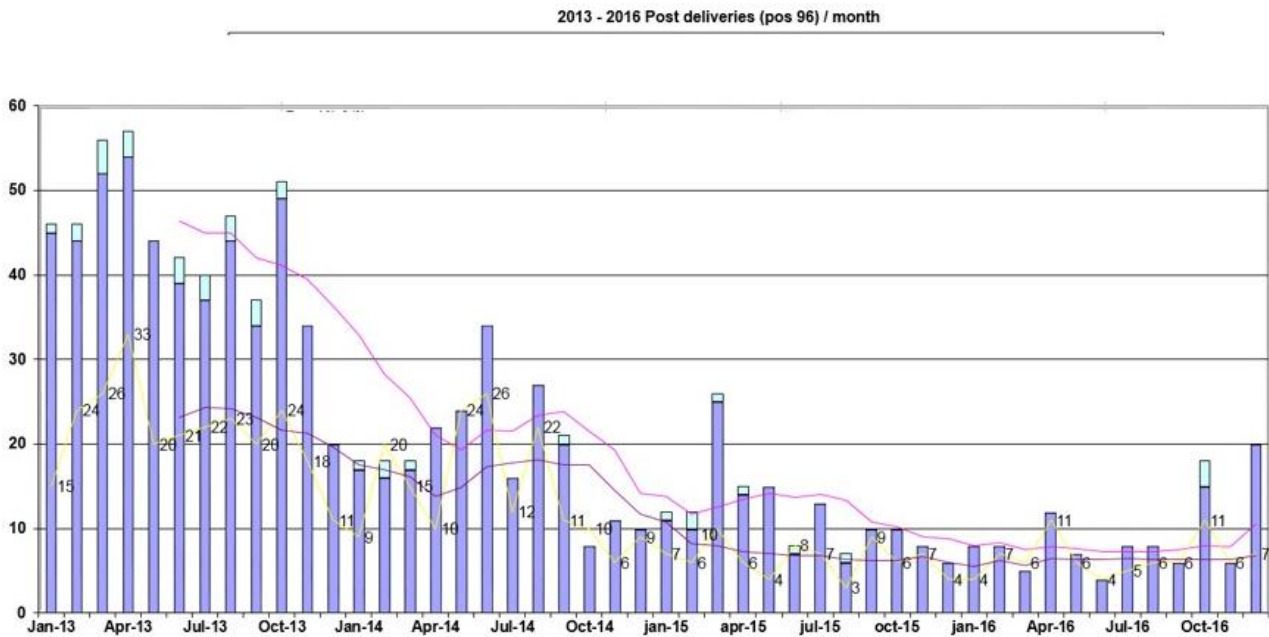

Fig. 8. Trend view of post deliveries 2013–2016

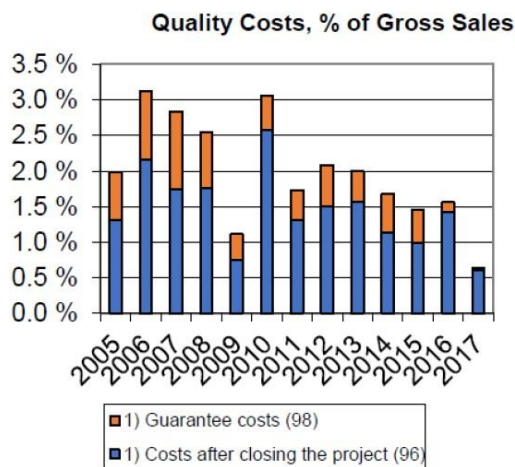

Fig. 9. Quality cost progress history

Discussion

There has always been a need to improve the efficiency and profitability of doing business. Co-evolution and continuous development are needed to keep up the phase and improve operative efficiency. History has shown old valid knowledge and tools when developing different models. The difficulty is to find and apply the correct combination of those to case-specific business segments. This study's segment consists of large project machine manufacturing busi-

nesses with long lead times from the quotation phase to accepted delivery. This also sets limitations in measuring the change. It is necessary to point out that not all the measured change is conducted in the development project in the case study. More likely, changes in the world economic situation somehow affect measured results.

In the project business, the business model is easily non-standardised and reflects more customer-oriented flexibility. This presents conflicts and challenges when the target is to standardise the operative model. Preferred key factor is to maintain needed project business flexibility towards customers.

The business transition needs a co-operatively defined measuring system to view development progress correctly. Since all the changes are not always wanted and there is a need to redefine and re-adjust direction, the following research question was posed: How to measure the change and development of business structures and elements?

The development process described by both [Womack & Jones \(1990\)](#) and [Liker \(2004\)](#) were combined in the study. Equally important is recognising the need for standardisation and pursuing it. Before the undefined grey boxes in products and operational processes have been removed, it is difficult to measure the development progress of those.

First, there is a need for current state analysis to determine where the issues to be developed are and their urgency. Since it is impossible to change all the

upcoming issues simultaneously, it is recommended to concentrate on the critical ones that are visible. It will raise new development issues, further proceeding with the current state analysis. At some stage of drawing the 'big picture', 'Delivery of new production capacity' changes from current state analysis into a development tool for standardised operational processes.

It is essential to understand different customers in the process, internally and externally. The development process should be done with a holistic perspective of the end customer and not a partial optimisation view of the sub-process customer internally or externally. Equally important for evaluating process tasks is to understand unique and repetitive processes. These earlier mentioned issues should be considered while developing operational processes and related tasks between different sub-customer interfaces.

A clear target in operative business model optimisation is to identify the whole value stream and eliminate waste from it. The 'big picture' is a visual tool with a detailed view of the value stream and standardisation of the process from the quotation phase to the end of the delivery where the warranty begins.

The target for the value stream is to make each step to flow. When defining the value stream and takt times connected to the flow, the customer financial commitment should be at the same takt time. When customer commitment has been ensured, it opens the next steps in the operational process. There is a very limited risk of not getting end customer payment for ordered work, products or services.

As important as standardisation and waste removal are at the operational business level, they are at least equally as important at the product and product family level. Before defining the product needed in the delivery process, evaluating and measuring progress in that area is challenging. It is a competitive advantage in the project business if you provide standardised and customised white paper products. The result was to create better customer satisfaction and register globally collected latent customer phase information. This information is used in new product development inputs. Both processes – product classification and white paper product OC process – standardise and remove waste from the view of the total process.

The case study identified several suitable measurable parameters to follow, from which the most useful tools were selected based on the case study's unique customer-driven project business environment. In the long lead time business, on-time delivery describes first how the operational process is working and the goods are getting in transportation. The amount of post deliveries indicates how well all the material is

on at the original delivery and how many fixing cases are needed to cover errors in products or customer promised production process. The quality cost reveals the severity and trend in error corrections.

Conclusions

Before it is possible to utilise measuring tools in effective manner, the described base work is needed to do. When products and processes are non-standardised, it will consume time and energy to track the changes and evaluate whether or not progress moves in right direction. Since resources are limited and, in a company, you need to do daily work and not harness all resources in development projects, there is a need to make clear decisions about the most productive development tasks to do at the current moment. In the development process of business structures, a clear view of the 'big picture' is needed to create and update continuously during development progress. The business has been renewed, and the new production model has resulted in a positive change in quality, quality costs and strong development in delivery reliability.

Working with a multidisciplinary team and thinking together, it is possible to discover insights that cannot be reached individually. Without whole organisation engagement, this developed production model could not have been achieved.

References

- Chiarini A. and Vagnoni E. (2015), World-class manufacturing by Fiat. Comparison with Toyota Production System from a Strategic Management, Management Accounting, Operations Management and Performance Measurement dimension, *International Journal of Production Research*, No. 2, Vol. 53, pp. 590–606. DOI: [10.1080/00207543.2014.958596](https://doi.org/10.1080/00207543.2014.958596).
- Curcio, V. (2013), *Henry Ford*, New York, N.Y.: Oxford University Press.
- Dabhilkar M. and Åhlström P. (2013), Converging production models: the STS versus lean production debate revisited, *International Journal of Operations & Production Management*, No. 8, Vol. 33, pp. 1019–1039. DOI: [10.1108/IJOPM-08-2012-0316](https://doi.org/10.1108/IJOPM-08-2012-0316).
- Emiliani M. and Seymour P. (2011), Frank George Woolard: forgotten pioneer of flow production, *Journal of Management History*, No. 1, Vol. 17, pp. 66–87. DOI: [10.1108/17511341111099538](https://doi.org/10.1108/17511341111099538).

- Gunasekaran A. (2001), *Agile Manufacturing: The 21st Century Competitive Strategy*. London, UK: Elsevier.
- Hounshell D. (1985), *From the American System to Mass Production, 1800–1932: Development of Manufacturing Technology in the United States*. Baltimore, Maryland: John Hopkins University Press.
- Liker J. (2004), *The Toyota Way: 14 Management Principles from the World's Greatest Manufacturer*. New York, N.Y.: McGraw-Hill.
- Netland T. and Aspelund A. (2013), Company-specific production systems and competitive advantage: A resource-based view on the Volvo production system, *International Journal of Operations & Production Management*, No. 11–12, Vol. 33, pp. 1511–1531. DOI: [10.1108/IJOPM-07-2010-0171](https://doi.org/10.1108/IJOPM-07-2010-0171).
- Ohno T. (1988), *Toyota Production System: Beyond Large-Scale Production*. Cambridge, MA: Productivity Press.
- Shingö S. (1988), *Non-Stock Production*. Cambridge, MA: Productivity Press.
- Shingö S. and Liker J. (2007), *Idea wo Nigasuna/Kaizen And The Art of Creative Thinking*. English Translation, Tokyo, Japan/Bellingham, WA: Hakuto-Shopo Publishing Company/Enna Products Corporation.
- Wilkins M. and Hill F.E. (2011), *American Business Abroad Ford on Six Continents*. Cambridge, UK: Cambridge University Press.
- Womack J. and Jones D. (1996), *Lean Thinking*. New York, N.Y.: Free Press.
- Womack J., Jones D. and Roos D. (1990), *The Machine That Changed The World*. New York, N.Y.: Free Press.
- Woollard F. (1954), *Principles of Mass and Flow Production*. London, UK: Published for Mechanical Handling [by] Iliffe.
- Yusuf Y., Sarhadi M. and Gunasekaran A. (1999), Agile Manufacturing: The Drivers, Concepts and Attributes, *International Journal of Production Economics*, No. 1, Vol. 62, pp. 33–43. DOI: [10.1016/S0925-5273\(98\)00219-9](https://doi.org/10.1016/S0925-5273(98)00219-9).