

Monitoring of active destructive processes as a diagnostic tool for the structure technical state evaluation

B. GOSZCZYŃSKA*, G. ŚWIT, and W. TRĄMPCZYŃSKI

Faculty of Civil and Environmental Engineering, Kielce University of Technology,
Al. Tysiąclecia Państwa Polskiego 7, 25-314 Kielce, Poland

Abstract. In this paper, a global monitoring system based on the measurement of acoustic emission (AE) due to active deterioration processes is presented. This allows us to examine the entire volume of an element and to locate and identify the type and the dynamics of the deterioration processes under service conditions. The resulting data are used to determine and locate the damage processes that are dangerous in construction made of pre-stress concrete, steel and fiber glass and to assess the general condition of the structure.

Key words: monitoring, destructive process, destructive process location, model AE database for damage processes, service load.

1. Introduction

In recent years much attention has been paid to issues of diagnostics and monitoring of building structures in service, which is related to their durability and reliability [1–6].

In EN 1990 Eurocode, Basis of Structural Design, a requirement for durability has been set, which states that “the structure shall be designed such that deterioration over its design working life does not impair the performance of the structure below that intended, having due regard to its environment and the anticipated level of maintenance”.

Providing for structure reliability is based on quality management strategies, in which one of the means are regular inspections carried out at the design, execution and maintenance stages. The duty of conducting routine inspections of the technical state of building structures at the maintenance stage has been prescribed by law under Article 6 of Polish Construction Law on maintenance of building objects.

It is therefore necessary to develop a comprehensive system for quality management in construction, based on research methods which will make it possible to provide factual technical evaluation of a building structure. The system should account for the full effect produced by the environment, thus allowing structures to be monitored for safety and predicting their durability. In particular, that refers as well to reinforced and pre-stressed concrete structures as to steel structures because a large percentage of those have reached the stage in which they face increased failure risk, or their age approaches design service life. Reliability and durability of those structures often concerns faults that are not visible on the surface of elements, or are located at inaccessible sites. Other factors that affect the health of those structures are reinforcement state and distribution and concrete adhesion to steel.

Steady progress in information technology and research facilitates causes the development of non-destructive methods that can be used to evaluate performance and technical

state of building and engineering structures [7]. It is, however, difficult to decide which of those methods is optimal and how reliable are the results it yields. It must be remembered that the results are not only affected by the accuracy of the apparatus, but also by the selection and accessibility of the examined area, the structure loading during tests and external conditions.

It is therefore necessary to develop objective methods in order to evaluate workmanship and to conduct inspections of building and engineering structures while those are continuously in service. To a far extent, that refers to bridge structures because overpass or bridge temporary shutdowns generate substantial economic, social and environmental losses.

Properly conducted bridge monitoring and diagnosing should help management staff (owners) to supervise those structures and prolong their service life, thus, to optimise the schedule and scope of rehabilitation works, repairs or strengthening, or when damages that threaten the structural safety are revealed, to decide to shut down a structure if justifiable

In accordance with [2–5], monitoring systems should focus on recording two issues, i.e. changes proceeding in the load structure and damage accumulation. Having a damage identified by inspection and described is not equivalent to knowing the hazard the damage poses to the structure safety. International programmes on diagnostics, therefore emphasise a need to develop non-destructive methods that will make it possible to provide overall evaluation of such structures. Acoustic methods, which have been developing robustly in recent years, aim to provide means of obtaining reliable information on an object under investigation or a whole structure.

Those include the method based on measurements and analysis of acoustic emission (AE) signals, and consequently, on monitoring active destructive processes in the examined element or the whole structure. That underlies the diagnos-

*e-mail: b.goszczyńska@tu.kielce.pl

tics of the whole structure (with measurements covering the whole of the structure or its selected part) operating under actual service load [8–14].

2. The method fundamentals

The method relies on the analysis of acoustic waves generated by active destructive processes that develop in engineering structures under service loads. The signals received by acoustic sensors located on the structure are compared with reference signal database compiled beforehand for specific destructive processes. Thus identified destructive processes are located due to the analysis of differences in time-of-arrival of signals at individual sensors. Identification and location of active destructive processes provides a basis for monitoring which, together with the analysis of the intensity of those processes, makes it possible to evaluate the technical state of structures [15–18].

The advantage of the method lies in the fact that it is possible to space sensors in such a way that their measurement ranges cover the whole of the examined structure. Another benefit is that monitoring and diagnostics can be conducted while the structure is under real service load.

2.1. Acoustic wave. Acoustic Emission (AE) is a transient elastic wave generated due to a rapid release of the energy accumulated in the material by propagating micro-damages (micro-crack growth, the movement of vacancies and dislocations, crack initiation and development, phase changes in the crystalline structure). The attenuation of the wave results from absorption, the conversion of elastic strain energy to thermal energy. AE formation is thus a sign of the degradation of the properties of the material (and of a given component of the structure).

The elastic wave (AE) that is released is recorded by sensors mounted on the structure and then analysed by a computer. Most frequently, those are piezoelectric sensors operating in 0.1–2.0 MHz range, which defines the frequency range of the wave that is received. The diagram showing wave generation by destructive processes is presented in Fig. 1 and a typical shape of the acoustic wave is shown in Fig. 2. Such waves can be characterised by several wave parameters, but in presented method following twelve parameters were taken into account: counts, counts to the peak amplitude, signal duration, signal rise time, signal amplitude given in mV or dB, signal energy, signal strength, average effective voltage, average signal level, average signal frequency, reverberation frequency and initiation frequency.

Processes generating AE signals accompany only active damages, i.e. those that are initiated or propagate under conditions prevailing at the instant at which measurements are taken. AE signals are not generated by defects which are physically present in the structure but do not develop. Consequently, it can be assumed those do not pose a threat to the structure integrity.

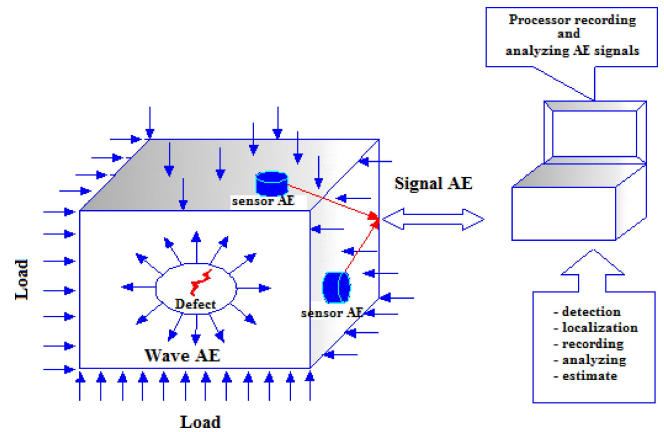

Fig. 1. Diagram of wave generation by destructive processes and wave recording

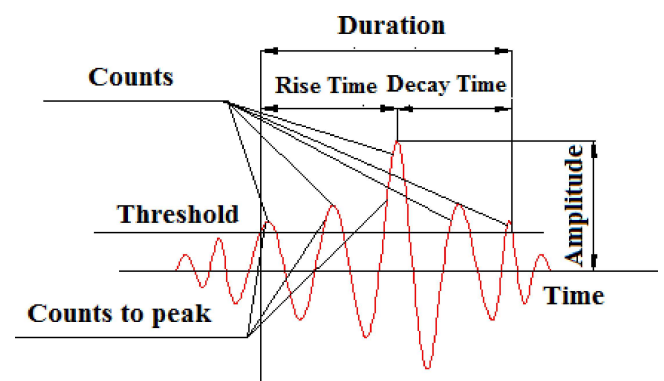

Fig. 2. A diagram of typical shape of acoustic emission signal

2.2. Reference signal database. Reference database of acoustic signals for individual destructive processes is compiled owing to tests of materials specimens and models, carried out under laboratory conditions, and also strength tests of full-scale elements of structures and tests conducted on actual structures in service.

Reference signal database – pre-stressed concrete structures. For pre-stressed concrete structures the following destructive processes, which are also AE sources, can be differentiated [15]: micro-cracks, friction between crack surfaces, initiation and development of cracks in the concrete, cracks at the concrete-reinforcement interface, concrete crushing, friction at the reinforcement-concrete interface, corrosion, plastic deformation and fracture of cables and other reinforcements

Reference signal database was compiled by means of conducting a number of tests on various types of specimens for different loading schemes. Tests were designed to obtain a single dominant destructive process among those that can occur in concrete structures under investigation, in this case pre-stressed ones.

Tests were carried out on specimens and elements shown in Fig. 3 and on model beams of reinforced and pre-stressed concrete of the following dimensions: 100 × 200 × 1500 mm, made of C30/35 and C40/50 concrete [19].

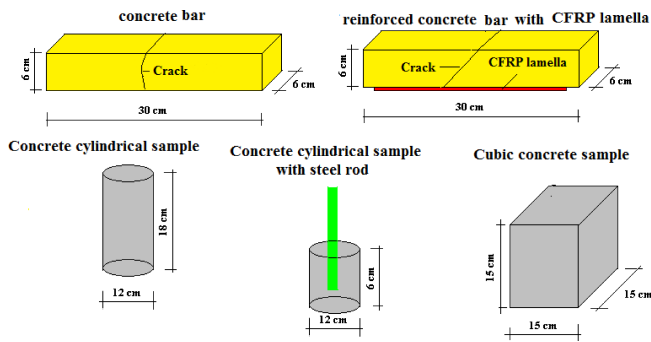

Fig. 3. Specimens used to obtain reference signals

Tests on concrete beams have been intended to select acoustic emission signals generated during crack formation in the concrete and at the cement paste-aggregate interface. On cylinder specimens, signals generated in compression are obtained. Additionally, the Brazilian test was applied, in the result of which separation crack, caused by tension, was produced.

Specimens with embedded steel rods have been used to obtain signals generated during destructive processes at the concrete-reinforcement interface while the rods were being drawn out. At a plant prefabricating pre-stressed elements, reference signals generated in plasticization and tendon rupture were obtained.

Reference databases were classified on the basis of twelve parameters of the AE signal and denoted as Classes [15, 16, 19–21]:

- Class 1 – Micro-cracks in the concrete at the interface of the small-sized ($\Phi \leq 2$ mm) aggregate fraction and cement paste,
- Class 2 – Micro-cracks in the concrete at the boundary of the medium- and small-sized ($\Phi \leq 8$ mm) aggregate fraction,
- Class 3 – Crack initiation in the concrete tension zone,
- Class 4 – Crack development,
- Class 5 – Cracking at the concrete-reinforcement interface,
- Class 6 – Plastic deformation of steel and concrete,
- Class 7 – Concrete delamination,
- Class 8 – Rupture of prestressed tendons.

For instance, a signal corresponding to Class 4 indicates crack initiation.

Destructive processes were classified with respect to the hazard they pose to a structure. The degree of hazard corresponds to signal Classes:

- occurrence of Class 3 signals indicates a potentially danger condition,
- occurrences of Class 4 and 5 signals indicate a progressively danger condition,
- finally, occurrences of Class 6, 7 and 8 signals indicate a particularly dangerous deterioration process.

Individual classes were denoted with different symbols and colours, which are shown in Fig. 4.

Shape / Color							+	X
Class number	Nr1	Nr2	Nr3	Nr4	Nr5	Nr6	Nr7	Nr8

Fig. 4. Symbols attributed to numbers of classes of reference signals generated by destructive processes

Reference signal database – steel structures. Reference database for steel structures were compiled in a similar way as for pre-stressed concrete structures. Tests were conducted on smooth specimens and those with a notch, in monotonic loading, within temperature range from -60° C to $+60^{\circ}$ C. Specimens were made of St3s, 18G2A steels and the steel taken from a bridge structure. Also models of elements with a notch, made of the same steel types were put under monotonic and cyclic bending at the temperature of $+20^{\circ}$ C. The following reference databases were obtained:

- Class 1 – signals related to the structure performance, e.g. steel strains in the elastic range, thermal strains, etc.,
- Class 2 – plastic deformation of steel at the crack tip,
- Class 3 – crack initiation,
- Class 4 – crack growth,
- Class 5 – signals resulting from the superposition of waves generated by more than one destructive process, and by crack surface friction which precedes the element failure.

Symbols and colours presented in Fig. 5 mark classes of reference signals for steel [18, 21].





Shape / Color					
Class number	Nr 1	Nr 2	Nr 3	Nr 4	Nr 5

Fig. 5. Symbols attributed to numbers of classes of reference signals generated by destructive processes

AE signals accompanying destructive processes were classified on the basis of twelve selected parameters by means of the pattern recognition method.

2.3. Groups of AE signals – pattern recognition. Statistical analysis, based on pattern recognition, was applied to recorded acoustic emission signals using NOESIS software. Pattern recognition can be categorised into: arbitrary classification using *unsupervised (USPR)* learning procedure and classification that employs the training set, in the form of reference signals, in the *supervised (SPR)* learning procedure [19, 22].

In order to compile a database (signal classes), arbitrary pattern analysis was used, whereas for signal class recognition, supervised analysis was applied.

As regards statistical methods applied to item recognition, it is important to optimally select recorded parameters of acoustic emission. Because many parameters of acoustic emission show strong mutual correlation, which makes it possible for them to carry the same information on an AE source, the degree of correlation between those parameters is defined by the so called dendrograms. Using them, one can reduce

the number of parameters of AE signals in the classification process, which shortens the duration of the analysis. Twelve parameters of AE signals, with different level of adjustment, were adopted for analysis. An exemplary dendrogram for AE parameters recorded in tests on a steel beam is presented in Fig. 6.

In the analysis, iterative grouping was applied. It involves an iterative search of a set of reference elements which represent individual classes. In each iteration, successive approximations of reference elements are sought. Depending on the assumptions made, one of the elements of \mathbb{X} population can become a reference element, or it can belong to a certain Universum $U \supseteq \mathbb{X}$. In metric spaces, the reference element is computed as an arithmetic mean and it represents a centroid of the class. Algorithms based on this type of grouping include, e.g. *k-means* algorithms.

The method belongs to a non-hierarchical group algorithms, which essentially consist in randomly selecting the position of class centres. In successive iteration steps, after the functions that points belonging to class centres are computed, those are recomputed every time. Such a procedure makes class centres seek their correct locations while using the following dependence (1):

$$\underline{\mu}_j = \frac{\sum_{j=1}^n P(\omega_i | \underline{x}_j)^b \underline{x}_j}{\sum_{j=1}^n P(\omega_i | \underline{x}_j)^b} \quad (1)$$

where $P(\omega_i | \underline{x}_j)$ is a conditional probability of the association of j -th element with the i -th class, b – parameter, the

value of which must be different from 1.

The association function is normalised in accordance with formula (1):

$$\sum P(\omega_i | \underline{x}_j) = 1, \quad \text{where } j = 1, \dots, n. \quad (2)$$

The probability of an element association with each class $P(\omega_i | \underline{x}_j)$ is calculated from formula (3):

$$P(\omega_i | \underline{x}_j) = \frac{\left(\frac{1}{d_{ij}}\right)^{\frac{1}{b-1}}}{\sum_{r=1}^c \left(\frac{1}{d_{rj}}\right)^{\frac{1}{b-1}}}, \quad (3)$$

where $d_{ij}^2 = \|\underline{x}_j - \underline{\mu}_i\|^2$ is point \underline{x}_j distance from the class centre $\underline{\mu}_i$.

The operation of a K-means algorithm can be shown as composed of the following steps:

1. Randomly selecting the position of centres of classes that are sought,
2. Computing distances of points from class centres,
3. Computing values of association functions for all elements $P(\omega_i | \underline{x}_j)$,
4. Computing class centres $\underline{\mu}_i$,
5. If:
 - No changes in $\underline{\mu}_i$ and $P(\omega_i | \underline{x}_j)$ – return to the beginning $\underline{\mu}_1, \dots, \underline{\mu}_c$
 - Otherwise, return to step 2.

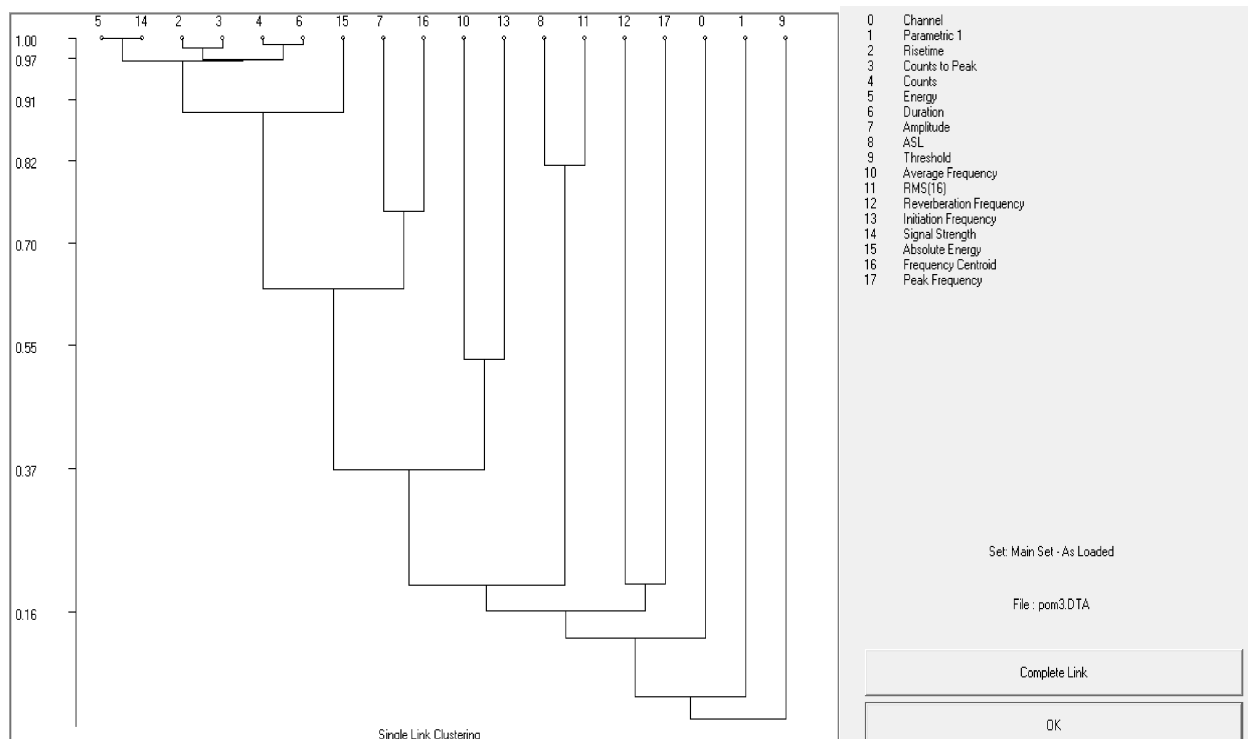

Fig. 6. Dendrogram specifying a degree of correlation between individual AE parameters

Unfortunately, it is obligatory to pre-determine a number of classes for such an algorithm. This drawback, however, is compensated for by the speed of computation and the fitting [10, 20].

In the first stage, the unsupervised method was used to optimally classify the signals depending on the character of operation.

An important issue that may affect the computation accuracy, and which should be taken into account, is the number of iterations necessary to obtain satisfactory results.

For steel elements, five-class categorisation was used because of correlations between parameters, whereas for pre-stressed post-tensioned elements eight-class categorisation was applied at iterations (Figs. 4, 5). The results obtained made it possible to establish groups of reference signals which were later employed in the analysis of remaining specimens.

2.4. Location [17, 19, 20]. An elastic wave (AE) released in a destructive process is recorded by sensors mounted on the structure. The measurement range of sensors (for acoustically isotropic body) is a spherical cap of radius "a" (Fig. 7), the size of which depends on the signal strength, signal attenuation and the sensitivity of a sensor. Assuming that radius "a" corresponds to a distance that ensures definite attenuation (e.g. 10 dB) of a signal, it can be determined experimentally.

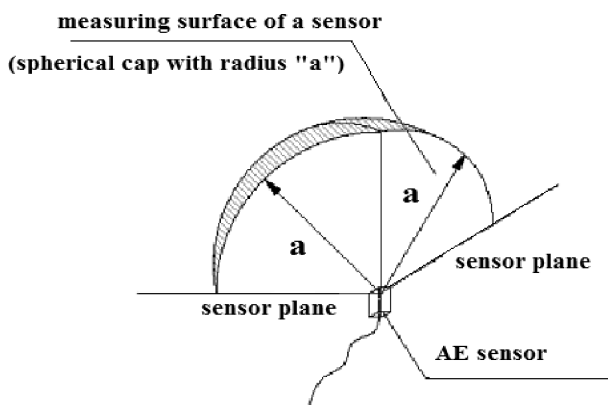

Fig. 7. Sensor measurement area

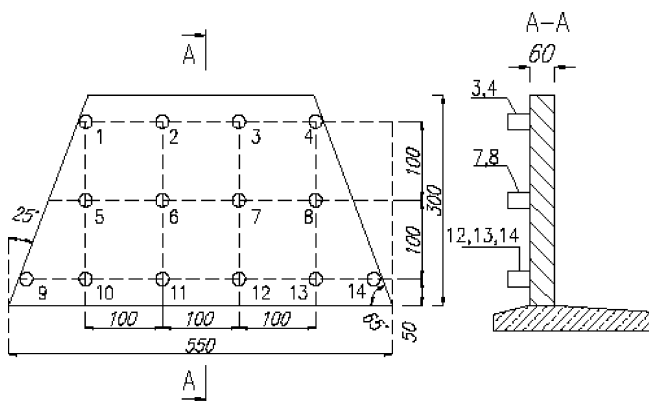

Fig. 8. Spacing of sensors, the measurement zones of which cover the whole volume of the retaining wall

Monitoring can be conducted at either of two levels. At a global level, the whole of the load-bearing structure is covered (Fig. 8), or a partial level where a selected fragment of the structure is examined. In the first case, sensors must be located in such a manner that all area under investigation is enclosed in their measurement range.

In tests run so far, which focused mainly on bridges beams, two types of location were used, namely zonal location and location in a plane [17, 20].

Zonal location. In the case presented in Fig. 9, where acoustic sensors are located at the bottom of a beam, a signal from an arbitrary point in the sensor 3 measurement zone is faster to reach sensor 3 than sensors 2 and 4 (after the signal is recorded by sensor 3, the device automatically cuts off measurements by sensors 1, 2, 4 and 5). As a result, an AE point is ascribed to the measurement zone of sensor 3. The size of the zone for a given beam depends on sensor spacing *d* (in tests run so far beams were 0.6 m in height, *d* = 1-1.5 m) [15-17].

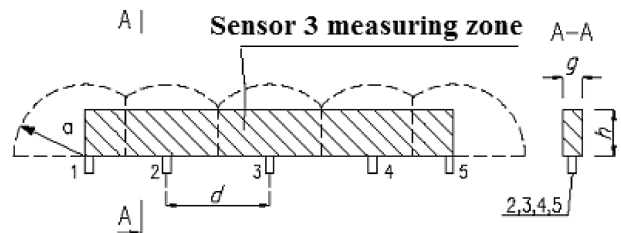

Fig. 9. Measurement zones covering all the examined beam

Location in a plane. The position of the plane normal to the line 1-2 connecting the sensors (Fig. 10) [20], in which the AE signal source is located, can be determined on the basis of the difference in the time-of-arrival of signals Δt at sensors 1 and 2.

$$b_1 = \frac{b + (\Delta t * V)}{2},$$

$$\Delta t * V = \sqrt{\left(\frac{b + \Delta b}{2}\right)^2 + a^2} - \sqrt{\left(\frac{b - \Delta b}{2}\right)^2 + a^2}, \quad (4)$$

where *b* – the distance between sensors, *b*₁(*b*₂) – the distance between the AE source and sensor 1 (2) along line 1-2, $\Delta b = b_1 - b_2$.

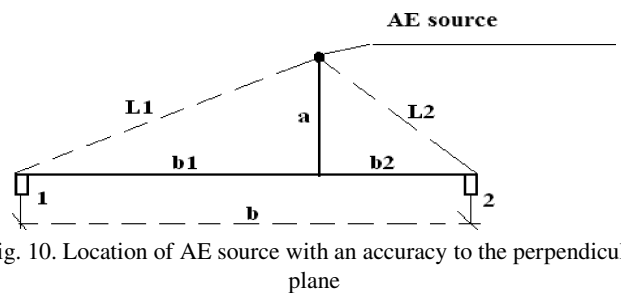

Fig. 10. Location of AE source with an accuracy to the perpendicular plane

When sensors 1 and 2 spacing, the acoustic wave velocity *V* and Δt are known, it is possible to precisely determine the

position of the AE signal source if it is located in the line connecting both sensors ($a = 0$).

For $a > 0$

$$\Delta t * V = L_1 - L_2, \text{ and assume that, computed for } a > 0, b_1 = \delta_1 \quad (5)$$

which means that although the signal source is located in the plane which is at distance b_1

from sensor 1, from the measurement, the plane at distance b_1^* will be defined, so the plane offset will be

$$d = b_1 - b_1^* \quad (6)$$

For $b_1 = 0.8$ m and $a = 0.3$ m, $V = 3400$ m/sec, value $d = -0.053$ m, which is an accuracy over an order of magnitude higher when compared with zonal location accuracy, where $d = 1$ m.

Location in plane makes it relatively simple to define the plane in which acoustic signals occur in “flat” elements (Fig. 9), for which $h > g$, such as beams, walls, etc. In order to increase the accuracy in determining the plane, another row of sensors can be used (e.g. on the surface of the element) diminishing the value of a_{max} .

Validation of the location of destructive process. Visual observations in laboratory tests and, also those made in situ at bridge structures, indicate that for Zonal location it is possible to determine areas of crack growth (Class 4 signals for concrete structures and Class 2 signals for steel structures), and when monitoring is conducted – to trace the growth of those areas [20].

Tests on reinforced concrete beams show that using “in-plane” location makes it possible to trace the initiation and growth of individual cracks (Figs. 11 and 12).

Figure 11 shows located acoustic signals corresponding to Classes 3 and 4 during a beam loading process, in which shearing is dominant (rise time parameter as a function of position). In Fig. 12, cracks being initiated and growing (brighter colours), corresponding to those signals, are shown on the beam surface. They were identified using 3D optical scanner. A good correlation between acoustic location of initiated and growing cracks and their visual observation can be seen.

It should be mentioned that not all cracks that are identified acoustically, are found on the surface observed.

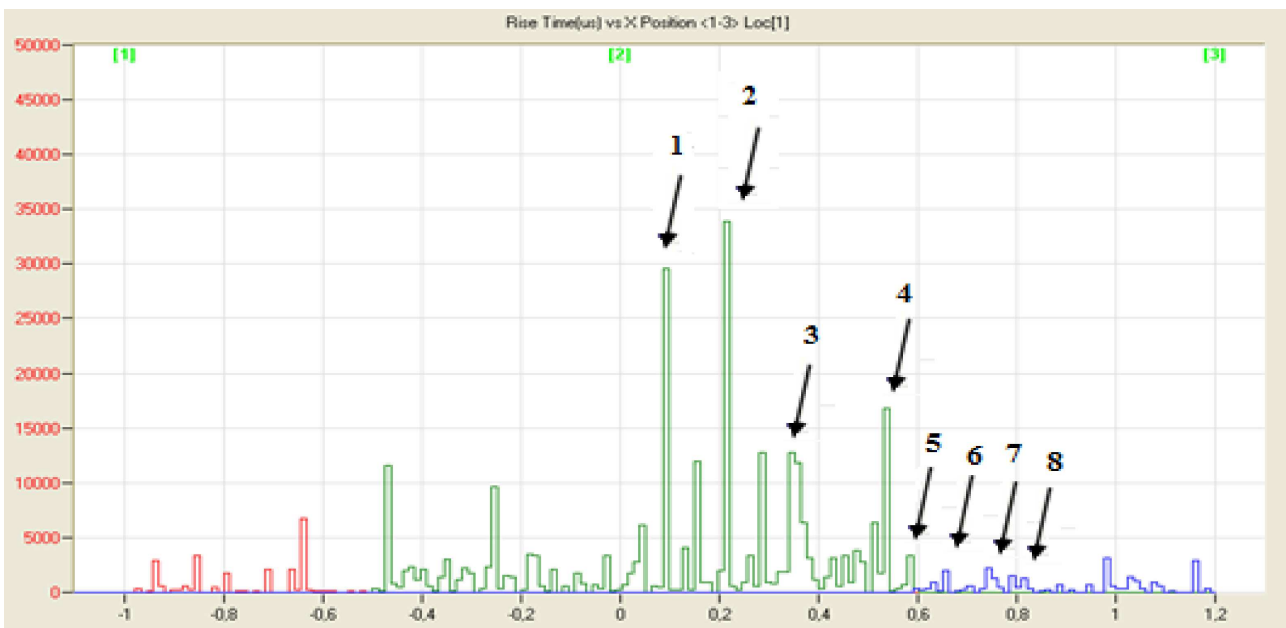

Fig. 11. Location of Class 3 and 4 AE signals

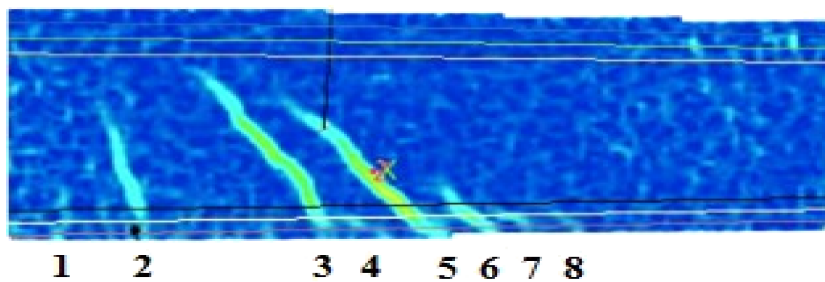

Fig. 12. Location of crack initiation and growth – 3D imaging with optical scanner

3. AE method application to monitoring and diagnostics

3.1. AE method application to the diagnostics and monitoring of pre-stressed structures. The structure under investigation, which was built in the 1950s, was a bridge over railway line. Visible damages which indicated progressive deterioration of the structure and ever increasing traffic congestion led to taking a decision on the monitoring of the structure. The structure of a span consist of seven beams, pre-stressed with Freyssinet cables, connected as monolith to the bridge deck slab made of reinforced concrete. Selected beams were subjected to monthly AE tests conducted while the bridge was in service. Exemplary results of monitoring of the same Pr 7 beam of the span, carried out in the years 2006–2010 are presented in Tables 1–3.

55 kHz eleven resonance sensors (Fig. 13), were linearly spaced on the bottom beam surface, thus making eleven measurement zones (Z 1–11). The distance between sensors was 160 centimetres [17, 19]. Such a distance is sufficient to record all AE signals from the whole beam volume.

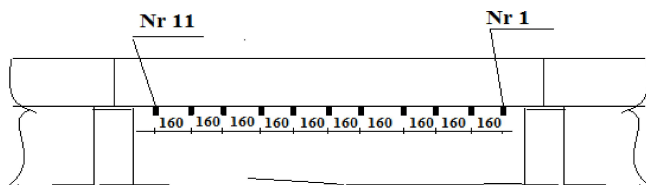

Fig. 13. Diagram of the beam under investigation and measurement sensor spacing

In tests, Zonal location was used, which means AE signals were recorded only by the sensor that was closest to the signal source.

The results of tests conducted in 2006 are presented in Table 1. Numerous active (growing) damages, covering a large area, were found in the beam. AE signals, denoting formation of micro-cracks, were detected in following zones:

- Class 1 – zones Z1–Z11,
- Class 2 – zones Z-3, Z-5 and Z-6.

Table 1

Description of active destructive processes in Pr 7 beam in 2006

	Class 1	Class 2	Class 3	Class 4	Class 5	Class 6	Class 7	Class 8
Zone 1	x							
Zone 2	x							
Zone 3	x	x						
Zone 4	x							
Zone 5	x	x						
Zone 6	x	x						
Zone 7	x							
Zone 8	x							
Zone 9	x							
Zone 10	x							
Zone 11	x							

The results of tests conducted in 2008 are presented in Table 2. It has been found that destructive processes were active and they caused increasingly quick degradation of the structure and following AE signal Classes were detected:

- Class 1 – zones Z1–Z11,
- Class 2 – zones Z1–Z10,
- Class 3 – zones Z1–Z11, potentially danger condition,
- Class 4 – zones Z2, Z4–Z5, Z10. progressively danger condition.

Table 2

Description of active destructive processes in Pr 7 beam in 2008

	Class 1	Class 2	Class 3	Class 4	Class 5	Class 6	Class 7	Class 8
Zone 1	x	x						
Zone 2	x	x	x					
Zone 3	x	x						
Zone 4	x	x	x	x				
Zone 5	x	x	x	x				
Zone 6	x	x						
Zone 7	x	x						
Zone 8	x	x						
Zone 9	x	x						
Zone 10	x	x	x	x				
Zone 11	x							

It was stated that the structure should undergo renovation at the earliest possible time; until repair works were to start, the vehicle weight was limited to 8 tonnes.

The results of tests conducted in 2010 are presented in Table 3. In spite of limiting vehicle weight, numerous active damages have been found:

- Class 1, 2 – zones Z1–Z11,
- Class 3 – zones Z2–Z8, Z10–Z11, potentially danger condition,
- Class 4 – zones Z5–Z6, Z8, Z10–Z11, progressively danger condition,
- Class 5 – zones Z2, Z4–Z5, Z10. progressively danger condition.

Table 3

Description of active destructive processes in Pr 7 beam in 2010

	Class 1	Class 2	Class 3	Class 4	Class 5	Class 6	Class 7	Class 8
Zone 1	x	x						
Zone 2	x	x	x					
Zone 3	x	x	x					
Zone 4	x	x	x					
Zone 5	x	x	x	x				
Zone 6	x	x	x	x				
Zone 7	x	x	x					
Zone 8	x	x	x	x				
Zone 9	x	x						
Zone 10	x	x	x	x				
Zone 11	x	x	x	x	x			

Destructive processes accelerated as Class 3 signals appeared in new zones: Z-3, Z-6, Z-7, Z-8 and Z-11, Class 4 signals appeared in new zones Z-6, Z-8 and Z-1, and Class 5 signals were found in zone Z-11.

The processes of degradation of the bridge have advanced, which as repair works have not been carried out, can lead to the structure damage.

The use of the AE method for monitoring the structure made it possible not only to trace damage development but also to take action, which in that instance was limiting vehicle weight, to prolong safe service life of the structure until funds for renovation were obtained.

3.2. AE method application to the diagnostics and monitoring of steel structures.

Diagnostics and monitoring of bridges. The AE method was applied to tests on the three-span riveted steel railway bridge. The bridge spans, symmetrical in the longitudinal and

lateral directions, were designed as an array of single-span trusses (Fig. 14).

Twenty three acoustic sensors were spaced along the bridge stringer (Fig. 14) and on selected support nodes (Fig. 15).

Exemplary results of tests with the use of AE method, for the bridge under dead load and live load in the form of train travelling over the bridge, are presented in Figs. 16 and 17.

On the basis of measurement results of acoustic emission presented in Figs. 16 and 17 it can be stated as follows:

- signals recorded for the bridge without live load were classified as belonging to the elastic strain range, which do not pose a hazard to the technical state of the structure,
- single signals in the zones of sensors 10 and 16 recorded while a train was moving along the bridge indicate a possibility of local yielding of steel. Damaged rivets were found in this place. The remaining sensors recorded signals within the elastic strain range, which do not pose a hazard to the technical state of the bridge.

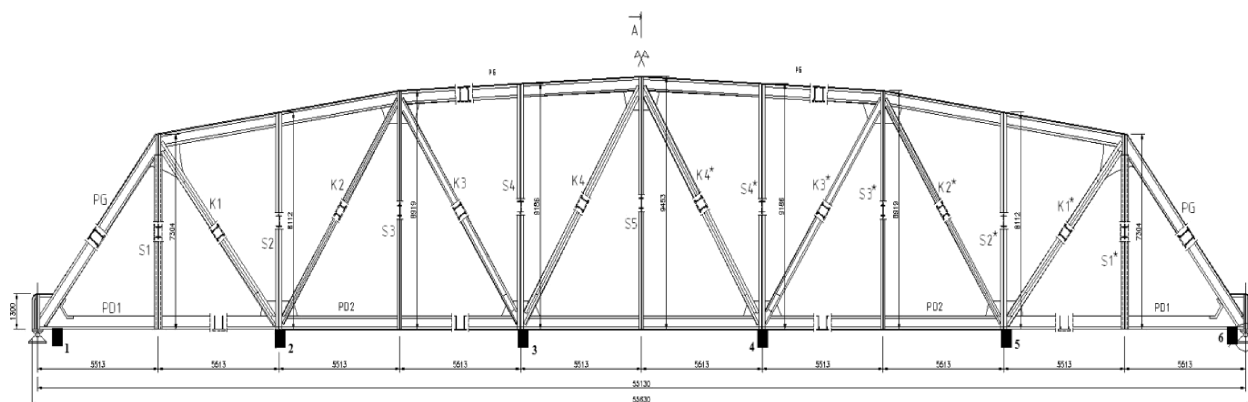

Fig. 14. Examed bridge span with sensors spaced on the bridge stringer (sensors 1, 2, 3, 4, 5, 6)

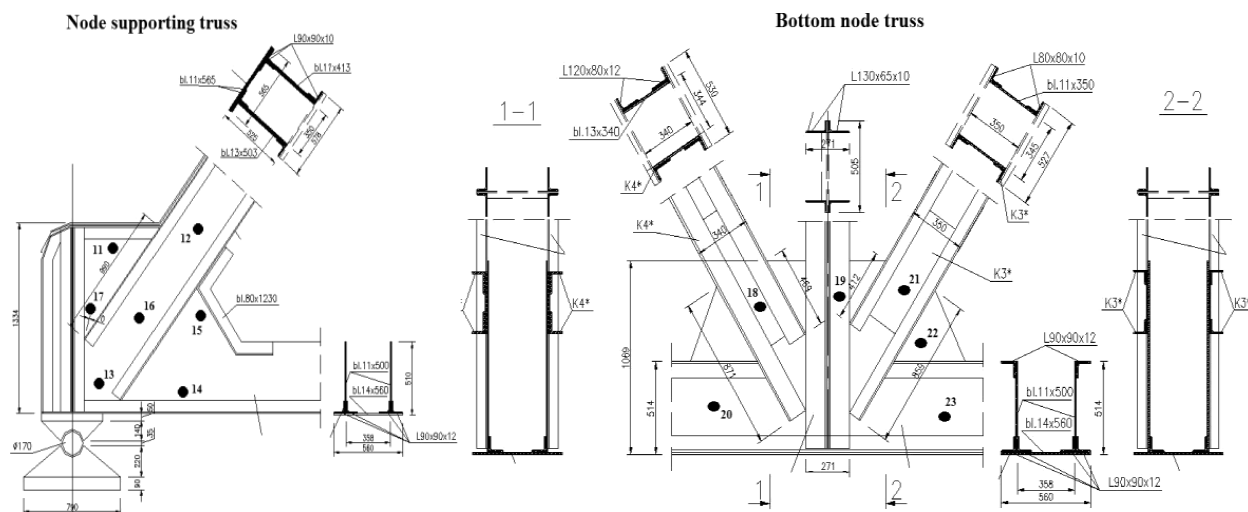

Fig. 15. Sensor spacing on the surface of selected support nodes

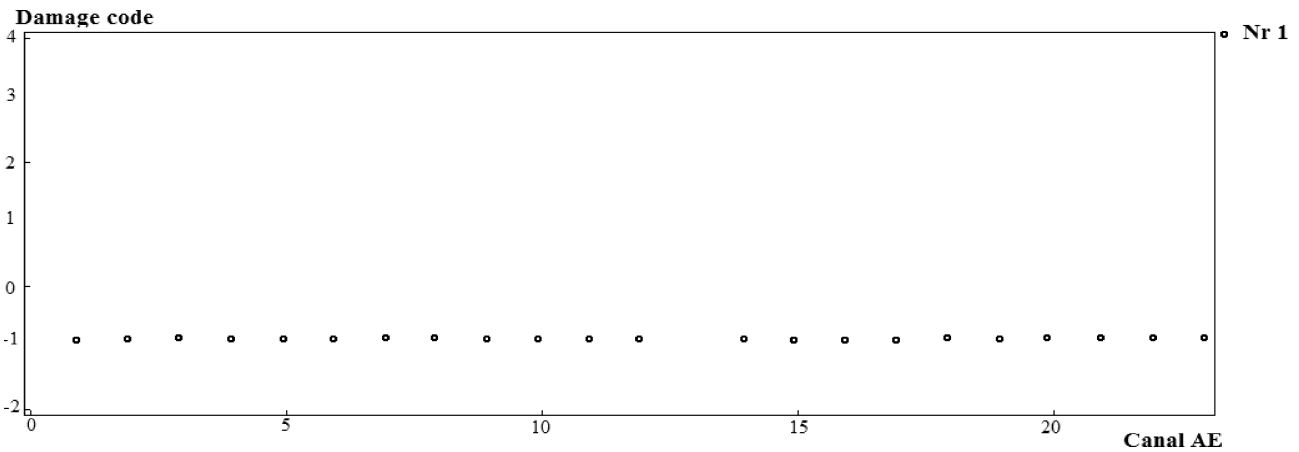

Fig. 16. Signal classes recorded by individual sensors for the bridge under dead load – the only signals recorded were those indicating the absence of destructive processes (Class –1 – circles)

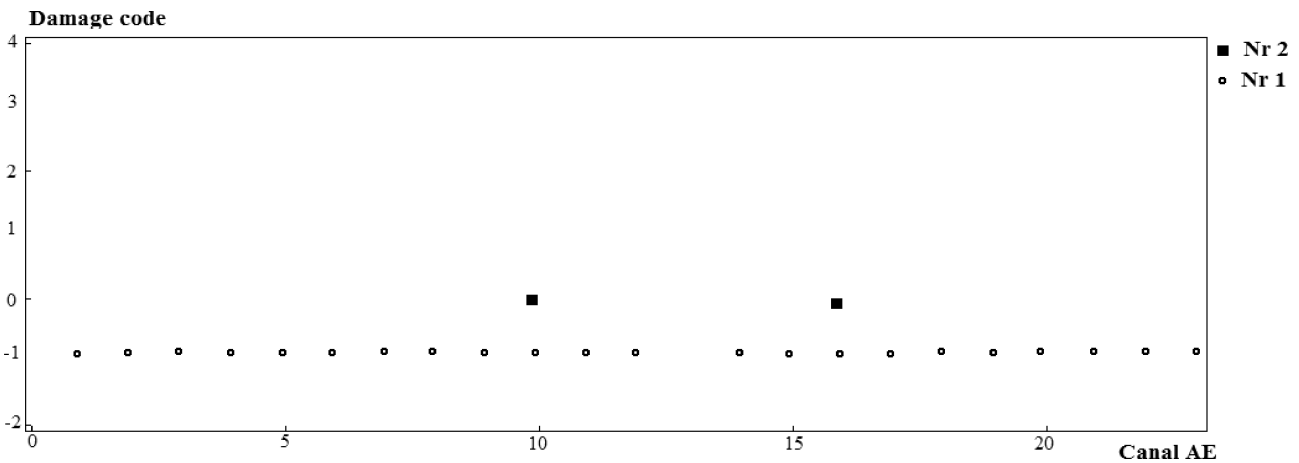

Fig. 17. Signal classes recorded by individual sensors for the bridge under live load from a moving train – recorded signals indicated the absence of destructive processes (Class –1 – circles) and yielding in the zones of sensors 10 and 16 (Class 0 – rectangles)

Monitoring of corrosive processes. Investigations into acoustic emission application to the analysis of destructive processes, in spite of that carried out by authors, have also been conducted at Cracow and Warsaw Universities of Technology [23–27]. Those focus mainly on detecting corrosive and delamination processes in steel elements. The detection of such processes provides basis for monitoring and diagnosing of bridges, chemical and petrochemical installations.

In order to identify acoustic signals due to corrosive damages the Visual Class software by Vallen Systeme GmbH was used, which for recognizing waveform similarities employs frequency analysis based on Pattern Recognition [22, 23].

This method is based on a different approach to the analysis of AE signal descriptors which is different from the one presented before, where different active damage processes were distinguished.

For the signal analysis, to assign similar waveforms to individual classes (groups), they are used frequency descriptors, i.e.:

- full AE waveform and shape and its frequency components (Fourier transforms),
- peak amplitude and component amplitudes,
- effective (RMS) value of the signal and the impulse signal energy.

In this approach, waves having similar parameters are sought. It constitutes a major difference from the approach adopted for damage processes recognition, where twelve parameters of acoustic emission, classified with statistical methods, are used.

Schematic representation of individual steps in such analysis is shown in Fig. 18.

In order to perform reliable analyses with this method, it is fundamental to have unambiguously defined, pre-set and known conditions of measurements. Only under those circumstances can the process of measurement data analysis be carried out and validated.

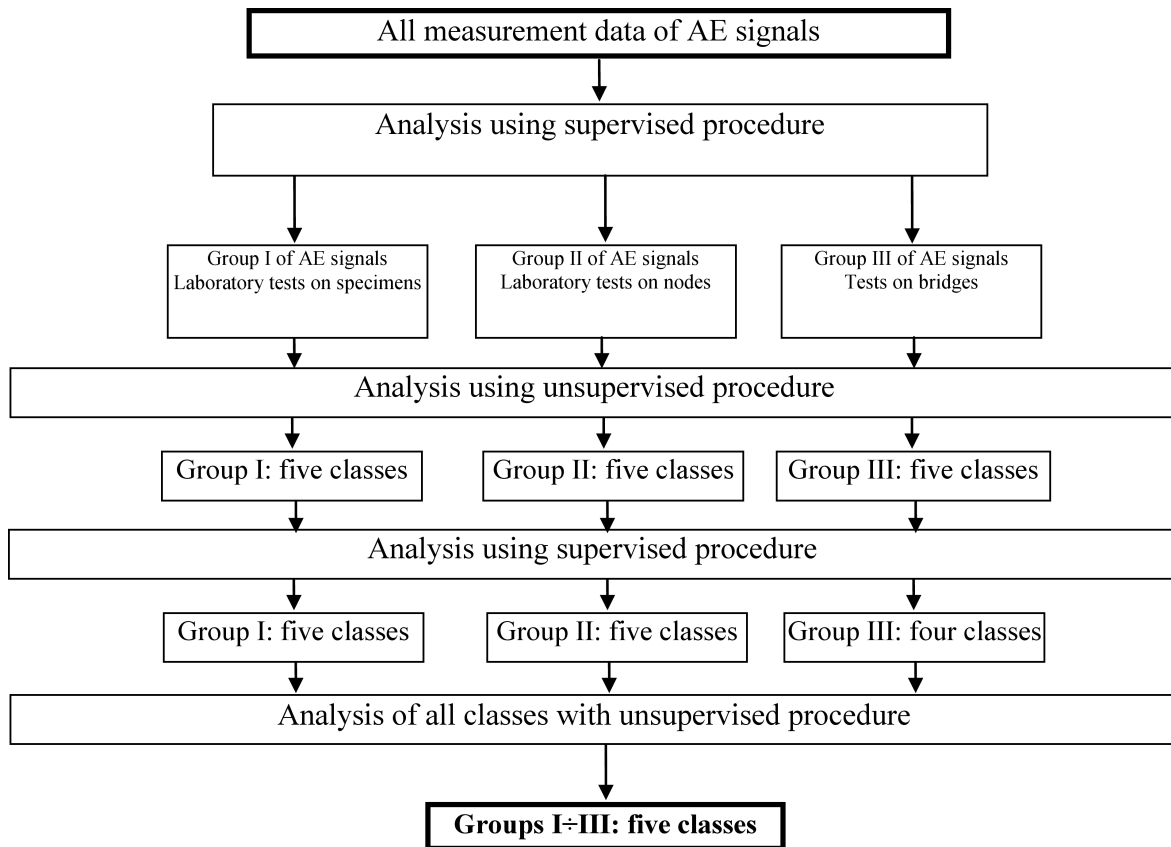

Fig. 18. Schematic representation of successive steps of the analysis

3.3. AE method application to composites. The AE method was also applied (by authors) to determine the beginning and the intensity of corrosive cracking of filaments in a loaded composite. In this case the waveforms of the acoustic wave, generated by various destructive processes, were analysed and compared.

It was found, due to microscopic observation, that three damage mechanisms can be observed during the load of an epoxy-glass composite [28–32]:

- cracking of the resin,
- fiber degradation,
- fiber breaking.

Experiments were performed on an epoxy-glass composite subjected to three-point bending in an alkaline environment. The test was carried out for constant displacement.

Three types of waves occurring in the process of corrosive cracking in an alkaline environment $Ca(OH)_2$ can be distinguished (Fig. 19a, b, c).

Signals of type “a” are the most common and include ca. 90% of all recorded acoustic signals. They are characterized by short rise time and short duration. The spectrum of the signal does not exceed 1 MHz, and the amplitude the rank of 45 dB. The signal reaches its highest value in the range of 200–250 kHz. An analysis of the course of the signal shows that it has relatively low amplitude recorded during

the process. It is assumed that such signal is generated due to the breaking of the epoxy matrix of the composite.

A second type, signal “b” is characterized by a higher amplitude reaching the level of 60 dB and the spectrum of up to 1.2 MHz. It has a longer rise time and duration of the signal than type “a”, which is probably due to the corrosive breaking of the fibres of the composite reinforcement. Its spectrum does not drop linearly but has local peaks. Corrosion in an alkaline environment does not run in a rapid way. Probably this is why the amplitude of the signal is so low. This type of signal includes about 5% of the registered signals.

The last 5% belong to the acoustic signal of type “c”. It substantially differs from the two previous ones. It is characterized by short rise time and long duration. The spectrum shows that the amplitude of the signals exceeds 60 dB and that they fill the entire spectrum. It can also be noticed that the signal reaches its maximum value in the range of 250–300 kHz. It is assumed that this type of signal is generated due to the breaking of fibres caused by extraction thereof from the composite due to high tensions occurring in the tested element.

It means that in the case of alkaline environment, three damage mechanisms due to load corrosion observed microscopically can be also identified using the analysis of the acoustic emission signal.

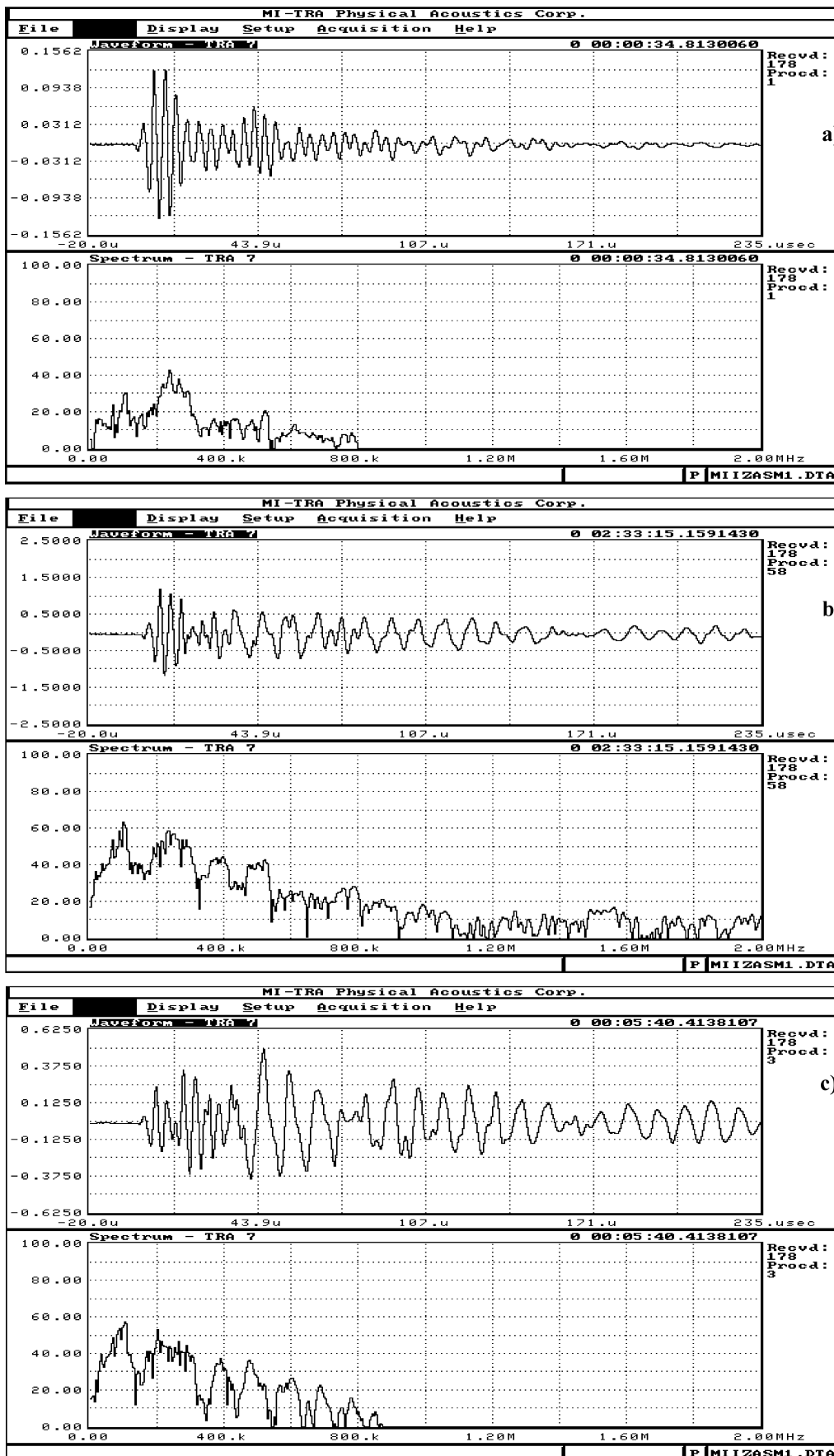

Fig. 19. Characteristics of a signal type "a", "b" and "c" for stress corrosion in an alkaline environment

4. Conclusions

The acoustic emission method presented in the paper, based on identification and location of active destructive processes generating AE signals, has been applied to monitor and evaluate over 70 real structures, mainly bridges. Tests were conducted for typical and excessive service load. The results of tests fully confirm that the monitoring of active destructive processes can provide basis for the diagnostics of the structures.

By applying AE method to monitor active destructive processes it is possible to:

- locate and identify active destructive processes in regular service,
- obtain factual and global identification and location (zonal accuracy) of active destructive processes,
- record destructive processes against timescale, to trace their growth and the size of areas affected by them,
- compile a database to identify the dynamics of active processes development in order to evaluate durability of a structure,
- identify sites that pose the greatest hazard to focus thorough non-destructive tests on them.

The method has also been successfully employed as well to detect corrosive and delamination processes in steel elements of chemical and petrochemical installations as to detect corrosive cracking in a loaded composite.

Acknowledgements. Research was executed under the development Project NR 04 0007 10 “Non destructive system of monitoring and diagnosis of reinforced concrete structures with particular emphasis on engineering objects”.

REFERENCES

- [1] K. Flaga, “Diagnostics, modernisation and rehabilitation of concrete bridges”, *Proc. 56 Scientific Conf.* 1, 123–156 (2010), (in Polish).
- [2] J. Bień, “Durability of bridges in European research projects”, *Proc. 56 Scientific Conf.* 1, 41–56 (2010), (in Polish).
- [3] M. Łagoda, “Development trends in diagnostics and monitoring of bridges in Europe” *Proc. 56 Scientific Conf.* 1, 291–300 (2010), (in Polish).
- [4] K. Ono, “Application of acoustic emission for structure diagnostic”, *Proc. 56 Scientific Conf.* 1, 291–300, 317–342 (2010).
- [5] A.M. Brandt, “On the durability of concrete structures”, *Proc. Int. Symp. CanMet’05 and Mindess Symposium* 1, 441 (2005).
- [6] A. Nair and C.S. Cai “Acoustic emission monitoring of bridges: review and case studies”, *Eng. Structures* 32, 1704–1714 (2010).
- [7] J. Hoła and K. Schabowicz, “Nondestructive diagnostic testing of building structures. Survey of selected state-of-art techniques with application examples” *Proc. 56 Scientific Conf.* 1, 189–206, (2010), (in Polish).
- [8] I.G. Main, M.C. Forde, and J. Halliady, “Acoustic emission on bridges: experiments on concrete beams”, *EWGAE 25th Eur. Conf. on Acoustic Emission Testing* 1, I/127–I/134 (2002).
- [9] M.J. Ing, S.A. Austin and R. Lyons, “Cover zone properties influencing acoustic emission due to corrosion”, *Cement and Concrete Research* 35 (2), CD-ROM (2005).
- [10] J. Hoła and K. Schabowicz, “Methodology of neural identification of strength of concrete”, *ACI Materials J.* 102 (6), CD-ROM (2005)
- [11] J. Hoła and K. Schabowicz, “Nondestructive elastic-wave tests of post-tensioned concrete girders in road bridge”, *17th World Conf. on Nondestructive Testing* 1, CD-ROM (2008).
- [12] S. Granger, A. Loukili, G. Pijaudier-Cabot, and G. Chanvillard, “Experimental characterization on the self-healing of cracks in an ultra high performance cementitious material: mechanical test and acoustic emission analysis”, *Cement and Concrete Research* 37, 519–527 (2007).
- [13] Ch.U. Grosse and F. Finck, “Quantitive evaluation of fracture processes in concrete using signal-based acoustic emission techniques”, *Cement and Concrete Research* 28, 284–295 (2006).
- [14] M.J. Ing, S.A. Austin, and R. Lyons, “Cover zone properties influencing acoustic emission due to corrosion”, *Cement and Concrete Research* 35 (2), CD-ROM (2005).
- [15] L. Gołaski, G. Świt, M. Kalicka, and K. Ono, “Acoustic non-destructive techniques as a new method for evaluation of damages in prestressed concrete structures: failure of concrete structures”, *J. Acoustic Emission* 24, 187–195 (2006).
- [16] G. Świt, “Diagnostic of prestressed concrete structures by means of acoustic emission”, *8th ICRM’S 2009, Proc. IEEE* 1, 958–962 (2009).
- [17] L. Gołaski, B. Goszczyńska, G. Świt, and W. Trąpczyński, “System for the global monitoring and evaluation of damage processes developing within concrete structures under service loads”, *Baltic J. Road and Bridge Eng.* 7 (4), 23–28 (2012).
- [18] G. Świt, W. Trąpczyński, and L. Płonecki, “Application of acoustic emission method for diagnosis of large dimensions machines”, *Mechanical Review* 10/11, 27–32 (2011), (in Polish).
- [19] G. Świt, *Analysis of the Destructive Processes in Bridge of Beams Prestressed with the Phenomenon of Acoustic Emission*, Kielce University of Technology, Kielce, 2011, (in Polish).
- [20] B. Goszczyńska, G. Świt, W. Trąpczyński, A. Krampikowska, J. Tworzewska, and P. Tworzewski, “Experimental validation of concrete crack identification and location with acoustic emission method”, *Archives of Civil and Mechanical Eng.* 12 (1), 23–28 (2012).
- [21] L. Gołaski, B. Goszczyńska, G. Świt, and W. Trąpczyński, *Method to Test and/or Monitor Damage Processes in the Steel Structures Subjected to Load*, Patent application no. 394641 (2011).
- [22] *Signal Processing and Pattern Recognition of AE Signatures. Experimental Analysis of Nano and Engineering Materials and Structures*, Springer, Amsterdam, 2007.
- [23] M. Nowak, I. Baran, J. Schmidt, and K. Ono, “Acoustic emission method for solving problems in double-bottom storage tanks”, *J. Acoustic Emission* 27, 153–158 (2009).
- [24] M. Nowak, I. Baran, J. Schmidt, and Z. Plochocki, “Application of acoustic emission in control of high-pressure pipe overstraining”, *Advanced Materials Research* 13–14, 153–158 (2006).
- [25] M. Nowak, I. Baran, and J. Schmidt, “Application of AE technique for detection of leakages in double-bottom structure of above-ground storage tank”, *48th AEWG Conf.* TX, CD-ROM (2005).

Monitoring of active destructive processes as a diagnostic tool for the structure technical state evaluation

- [26] A. Zagórski, W. Spychalski, and K.J. Kurzydłowski, "The use of non-destructive tests for detecting delamination arising in the petrochemical installations", *Protection against corrosion* 1, 9 (2008), (in Polish).
- [27] J. Płowiec, J. Szlagowska, K. Paradowski, G. Wojas, A. Zagórski, W. Spychalski, and K.J. Kurzydłowski, "Modern non-destructive test methods for evaluating the hydrogen degradation", *IV Int. Symp. Destruction of Materials and Constructions* 1, CD-ROM (2007), (in Polish).
- [28] A. Khennane and R.E. Melchers, "Meso-scale finite element model for environmental stress corrosion of GFRP", *Proc Fourth Australasian Congress on Applied Mechanics* 1, 573–578 (2005).
- [29] T.J. Myers, H.K. Kytömaa, and T.R. Smith, "Environmental stress-corrosion cracking of fiberglass: Lessons learned from failures in the chemical industry", *J. Hazardous Materials* 142 (3), 695–704 (2007).
- [30] G. Świt, "Evaluation of compliance change in concrete beams reinforced by GRP using AE", *J. Materials in Civil Eng.* 16 (5), 414–419 (2004).
- [31] G. Świt, "Durability of stressed E glass fibre in alkaline medium. Recent development in durability analysis of composite systems", *Proc. 4th Int. Conf. DURACOSYS'99* 1, CD-ROM (2000).
- [32] V. Pauchard, F. Grosjean, H. Campion-Boulharts, and A. Chateauminois, "Application of a stress-corrosion-cracking model to an analysis of the durability of glass/epoxy composites in wet environments", *Composites Science and Technology* 62, 493–498 (2002).