

# Identification and analysis of optimal method parameters of the V-block waviness measurements

S. ADAMCZAK, P. ZMARZŁY\* and K. STEPIEŃ

Faculty of Mechatronics and Mechanical Engineering, Kielce University of Technology,  
7 1000-lecia P. P. Ave., PL-25314 Kielce, Poland

**Abstract.** At the Kielce University of Technology, a new method of waviness measurement of cylindrical surfaces has been developed. The article deals with the research conducted to find the optimal V-block method parameters that can be used in a measuring device applied to waviness measurement of cylindrical surfaces. In order to keep high measuring accuracy of V-block method, all detectability coefficients which are function of V-block method parameters should not be negative. For this purpose computations were carried out in order to find such angular parameters that can be easily applied in measuring device and allow for obtaining positive detectability coefficients. Results of the study presented in this paper make it possible to modify the design of the measuring device. According to the authors, it will result in increasing the accuracy of V-block waviness measurement of cylindrical parts.

**Key words:** V-block method, waviness measurement, detectability coefficient.

## 1. Introduction

One of the most common groups of mechanical components are cylindrical parts. Such elements are used in various branches of industry, for instance in automotive, aerospace, and manufacturing engineering, as well as paper industry and power engineering. Since cylindrical elements usually fulfill responsible functions, their surface irregularities and mechanical properties should be precisely measured [1, 2]. An important problem of quality control and inspection of circular parts is the measurement of their roundness and waviness deviations. Several decades ago engineers did not pay attention to measuring this type of irregularities, because it was believed that they do not affect correct operation of the mechanisms. It is now clear that excessive values of roundness and waviness deviations of rotational parts cause vibration and noise [3]. Roundness contributes to function and performance of mechanical devices in many ways, including maintaining a lubricating film between mating components. It is particularly important in construction of diesel engines [4].

In many cases, the evaluation of cylindrical surface irregularities is limited to measuring roundness deviations in range 2–15 UPR (undulation per evolution) [5]. In the case of precision rotary mechanical components, such as rolling bearings, assessment limited to roundness deviations is insufficient. Therefore, surface irregularities of rotary parts should be examined in wider range of harmonic components, such as 16–50 UPR that represent waviness deviations [6, 7].

There are a few types of measuring devices that can be used to measure roundness and waviness deviations. These instru-

ments can also be used to measure cylindricity using different measuring strategy [8, 9]. Most of them are suitable for measuring form deviations of small cylindrical elements under laboratory conditions [10]. The growing demands of heavy industry require developing measuring methods that can be performed in-situ, for example, directly on machine tool. For such measurements the V-block method can be used.

The first person to conduct research related to the V-block method was a German scientist Georg von Berndt at the beginning of the twentieth century. Boerdijk used harmonic analysis based on trigonometric Fourier series for evaluation of roundness profile measured by the V-block method. An interesting measuring system was developed by Witzke [11]. The measuring device proposed consisted of two V-blocks and an inductive probe. Furthermore, Witzke also carried out computer simulations of the V-block angles. At that time research on the change of the sensor position relative to the axis of the V-block was carried out, which resulted in the introduction of non-symmetric three-point method. In consequence, a number of mathematical models used to complex analysis and to increase V-block method accuracy were developed. Interesting in-situ roundness measuring mechanism based on V-block method was described in [12]. The measuring device is composed of a V-block and an adaptive telescopic support and can be used to measure roundness deviation of crankshaft pin journals directly on grinding machine. Research work related with the application of the V-block method for roundness measurement was also carried out in USA [13].

Above mentioned research works have been related with the application of the V-block method to assess roundness measurement only, not to assess waviness, which is more difficult task. For this reason at the Kielce University of Technology a concept of an adaptation of the V-block method to waviness measurement of cylindrical parts has been developed [7, 14].

\*e-mail: pzmarzly@tu.kielce.pl

## 2. Methods of roundness and waviness measurement

The first measuring device used to measure roundness deviations was developed by R.E. Reason of Rank Taylor Hobson in the twentieth century. At this time, a radial change method known as the non-reference method was introduced. Currently, this method is widely used to evaluate form deviations of cylindrical surfaces. One of the easiest ways to measure roundness deviations using radial change method is by applying a bench center and a dial indicator (see Fig. 1).

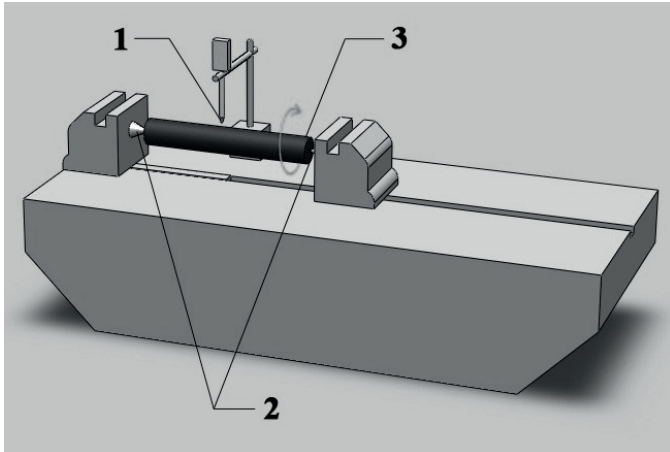

Fig. 1. Industrial method of roundness deviations assessment: 1 – dial indicator, 2 – centers, 3 – measured workpiece

In this method, the measured cylinder (3 in Fig. 1) is placed between centers (2) and it is rotating. Dial indicator (1) is located perpendicularly to the axis of the workpiece. The roundness measurement using bench center is quick and simple, hence it is widely used in industry. What is more, this measuring device is cheap. Applying a digital sensor and computer software allows for increasing the measuring accuracy of this method [15]. This method is simple, but measuring signal is affected by numerous factors such as spindle errors, etc. Therefore, it is limited to rough evaluation of roundness errors.

The most common measuring devices are those based on radial method and they are divided into two groups: rotary sensor and rotary table instruments. These types of measuring devices are of high measuring precision. Thanks to using the appropriate procedures to increase measurement accuracy, it is possible to obtain combined standard uncertainty of roundness deviations measurement equal to 1.3 nm [10]. Radial methods are commonly used under laboratory conditions.

Coordinate measuring machines can be applied to measure form deviations of cylindrical surfaces, too [16, 17] (see Fig. 2).

One of the main advantages of CMMs is their ability to conduct comprehensive measurements of the dimensions, as well as form errors and deviations of location. There are two methods of measuring roundness and waviness deviations using CMM. The first one is a continuous method using scanning probe, and the second is point-by-point measurement. Although CMMs can be applied to measure roundness deviations, their

measuring accuracy in comparison to the specialized measuring devices based on radial change method is much lower. An interesting solution in measuring large size cylinders on machine tool seems to be Coordinate Measuring Arms (CMAs) [18], nevertheless, the application of this method in waviness measurement is still limited.

The intensive development of computer tomography is the reason behind this measuring technology becoming more popular. Application of computed tomography X-ray 3D allows non-contact measurement of geometrical features inside the material, which was not possible previously [19]. The main drawbacks of 3D tomography are the limited size of the measured object and the high price of measuring instruments. Nevertheless, CT scans can be used to measure form deviation of inner holes located in imponderable places that cannot be measured by traditional methods.

For non-contact measurement of roundness deviations, air gauges can be used. The main advantage of air gauges is their ability to work under difficult conditions, but their application to the waviness measurement of cylindrical parts is still limited.

Measurement methods mentioned above are usually used to inspect roundness and waviness deviations of small size parts. Furthermore, those methods do not allow for in situ measurements of form deviations. In some branches of industry, it is not possible to measure parameters of cylindrical surface using radial instruments that usually work in laboratories. This is particularly important in such branches of industry as shipbuilding, textiles, and paper industry, because there are large and heavy cylindrical elements. In this case, measurement of roundness and waviness deviations should be carried out directly on the machine tool or on the operation stand [20].

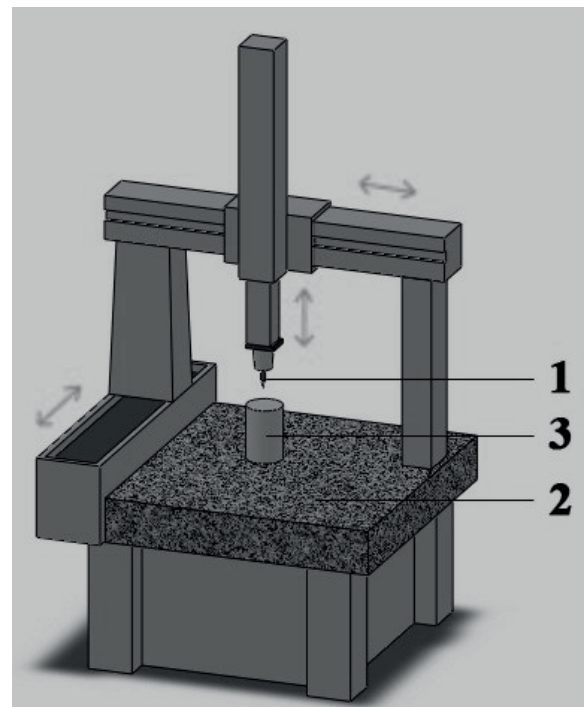

Fig. 2. Cylindricity measurement with the use of a coordinate measuring machine: 1 – measuring probe, 2 – measuring table, 3 – measured part

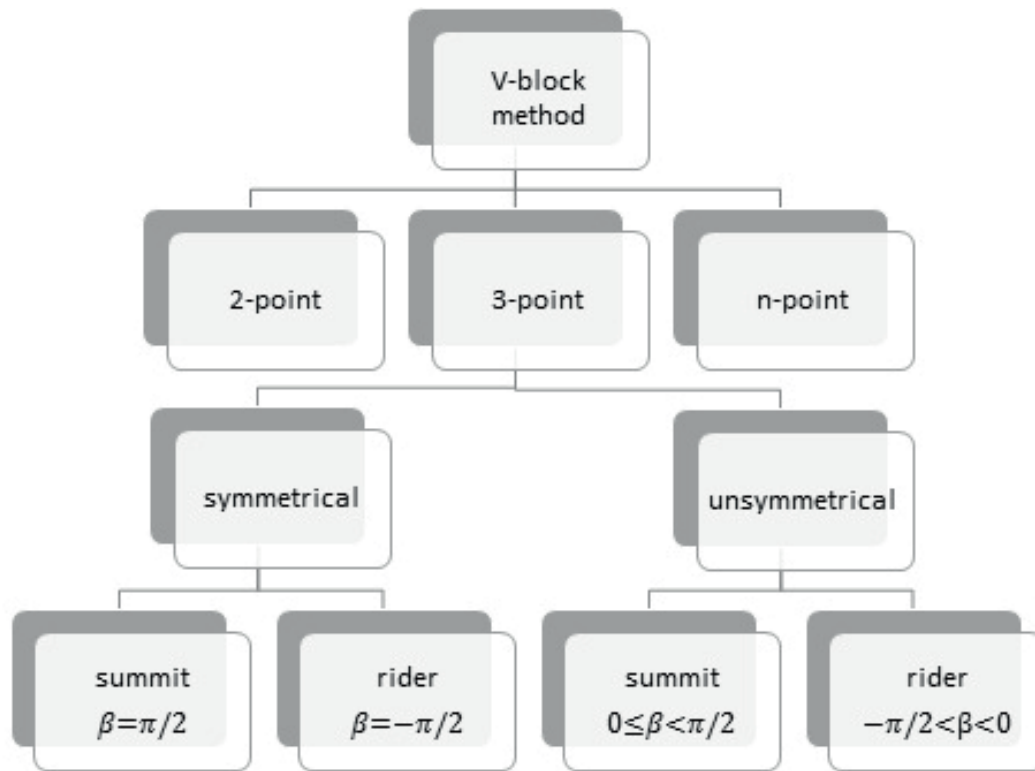

Fig. 3. The classification of V-block methods

Responding to the demands of heavy industry, the V-block method has been developed. Depending on the number and locations of measuring and base points, V-block methods can be classified as it is shown in Fig. 3.

The simplest way to implement the V-block method is to use a V-block and a dial gauge (see Fig. 4). Traditional V-block methods without measurement data processing have low measurement accuracy as sensor readings are quite different from the real profile. In order to increase measurement accuracy of the V-block method, a mathematical model was developed allowing for mathematical transformation of sensor readings into the signal approximately showing the values of the real profile [7, 14]. Next, this mathematical model was used in computer procedures eliminating the main errors of the V-block method, so that it can be used to evaluate roundness deviation and cylindricity. Based on this concept, numerous measuring devices used in industrial conditions were developed [20]. In most cases a design of measuring devices based on V-block methods is quite simple and in consequence relatively not expensive. Furthermore, measurement using V-block instrument does not require centering the workpiece on measuring table, as it is in radial methods. Therefore, measurements are simple to conduct and their time is relatively short.

The study of the literature revealed that there is a lack of solutions associated with the application of the V-block method to measure waviness deviations. This is why research has been initiated at The Kielce University of Technology, aiming at applying the V-block method to assess waviness deviations of machine parts.

### 3. The concept of the V-block waviness measurement

In the V-block method, the sensor readings are obtained in relation to base points. The base points comprise support points (A and B in Fig. 3) and a measurement point (C in Fig. 3). The location of these points in relation to the associated coordinate system is defined by V-block method parameters – angles  $\alpha$  and  $\beta$ . As we can see in Fig. 4, angle  $2\alpha$  defines tilt angle of the V-block and  $\beta$  is the angle between the direction of the axis of measuring sensor and the x-axis.

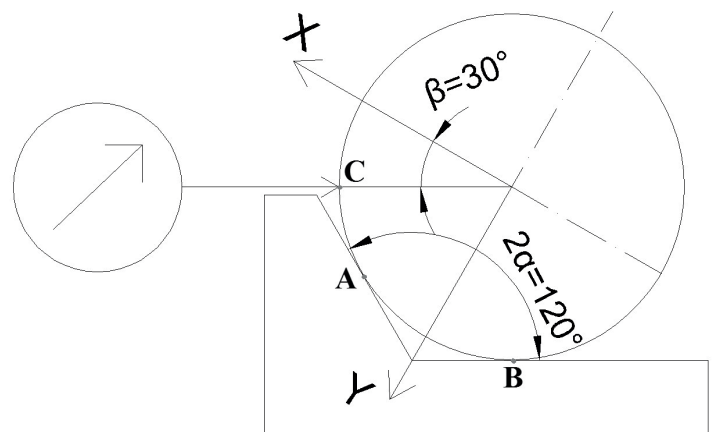

Fig. 4. V-block method parameters used in ROL-2

A characteristic feature of the V-block method is that the difference between maximum and minimum value obtained by measuring sensor  $\Delta F$  is different from the real deviation  $\Delta R$ . This is due to the fact that sensor readings depend not only on the values of deviation in contact point of measuring tip and surface of measured part (point C), but also on the values of deviations in support points A and B (see Fig. 3). In the past it was a significant limitation of V-block method application, because first, it was necessary to determine number of the predominant harmonic components and then calculate approximate values of roundness deviations using the following equation [7, 14]:

$$\Delta Z \cong \frac{1}{K_n} \Delta F, \quad (1)$$

where:  $\Delta F$  – deviation measured using sensor,  $K_n$  – the coefficient of detectability.

The detectability coefficient for each harmonic component of the profile can be described by general equation:

$$K_n(\alpha, \beta) = \frac{C_{Fn}}{C_{Rn}}, \quad (2)$$

where:  $C_{Fn}$  – amplitude for n-harmonic component of sensor readings  $F(\varphi)$ ,  $C_{Rn}$  – amplitude for n-harmonic component of real profile  $R(\varphi)$ .

If we assume that  $\hat{R}_n$  and be  $\hat{F}_n$  the n-components of expansion of profile  $R(\varphi)$  and  $F(\varphi)$  in an exponential Fourier series for  $n = -\infty, \dots, -1, 0, 1, \dots, \infty$ , then

$$R(\varphi) = \sum_{n=-\infty}^{\infty} \hat{R}_n e^{in\varphi}, \quad F(\varphi) = \sum_{n=-\infty}^{\infty} \hat{F}_n e^{in\varphi} \quad (3)$$

Then from Eq. (2) we have

$$\hat{K}_n = \frac{\hat{F}_n}{\hat{R}_n}. \quad (4)$$

Based on mathematical model presented in [7, 14] and performing expansion of the measured profile into an exponential Fourier series, detectability coefficient  $K_n$  can be defined using the following formula:

$$\hat{K}_n = e^{in\beta} - \frac{1}{2} e^{in\alpha} \left[ \frac{\cos\beta}{\cos\alpha} + \frac{\sin\beta}{\sin\alpha} \right], \quad (5)$$

$$-\frac{1}{2} (-1)^n e^{-in\alpha} \left[ -\frac{\cos\beta}{\cos\alpha} + \frac{\sin\beta}{\sin\alpha} \right]$$

where:  $\alpha$  and  $\beta$  – V-block method parameters.

As we can see in Eq. (5), values of angles  $\alpha$  and  $\beta$  are responsible for detecting particular harmonic of measured profile. Therefore, the selection of appropriate V-block method parameters is very important.

In order to increase accuracy of V-block waviness measurement, relevant computer procedures were developed. The procedures include values of detectability coefficients calculated by Eq. (5) and allow performing transformation of sensor readings  $F(\varphi)$  into a so-called reconstruction profile  $R_p(\varphi)$  that corresponds to the real profile  $R(\varphi)$ . Wider information related to the

mathematical model and computer procedures used to V-block waviness measurements was presented in works [7, 14].

Based on the assumptions presented, a model measuring stand used to V-block waviness measurements was developed at the Kielce University of Technology (see Fig. 5).

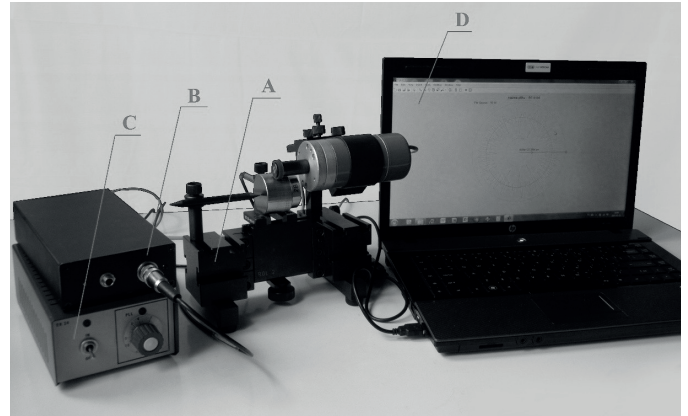

Fig. 5. The model measuring stand for V-block waviness measurement: A – measuring device ROL-2, B – measurement control system, C – drive unit, D – notebook equipment with transformation procedures

Measuring device ROL-2 has been designed and manufactured by Modra Company, but other components of model measuring stand including software have been developed at the Kielce University of Technology. The device can be used to measure waviness deviations of rolling bearing components. It is characterized by small size and compact design so it can be used directly in the work area under industrial conditions. Design of the device is based on following V-block method parameters:  $\alpha=60^\circ$ ,  $\beta=30^\circ$  (see Fig. 4).

In order to determine measurement accuracy of developed measuring system, experimental research was carried out. The experiment involved the measurement of waviness deviations of cylindrical workpieces using the ROL-2 and Talyround 365, which is a radial instrument. Based on comparative research, the V-block method accuracy was calculated. Experimental studies indicate that V-block method accuracy is equal to about 28.1% (for nominal V-block method parameters) and 22.4% (for real V-block method parameters) [14]. Calculation was carried out for a confidence level  $P = 0.95$ .

Analyzing Eq. (5), we can see that the values of detectability coefficients for specified range of harmonic components depend on the values of V-block method parameters. A disadvantage of application of the detectability coefficients in V-block method is fact, that for some combinations of angles  $\alpha$  and  $\beta$ , detectability coefficients are equal to zero. Then we cannot fully assess waviness profile, because not all harmonic components can be detected. Therefore, it is recommended to choose such combinations of method parameters for which detectability coefficients  $K_n$  in range  $n \in \langle 16, 50 \rangle$  are not equal zero.

As we can see in Fig. 4, the prism angle is  $2\alpha=120^\circ$ . Measuring sensor is located relative to the co-ordinate axis X at the angle  $\beta=30^\circ$ . Fig. 6 shows a bar chart of detectability coefficients  $K_{16}-K_{50}$  calculated for V-block method parameters  $\alpha=60^\circ$  and  $\beta=30^\circ$  applied in measuring device ROL-2.

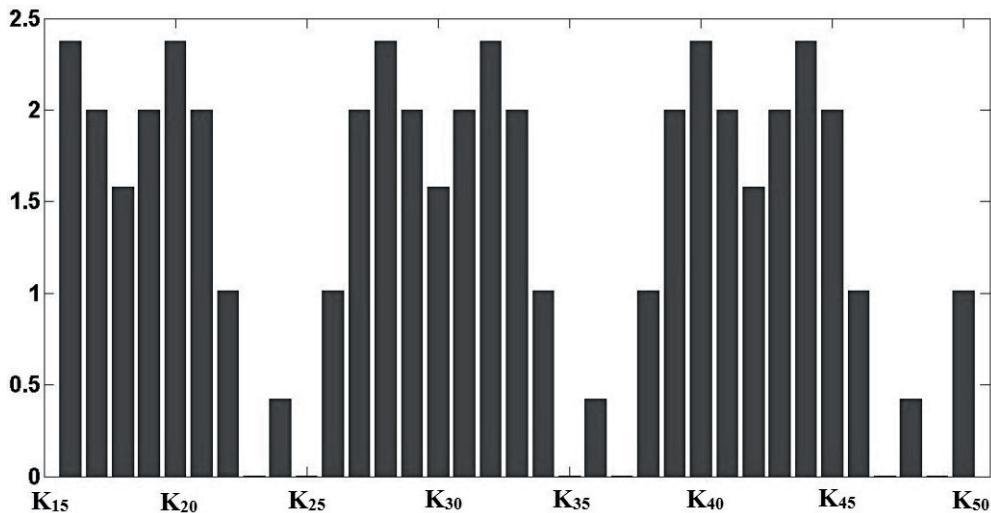

Fig. 6. The bar chart of detectability coefficients calculated for  $\alpha=60^\circ, \beta=30^\circ$

As we can see in Fig. 6, for combination of the angle  $\alpha=60^\circ, \beta=30^\circ$  some detectability coefficients are equal to zero ( $K_{23}, K_{25}, K_{35}, K_{37}, K_{47}, K_{49}$ ). In this case not all waviness components are detected, which reduces the V-block method accuracy.

Consequently, it was necessary to carry out computer simulations to obtain such combination of method parameters, for which detectability coefficients in range  $K_{16}-K_{50}$  are not equal zero and reach satisfactory values. Then, based on simulation result, it was possible to modify measuring device design to obtain a higher value of method accuracy.

#### 4. Computer simulations

In order to determine optimal V-block method parameters applied in ROL-2 used to measure waviness deviations of cylindrical, coefficients of detectability  $K_{16}-K_{50}$  were calculated for different V-block method parameters. Fig. 7 shows sensor location in the measuring device ROL-2.

Analyzing the design of ROL-2, we can conclude that the easiest way to change V-block method parameters is to modify the sensor mounting holder (4). This way it is possible to modify the positions of the sensor (1) in relation to the X-axis, which changes angle  $\beta$ .

Thus, calculations were performed for a constant angle  $\alpha = 60^\circ$  and the angle  $\beta$  changed in range from  $-90^\circ$  to  $90^\circ$ . In order to determine the appropriate V-block method parameters it is helpful to define some index, whose value would characterize the method quality. For this purpose the method quality rating  $W_j(6)$  has been developed, which is a harmonic average of the detectability coefficient  $K_n$  calculated in range  $n \in < 16, 50 >$ :

$$W_j(\alpha, \beta) = \frac{n_f - 15}{\sum_{n=16}^{n_f} \frac{1}{K_n}}, \quad (6)$$

where:  $n_f=50$ .

Application of a method quality indicator described by Eq. 6 allowed for excluding such combinations of the angles  $\alpha$  and  $\beta$ , for which even one detectability coefficient in range  $K_{16} - K_{50}$  is equal to zero, because  $W_j = 0$  in that case. Furthermore, high values of method quality indicator show that detectability coefficients calculated for selected angles  $\alpha$  and  $\beta$  are high, too. Fig. 8 shows bar chart of  $W_j$  indicators calculated for  $\alpha=60^\circ$  and  $\beta \in < -90^\circ, 90^\circ >$ .

Fig. 8 shows that there are many pairs of angles  $\alpha$  and  $\beta$  for which detectability coefficients are not equal to zero. The best result is obtained for angle  $\beta = 55^\circ$ , because  $W_j(60^\circ, 55^\circ) = 1.695$  then. However, due to technological reasons, applying these angles is difficult. As we can see in Figs. 4 and 7, in the measuring device the sensor is located in relation to the horizontal axis at the angle  $\beta = 30^\circ$ . In consequence, it is recommended

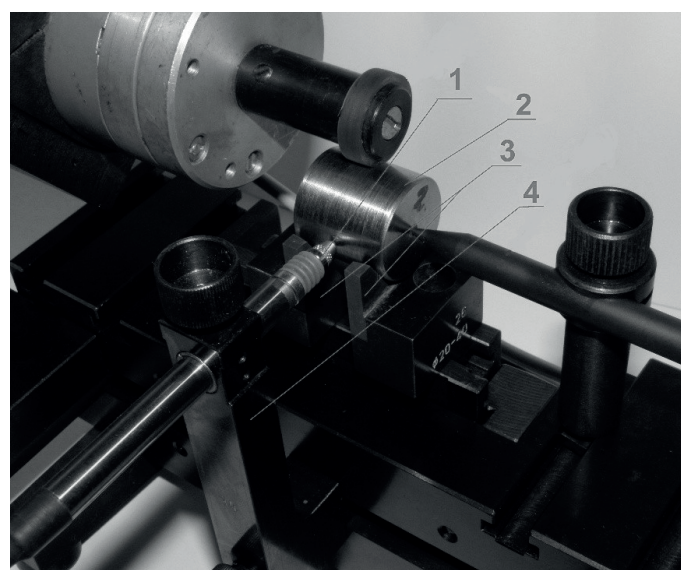

Fig. 7. Measuring device ROL-2: 1 – measuring sensor, 2 – workpiece, 3 – V-blocks, 4 – sensor holder

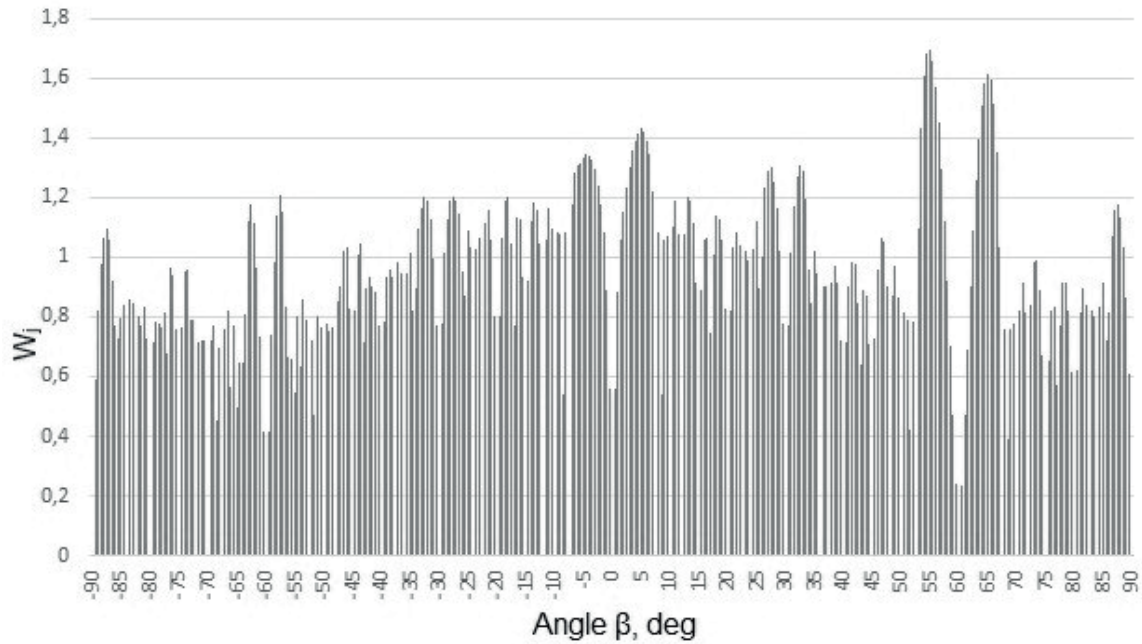

Fig. 8. The bar chart of method quality indicators  $W_j$  calculated for  $\alpha=60^\circ$ ,  $\beta \in \langle -90^\circ, 90^\circ \rangle$

to find such value of angle  $\beta$  that is approximately equal to the original value, in order to avoid significant change of the measuring device design. Hence, the scope of the simulation has been limited. Analyzing bar charts presented in Fig. 6, we can see that method quality indicators  $W_j$  calculated for angles  $\beta$  ranging from  $20^\circ$  to  $40^\circ$  achieve high values, too. These values are shown in Fig. 9.

Analyzing Fig. 9, we can conclude that it is proper to apply angles  $\beta$  lying within two intervals:  $\beta \in \langle 24.5^\circ, 29.5^\circ \rangle$  and  $\beta \in \langle 30.5^\circ, 35.5^\circ \rangle$ , because method quality indicators  $W_j$  are not equal to zero and reach high values then. It seems to be a good solution to apply  $\beta$  equal to  $33^\circ$ . In practice, it is not possible to manufacture a sensor holder, which would allow obtaining ideal value of angle  $\beta=33^\circ$ . However, as we can see in Fig. 9, if the

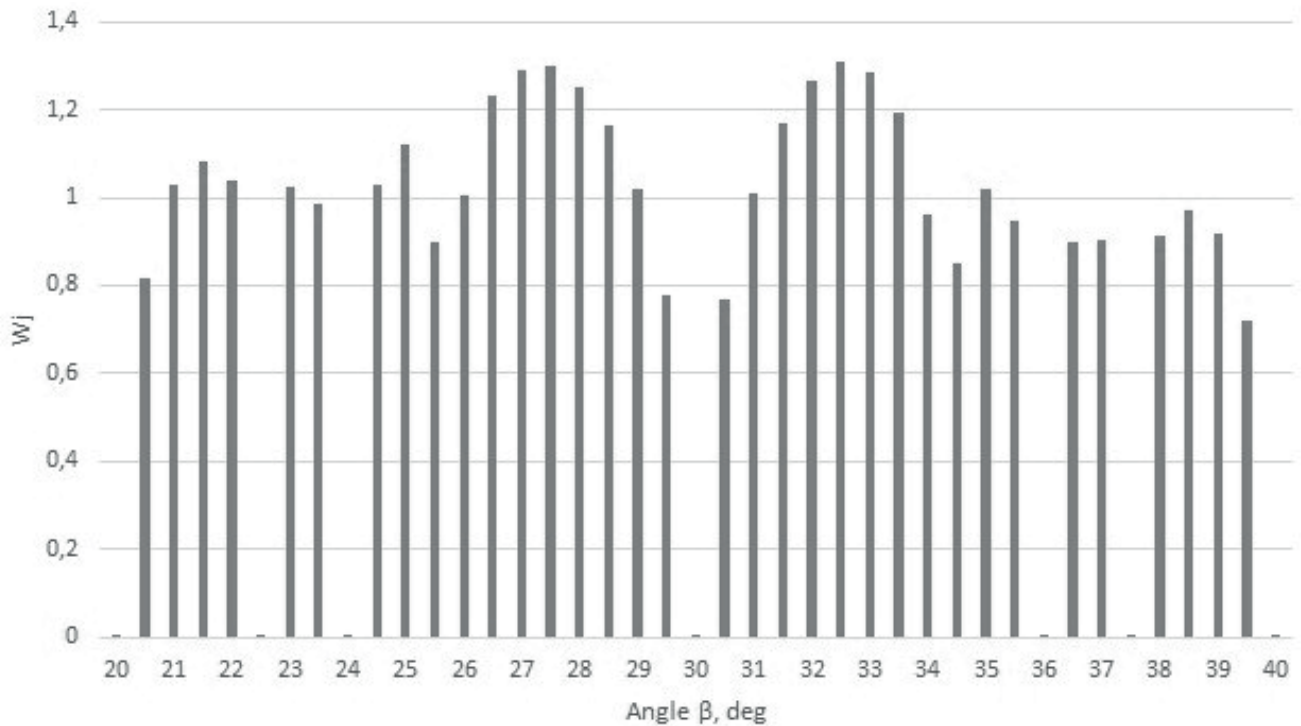

Fig. 9. The bar chart of method quality indicators  $W_j$  calculated for  $\alpha=60^\circ$ ,  $\beta \in \langle 20^\circ, 40^\circ \rangle$

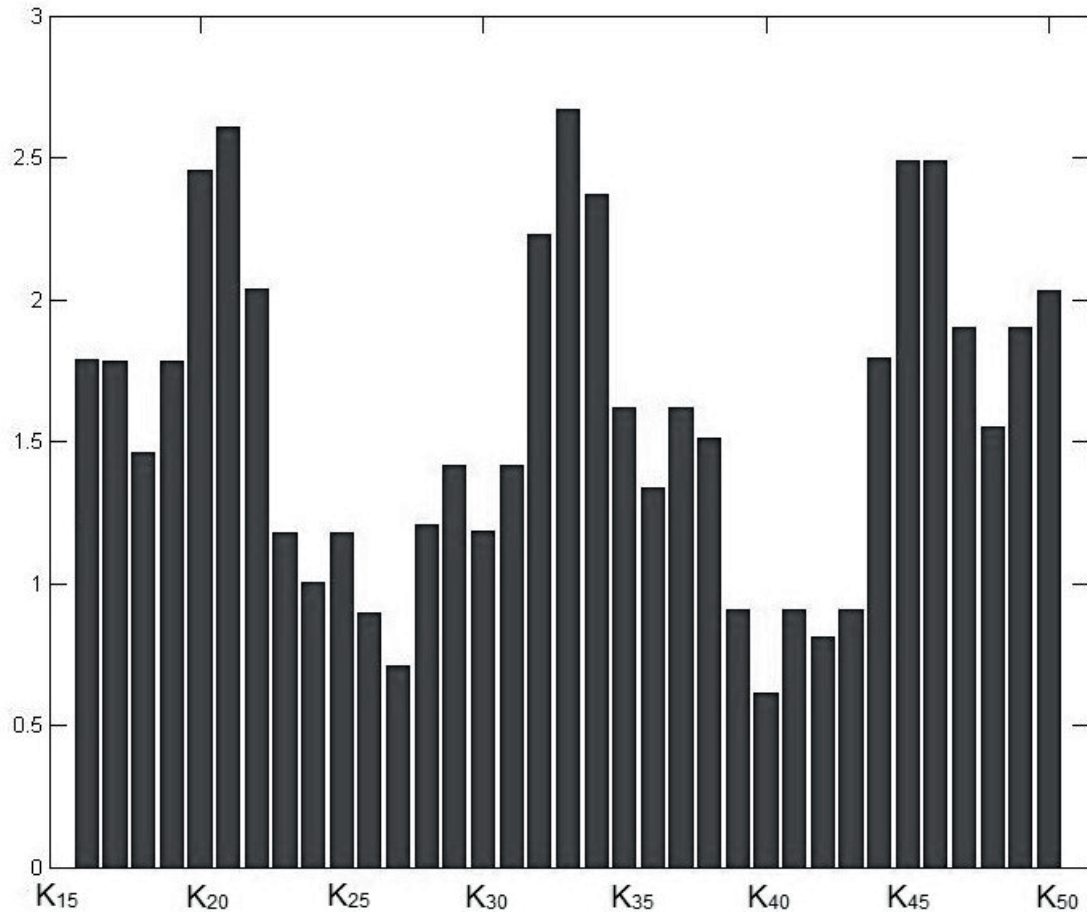

Fig. 10. The bar chart of detectability coefficients for  $\alpha = 60^\circ, \beta = 33^\circ$

real value of this angle differs from the nominal  $\pm 2.5^\circ$ , it will not be a reason of obtaining zero value of detectability coefficient. Accordingly, applying such V-block method parameters seems to be more relevant taking into account technological aspects of the device manufacturing. Fig. 10 shows a bar chart of detectability coefficients  $K_{16}$ – $K_{50}$  calculated for recommended V-block method parameters, i.e.,  $\alpha=60^\circ, \beta=33^\circ$ .

As it was to be expected, all coefficients of detectability  $K_n$  in range  $n \in \langle 16, 50 \rangle$  are positive and reach values above 0.5. Thus, the combination of angles  $\alpha=60^\circ, \beta=33^\circ$  permits detection of all harmonic components from the range 16–50.

## 5. Summary and conclusions

Nowadays, intensive development of mechanical technology requires a comprehensive analysis of surface geometrical structure. In some cases the measurement of the roundness deviations is not sufficient to analyze surface irregularities of investigated elements. Therefore, surface geometrical structure of cylindrical parts should be analyzed in a wider range of harmonic components, including waviness.

Most measuring devices allow for performing laboratory measurements. However, in heavy industry, i.e. power industry, papermaking and shipbuilding, there are large-size

cylindrical parts that cannot be transported to the laboratory due to their dimensions and weight. Thus, such machine parts can be measured directly on the factory floor or on a machine tool. Such measurements can be carried out with the use of the V-block method.

The main goal of research presented in this paper was to obtain such V-block method parameters for whose detectability coefficients  $K_n$  in range  $n \in \langle 16, 50 \rangle$  are not equal zero, which would allow detecting all waviness components of profiles. Additionally, it was necessary to choose only such combination of V-block method parameters that can be applied in the measuring device ROL-2. Simulation results show that the combination  $\alpha=60^\circ$  and  $\beta=33^\circ$  is recommended for this purpose. The angle  $\beta=33^\circ$  can be easily applied in a measuring system, because it only requires slight modification of the design of the system. Furthermore, research results provide a variety of other method parameters that can be used to measure waviness deviations of cylindrical parts.

Research results reveal that the measurement accuracy of the V-block method used to measure waviness deviation of cylindrical parts depends on values of V-block method parameters. In consequence, the selection of appropriate V-block method parameters is very important during the process of designing and manufacturing of instruments based on this measurement method.

The aim of further study in the research area of this paper will be a modification of the design of the device ROL-2 that will allow for using the combination of angles  $\alpha=60^\circ$  and  $\beta=33^\circ$  during measurements. Then, an experimental study will be conducted aiming at determination of the evaluation of measurement accuracy. According to the authors, the modification of the design of the instrument should result in increasing the accuracy of the method.

## REFERENCES

- [1] A. Zawada-Tomkiewicz and J. Ściegienka, "Monitoring of a micro-smoothing process with the use of machined surface images", *Metrology and Measurement Systems* 18 (3), 419–428 (2011).
- [2] S. Adamczak, J. Bochnia and Cz. Kundera, "Stress and strain measurements in static tensile tests", *Metrology and Measurement Systems* 19 (3), 531–540 (2012).
- [3] M.D. Bryant, A. Tewari and D. York, "Effects of micro (rocking) vibrations and surface waviness on wear and wear debris", *Wear* 216, 60–69 (1997).
- [4] A. Bąkowski and L. Radziszewski, "Determining selected diesel engine combustion descriptors based on the analysis of the coefficient of variation of in-chamber pressure", *Bull. Pol. Ac.: Tech.* 63(2), 457–464 (2015).
- [5] B. Gapiński and M. Wiczorowski, "Measurement of Diameter and Roundness on Incomplete Outline of Element with Three-Lobbing Deviation", *24th DAAAM International Symposium On Intelligent Manufacturing And Automation, 2013, Book Series: Procedia Engineering* 69, 247–254 (2014).
- [6] S. H. R. Ali, "The influence of strategic parameters on roundness accuracy development", *11th IMEKO TC14 International Symposium on Measurement and Quality Control. Cracow, Poland, September 2013*, 287–297 (2013).
- [7] S. Adamczak, P. Zmarzły and D. Janecki, "Theoretical and practical investigations of V-block waviness measurement of cylindrical parts", *Metrology and Measurement Systems* 22 (2), 181–192 (2015).
- [8] D. Janecki, J. Zwierzchowski and L. Cedro, "A problem of optimal cylindricity profile matching", *Bull. Pol. Ac.: Tech.* 63(3), 771–779 (2015).
- [9] D. Janecki and J. Zwierzchowski, "A method for determining the median line of measured cylindrical and conical surfaces", *Meas. Sci. Technol.* 26, 1–9 (2015).
- [10] R. Thalmann and J. Spiller, "A primary roundness measuring machine", *Recent Developments in Traceable Dimensional Measurements III, Proceedings SPIE* 5879, 1–10 (2005).
- [11] F. W. Witzke, "In situ out-of-roundness measurement", *Proceeding of the Institution of Mechanical Engineering* 182 (3), 430–437 (1968).
- [12] H. Yu, M. Xu and J. Zhao, "In-situ roundness measurement and correction for pin journals in oscillating grinding machines", *Mechanical Systems and Signal Processing* 50–51, 548–562 (2015).
- [13] B. Muralikrishnan, S. Venkatachalam, J. Raja and M. Malburg, "Note on the three-point method for roundness measurement", *Precision Engineering* 29, 257–260 (2005).
- [14] S. Adamczak, P. Zmarzły and K. Stępień, "Assessment of an influence of real values of V-block method parameters on the method accuracy of V-block waviness measurement of rotary machine parts", *Solid State Phenomena* 237, 112–117 (2015).
- [15] A. Janusiewicz, S. Adamczak, W. Makiela and K. Stępień, "Determining the theoretical method error during an on-machine roundness measurement", *Measurement* 44, 1761–1767 (2011).
- [16] L. Ocnasova, B. Gapinski, R. Cep, L. Gregova, B. Barisic, J. Novakova and L. Petrkovska, "Roundness Deviation Measuring Strategy at Coordination Measuring Machines and Conventional Machines", *World Academy of Science, Engineering and Technology* 32, 523–526 (2009).
- [17] M. Poniatowska, "Research on spatial interrelations of geometric deviations determined in coordinate measurements of free-form surfaces". *Metrology and Measurement Systems* 16 (3), 501–510 (2009).
- [18] J. Sładek, K. Ostrowska and A. Gąska, "Modeling and identification of errors of coordinate measuring arms with use of metrological model", *Measurement* 46, 667–679 (2013).
- [19] B. Gapiński, M. Wiczorowski, L. Marciniak-Podsadna, B. Dybala and G. Ziolkowski, "Comparison of Different Method of Measurement Geometry using CMM, Optical Scanner and Computed Tomography 3D", *Procedia Engineering* 69, 255–262 (2014).
- [20] K. Nozdzykowski and D. Janecki, "Comparative studies of reference measurements of cylindrical profiles of large machine components", *Metrology and Measurement Systems* 21 (1), 67–76 (2014).