



ARCHIVES
of
FOUNDRY ENGINEERING

DOI: 10.1515/afe-2017-0127

Published quarterly as the organ of the Foundry Commission of the Polish Academy of Sciences

ISSN (2299-2944)
Volume 17
Issue 4/2017

35 – 42

Taguchi Approach for Optimization of Parameters that Effect Grain Size of Cast A357 Alloy

M. Çolak^{a*}, D. Dışınar^b^a Bayburt University, Faculty of Engineering, Mechanical Engineering Department, 69000, Bayburt, Turkey^b Istanbul University, Faculty of Engineering, Metallurgy and Materials Science Engineering Department, 34320, İstanbul, Turkey

*Corresponding author. E-mail address: mcolak@bayburt.edu.tr

Received 10.04.2017; accepted in revised form 14.06.2017

Abstract

Grain refining and modification are common foundry practice for improving properties of cast Al-Si alloys. In general, these types of treatments provide better fluidity, decreased porosity, higher yield strength and ductility. However, in practice, there are still some discrepancies on the reproducibility of the results from grain refining and effect of the refiner's additions. Several factors include the fading effect of grain refinement and modifiers, inhomogeneous dendritic structure and non-uniform eutectic modification. In this study, standard ALCAN test was used by considering Taguchi's experimental design techniques to evaluate grain refinement and modification efficiency. The effects of five casting parameters on the grain size have been investigated for A357 casting alloy. The results showed that the addition of the grain refiner was the most effective factor on the grain size. It was found that holding time, casting temperature, alloy type and modification with Sr were less effective over grain refinement.

Keywords: A357, Grain refinement, Modification, Taguchi, Optimization

1. Introduction

In the solidification process, mechanical properties, grain size and shape are directly affected by casting method in the production of parts. Therefore, the basis and control of the solidification microstructure are greatly important in enhancing the quality of castings structure. Also, as a result of the fact that solidification in casting microstructure is effective for service life of the parts, thus, solidification must be very well controlled in order to achieve the desired properties. In the casting of aluminum alloys, grain refinement and modification treatments are widely used [1]. In the unmodified alloys, the casting microstructure is

composed of elongated and irregular dendritic structure. This heterogeneity leads to decreased mechanical properties. By using grain refinement, homogeneous, regular and equiaxed dendritic structure is obtained whereas segregation is also reduced which has a significant impact on the mechanical properties of castings [2, 3].

Aluminum master alloys that are used for grain refinement contains different amounts of either Ti and B or only B which are commercially available. Grain refined aluminum castings exhibits high fluidity and feeding, improved tensile and fatigue strength, and low micro porosity [4, 5, 6, 7, 8, 9, 10]. The addition of titanium (Ti) and boron (B) into liquid aluminum in a small amount is known to have a sudden and significant effect on grain

refinement [1, 2, 3, 4, 5, 11, 12]. The mechanism of grain refinement [13] states that the intermetallic compounds which are Al_3Ti , TiB_2 and AlB_2 [14] make heterogeneous nucleation centers that lead to obtaining of finer grains [5, 6, 7, 13, 14, 15, 16].

Commercial Al-Ti-B master alloys of rod-shaped are widely used in 5Ti%-1B%-Al combination and generally named as Al5Ti1B grain refiners. The amount of addition of these master alloys vary from 1/1000 to 5/1000 which depends on grain refining method, cooling rate, chemical composition, scrap level etc [1, 2, 4]. After the addition of grain refiner to the melt, it homogenizes in a short time, but this effect decreases by increased holding time [10, 17]. This is known as the fading effect and this depends on many factors. The most important one of them is the density difference that leads to sedimentation of inoculant particles. Another important parameter is the solubility limit of $TiAl_3$ phase where the limits of α -phase is up to 0.15 wt % Ti. Above this level, peritectic reaction leads to formation and presence of $TiAl_3$ intermetallic which is not required in the matrix [18].

In addition to the achievement of improved properties by grain refinement, Sr, Na and Sb are widely used for the modification process in the casting of Al-Si alloy. Silicon particles in the eutectic structure are lamellar which is transformed into finer fibrous structure [19, 20, 21, 22, 23, 24]. Fluidity and feedability is increased particularly by the depression of eutectic temperature [25]. Nielsen [26] designed a system to measure the feedability of aluminum alloys. Permeability of dendritic mesh is measured. Two zone furnace is used where the flow of liquid metal through the solidifying region is controlled until the feeding is stopped [27].

Casting of aluminum alloys by grain refining and modifying master alloy additions in the light of better feeding ability, less porous structure, high tensile strength and increased elongation have some differences in implementation in foundries and processes need to be controlled carefully. Therefore, it is required that the effect of factors that affect the grain size should be determined. The aim of this study was targeted to determine the

factors that likely to affect the grain size of A357 aluminum alloy. For this reason, parameters were selected as: grain refining addition, holding time, modifier addition, molding temperature and alloy type (primary/secondary). Taguchi experimental design method was used to optimize the test conditions.

2. Material and Method

2.1. Casting Procedure

A357 alloy was melted in an electrical resistance furnace. The chemical compositions of the primary and secondary scrap ingots are given in Table 1.

Table 1.

A357 alloy chemical composition (wt%)

Alloy Type	Chemical Composition %						
	Al	Si	Mn	Mg	Fe	Cu	Ti
Primary	91,33	7,48	0,32	0,29	0,162	0,003	0,018
Secondary	91,45	7,23	0,31	0,30	0,171	0,002	0,132

Melting temperature was selected as 750°C and degassing was carried out by using porous graphite where nitrogen was purged for 15 minutes. For the grain refining, 0.2% Ti including Al-5Ti-1B master alloy was used; and for modification, 0.02% Sr from Al-% 10Sr master alloy was added. The liquid metal was poured into the cone made from 5 mm sheet steel as shown in Figure 1.a where the dimensions was in accordance with ALCAN standards. A portion of 25 mm from the mold base was solidified via immersing in water content as shown schematically in Figure 1.b.

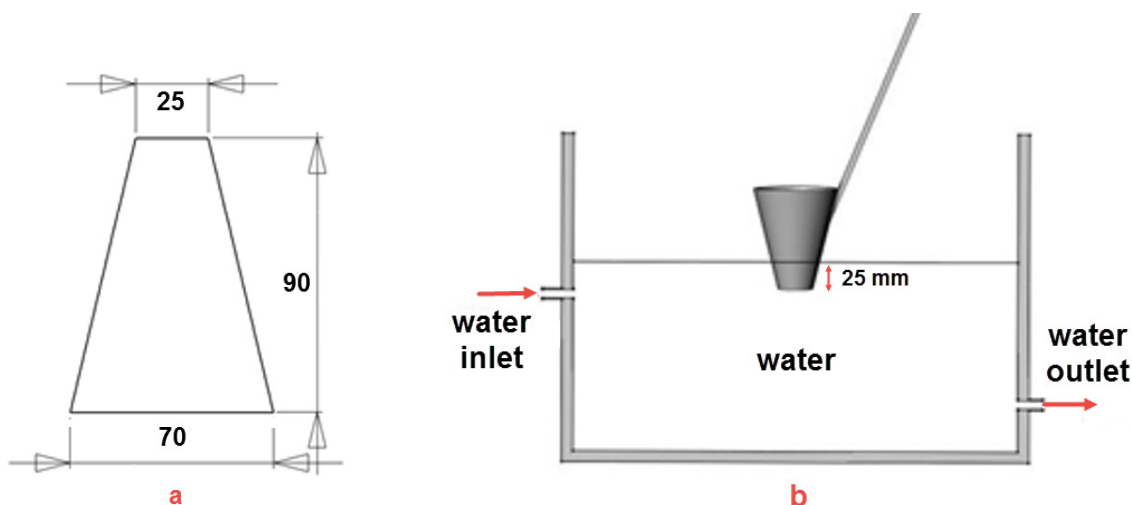

Fig. 1. Dimensions of the test specimen, b) A schematic representation of the solidification apparatus

In Figure 2.a, a photograph of the samples obtained after solidification and cooling are illustrated. In the experiments, in order to prevent the liquid aluminum reaction with the steel mold, the mold was coated with boron nitride (BN). Once the samples



were solidified, they were sectioned as shown in Figure 2 from the base by 25 mm and subjected to grain size measurements. Metallographic samples were prepared and then etched in Paulton solution (60% HCl, 30% HNO₃, 5%HF, 5%H₂O).

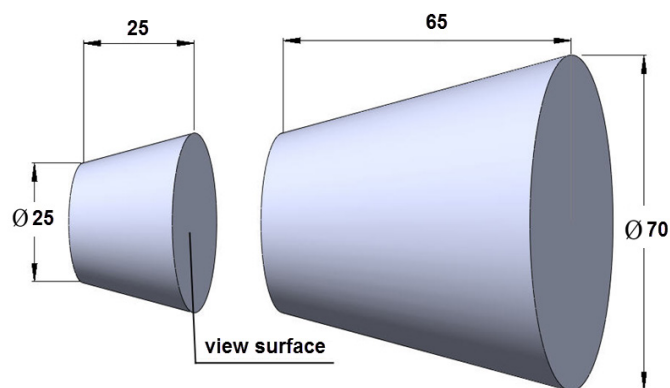

Fig. 2. a) The test specimen, b) ALCAN test specimen dimensions and views of the surface

Microscopic examination and grain size measurements were carried out in light microscope Nikon Eclipse L150 and image analysis was performed using Clemex Vision Lite image analysis software. The average grain size of each sample was recorded from the values obtained by the software.

2.2. Experimental Design

Taguchi's method is known to be used for optimizing parameters to eliminate any variations that need to be investigated. In the end, product quality is aimed to be achieved by a design of minimum number of experiments.

In this study, Taguchi's approach was used based on the five factors which are summarized in Table 2. As seen in Figure 3, the mixed L8 (27) orthogonal array has been selected [28, 29]. First column was assigned to holding time (factor A); second column to alloy type (factor B), third column was grain refinement master alloy addition (factor C); fourth column was modifier (factor D); and the last column was set to casting temperature (factor E).

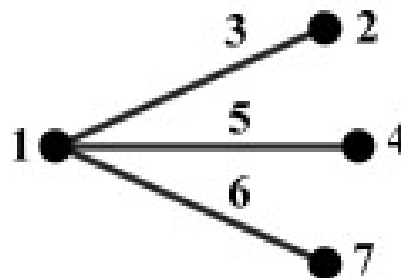

Fig. 3. Linear graphs for L8 array [28]

Table 2.

Control factors and their levels

Control factors	Levels				Units
	I	II	III	IV	
A: Holding Time	5	15	30	60	min
B: Alloy type	Primary	Secondary	-	-	-
C: Addition of grain refining master alloy	Yes	No	-	-	0.2% Ti
D: Addition of modifier master alloy	Yes	No	-	-	0.02% Sr
E: Casting temperature	700	750	-	-	°C

3. Results and Discussions

3.1. Analysis of Control Factors

Minitab 16.0 software was used to analyze each control factor (A, B, C, D and E) on the grain refinement of A357 alloy. Signal to Noise ratios are given in Table 3. S/N response and related mean response is given in Table 4 and 5 respectively.

Table 3.
Experimental design for grain size using mixed L8 orthogonal array

Holding Time	Alloy type	Addition of grain refining alloy	Addition of modifier alloy	Casting temperature	Grain size	S/N ratios
5	Primary	✓	✓	700	245	-47.78
5	Secondary	✗	✗	750	680	-56.65
15	Primary	✓	✗	750	200	-46.02
15	Secondary	✗	✓	700	710	-57.03
30	Primary	✗	✓	750	765	-57.67
30	Secondary	✓	✗	700	185	-45.34
60	Primary	✗	✗	700	780	-57.84
60	Secondary	✓	✓	750	250	-47.96

The strongest influence according to the control factor was determined by checking the highest difference.

It was found that addition of grain refining (C) was the dominant factor.

Table 4.
S/N response table for the grain size.

Level	A	B	C	D	E
1	-52.22	-52.33	-46.78	-51.46	-52.08
2	-51.52	-51.74	-57.30	-52.61	-52.00
3	-51.51				
4	-52.90				
Delta	1.39	0.59	10.52	1.15	0.08
Rank	2	4	1	3	5

Table 5.
Means response table for the grain size

Level	A	B	C	D	E
1	462.5	497.5	220.0	461.3	473.8
2	455.0	456.3	733.8	492.5	480.0
3	475.0				
4	515.0				
Delta	60.0	41.3	513.8	31.3	6.3
Rank	2	3	1	4	5

Figure 4 shows the main effects of S/N ratios for the grain size. From these plots, according to the shift in levels, optimum test condition can be determined. As seen in Figure 5, the respective

levels of $A_3B_2C_1D_2E_1$ show the grain size difference. It is evident that addition of grain refiner (factor C) has the most significant effect.

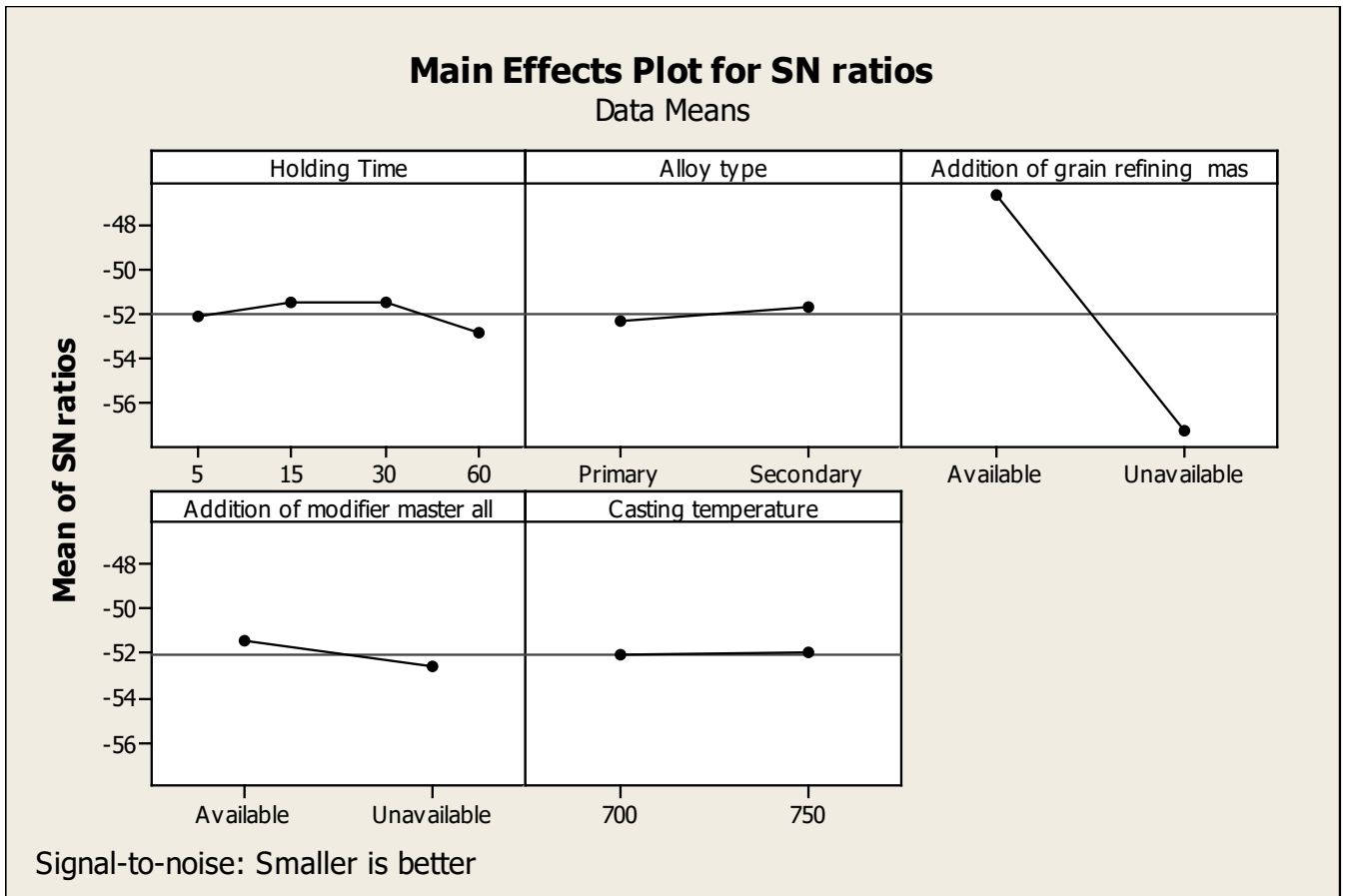

Fig. 4. Effect of control factors on grain size

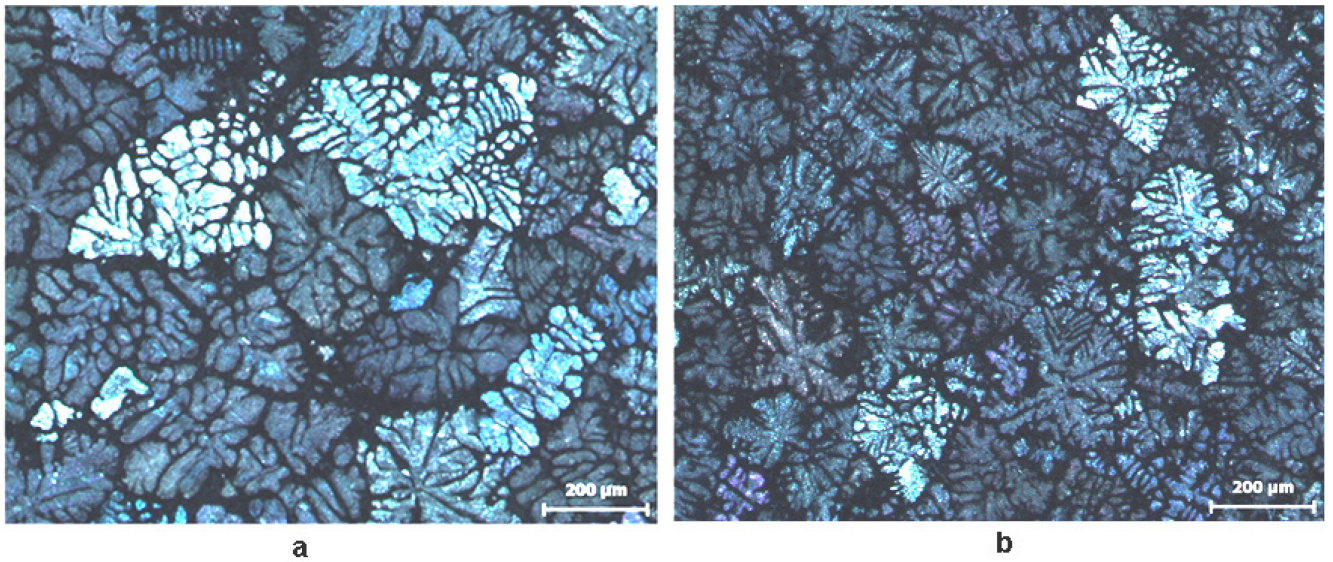

Fig. 5. Micrograph pictures; a) 1. Experiment samples, b) Best grain size sample

3.2. Analysis of Variance

ANOVA was performed to determine the statistical analysis by using the following equations [30]:

$$SDQ_T = \left[\sum_{i=1}^N (S/N)i^2 \right] - \frac{T^2}{N} \quad (1)$$

$$SDQ_A = \left[\sum_{i=1}^{K_A} \left(\frac{A_i^2}{n_{Ai}} \right) \right] - \frac{T^2}{N} \quad (2)$$

$$DOF_{total} = N - 1 \quad (3)$$

$$V_{factor} = \frac{SS_{factor}}{DOF_{factor}} \quad (4)$$

$$F_{factor} = \frac{V_{factor}}{V_{error}} \quad (5)$$

$$P_{factor} = \frac{SDQ_{factor}}{SDQ_{total}} \quad (6)$$

SS_T : sum of squares of total variation,

N : total number of experiments,

SS_A : sum of squares of factor A,

K_A : number of levels for factor A,

A_i : sum of the total i th level of the factor A,

n_{Ai} : number of specimens for i th level of factor A,

T : sum of total (S/N) ratio of the experiments,

DOF : degrees of freedom,

V_{factor} : variance of the factor,

SS_{factor} : sum of squares of the factor,

F_{factor} : F ratio of the factor.

Percentage of contribution (P%) from ANOVA analysis gives the degree of influence of the parameter. An 'FTest' values of lower than '5%' is considered to be statistically and physically insignificant. Table 6 shows that the ANOVA for grain size.

Table 6.
ANOVA tables for grain size

Source	DF	SDQ	Variance	F_{test}	F_{table}	P^a (%)
A	3	4284	4284	1428	7.85 ^b	0.79
B	1	3403	3403	3403	12.28 ^b	0.63
C	1	527878	527878	527878	12.28 ^b	98.19
D	1	1953	1953	1953	12.28 ^b	0.36
E	1	pooled	pooled	pooled	pooled	pooled
Error	1	78	78	78		
Total	7	537597				

SDQ: sum of squares; DF: degrees of freedom; P : percentage of contribution

^apercentage of contribution.

^b99% confidence level.

From Table 6, one can observe that holding time (A) ($P=0.79\%$), alloy type (B) ($P=0.63\%$), addition of grain refining master alloy (C) ($P=98.19\%$) and addition of modifier master alloy (D) ($P=0.36\%$) has the significant effect on the grain size. The factors A, B, D and E do not contribute to grain refinement.

3.3. Confirmation Tests

In this study, five different parameters were selected to be investigated by Taguchi method (L8). Effect of holding time, alloy type, addition of grain refining master alloy and addition of modifier master alloy on the grain size was evaluated. Comparison of S/N ratio and ANOVA resulted in similar findings. A3B2C1D1 condition was found to be the optimal conditions for grain refinement.

The confirmation tests suggested that Taguchi's orthogonal design was successfully applied to grain refinement of A356 alloy. For reduced grain size, optimum combination of process parameters was A3 B2 C1 D1 condition, referring to the holding time of 30 min (A3), secondary of alloy type (B2), addition of grain refining master alloy of unavailable (C1) and addition of modifier master alloy of unavailable (D1). The comparison of prediction and experimental results is given in Table 7. It can be seen that the difference is only about 0.05% which can be considered to be insignificant.

Table 7.
Results of the confirmation experiments for grain size

Level	Optimal control parameters	
	Prediction	Experimental
A ₃ B ₂ C ₁ D ₁	A ₃ B ₂ C ₁ D ₁	A ₃ B ₂ C ₁ D ₁
S/N ratio for grain size (dB)	-45.32	-45.34

4. Conclusions

The effect of holding time, casting temperature, alloy type, modification and grain refinement addition over the grain size of A357 alloy was investigated by means of using Taguchi approach. The experimental findings were used on Minitab and ANOVA statistical analysis revealed that addition of Al5Ti1B about 0.2 wt% levels to A357 had the most significant influence on grain refinement. On the other hand, casting temperature from 700 to 750°C had no particular effect over the grain refinement. Similarly, Sr modification had no influence as well.

The lowest grain size was measured in the secondary alloy that was melted at 700°C which was held for 30 minutes which was 185 µm. On the other hand, the largest grain sizes were found in the tests with the primary alloy after prolonged holding times which varied from 30 to 60 minutes and results in 710 and 780 µm average grain size.

The reason behind the obtaining of smaller grain with secondary alloy due to the fact that that alloy had already contained 0.132 wt% Ti. Thus, with the additional Al5Ti1B addition, even after 60 minutes of holding, the fading effect was not observed. It is important to note that when extra Ti was not added to secondary alloy, grain size was increased after 5 minutes of holding.

References

- [1] Bryant, M., Fisher, P. (1993). *Grain Refining and the Aluminium Industry (Past, Present and Future)*. Aluminium Casthouse Technology.
- [2] Sigworth, G.K. & Kuhn, T.A. (2007). Grain refinement of aluminum casting alloys. *International Journal of Metalcasting*. 1, 31-40.
- [3] Stefanescu, D. (2015). *Science and engineering of casting solidification*. Springer.
- [4] Spittle, J. (2013). Grain refinement in shape casting of aluminium alloys. *International Journal of Cast Metals Research*.
- [5] Cooper, P., Jacop, A., Detomi, A. (2000). *Additive developments in the aluminium industry*. Publisher.
- [6] Quested, T. (2004). Understanding mechanisms of grain refinement of aluminium alloys by inoculation. *Materials Science and Technology*. 20, 1357-69.
- [7] Cooper, P., Hardman, A., Boot, B., Burhop, E. (2003). *Characterisation of New Generation of Grain Refiners for the Foundry Industry*, 132. Publisher.
- [8] McKay, B., Nunner, G., Geier, G. & Schumacher, P. (2009). Impurities in Al-5Ti-1B grain refiner rod. *International Journal of Cast Metals Research*. 22, 212-5.
- [9] Boot, D., Cooper, P., StJohn, D., Dahle, A. (2002). *A Comparison of Grain Refiner Master Alloys for the Foundry*. TMS. Elsevier Ltd.
- [10] Parton, D., Hedges, M. (1996). *A Guide to Melt Treatment in the Aluminium Foundry*. London & Scandinavian Metallurgical, Londres.
- [11] Górny, M., Sikora, G. & Kawalec, M. (2016). Effect of Titanium and Boron on the Stability of Grain Refinement of Al-Cu Alloy. *Archives of Foundry Engineering*. 16(3), 35-38.
- [12] Górny, M. & Sikora, G. (2014). Effect of Modification and Cooling Rate on Primary Grain in Al-Cu Alloy. *Archives of Foundry Engineering*. 14(3), 21-24.
- [13] Mohanty, P. & Gruzleski, J. (1995). Mechanism of grain refinement in aluminium. *Acta Metallurgica et Materialia*. 43, 2001-12.
- [14] Arnberg, L., Bäckerud, L. & Klang, H. (1982). Intermetallic particles in Al-Ti-B-type master alloys for grain refinement of aluminium. *Metals Technology*. 9, 7-13.
- [15] Easton, M. & Stjohn, D. (1999). Grain refinement of aluminum alloys: Part I. The nucleant and solute paradigms—a review of the literature. *Metallurgical and Materials Transactions A*. 30, 1613-23.
- [16] Easton, M. & StJohn, D. (1999). Grain refinement of aluminum alloys: Part II. Confirmation of, and a mechanism for, the solute paradigm. *Metallurgical and Materials Transactions A*. 30, 1625-33.
- [17] Schaffer, P.L. & Dahle, A.K. (2005). Settling behaviour of different grain refiners in aluminium. *Materials Science and Engineering A*. 413, 373-8.
- [18] Sigworth, G.K. (1984). The grain refining of aluminum and phase relationships in the Al-Ti-B system. *Metallurgical Transactions A*. 15, 277-82.
- [19] Cook, R. (1998). *Modification of aluminium-silicon foundry alloys*. London: London & Scandinavian metallurgical Co Limited. 12-4.
- [20] Kim, J-H., Choi, J-W., Choi, J-P., Lee, C-H., Yoon, E-P. (2000). A study on the variation of solidification contraction of A356 aluminum alloy with Sr addition. *Journal of Materials Science Letters*. 19, 1395-8.
- [21] Dahle, A., Nogita, K., McDonald, S., Dinnis, C. & Lu, L. (2005). Eutectic modification and microstructure development in Al-Si Alloys. *Materials Science and Engineering A*. 413, 243-8.
- [22] Dahle, A., Nogita, K., McDonald, S., Zindel, J. & Hogan, L. (2001). Eutectic nucleation and growth in hypoeutectic Al-Si alloys at different strontium levels. *Metallurgical and Materials Transactions A*. 32, 949-60.
- [23] Nogita, K., Yasuda, H., Yoshida, K., Uesugi, K., Takeuchi, A., Suzuki, Y. & Dahle, A.K. (2006). Determination of strontium segregation in modified hypoeutectic Al-Si alloy by micro X-ray fluorescence analysis. *Scripta materialia*. 55, 787-90.
- [24] Tupaj, M., Orłowicz, A.W., Mróz, M., Trytek, A. & Markowska, O. (2016). Usable Properties of AlSi7Mg Alloy after Sodium or Strontium Modification. *Archives of Foundry Engineering*. 16(3), 129-132.
- [25] Liu, L., Samuel, A., Samuel, F., Doty, H. & Valtierra, S. (2004). Characteristics of α -dendritic and eutectic structures in Sr-treated Al-Si casting alloys. *Journal of Materials Science*. 39, 215-24.
- [26] Nielsen, Ø. & Olsen, S.O. (2013). Experiment for quantification of feedability and permeability in industrial aluminium alloys. *International Journal of Cast Metals Research*.

- [27] Dispinar, D., Ellingsen, K., Sabatino, M.D., Arnberg, L. (2008). Measurement of permeability of A356 aluminum alloys. 2nd Int Conf Advances in Solidification Process.
- [28] Ross, P.J. (1988). *Taguchi Techniques for Quality Engineering: Loss Function, Orthogonal Experiments, Parameter and Tolerance Design*. International Edition.
- [29] Braszczyńska-Malik, K.N. (2014). Mg-Al-RE Magnesium Alloys for High-Pressure Die-Casting. *Archives of Foundry Engineering*. 14(2), 49-52.
- [30] Kapisz, M., Durat, M. & Ficici, F. (2011). Friction and wear studies between cylinder liner and piston ring pair using Taguchi design method. *Advances in Engineering Software*. 42, 595-603.