

PILOT IMPLEMENTATION OF THE ON-LINE PARTIAL DISCHARGE MONITORING SYSTEM FOR HEADS OF THE HIGH VOLTAGE CABLE LINES

Michał Konarski, Paweł Węgierek

Lublin University of Technology, Faculty of Electrical Engineering and Computer Science, Nadbystrzycka 38 A, 20-618 Lublin, Poland (michal.konarski@energotech.info.pl, p.wegierek@pollub.pl, +48 81 538 4347)

Abstract

The article presents the assumptions, characteristics and description of the implementation of a pilot system for on-line monitoring of partial discharges in heads of the high-voltage cable lines. The main purpose of the implementation was to increase the reliability of cable line heads by equipping them with a system of continuous assessment of technical condition with direct transmission of measurement data and alarms to the SCADA system. In order to achieve the assumed goal, unconventional methods for measuring partial discharges were used, the application of which does not require disconnecting the line from the voltage. The implementation was carried out on an active 110 kV high voltage cable line in the area of activity of one of the Distribution System Operators.

Keywords: cable lines diagnostics, partial discharges, unconventional methods of partial discharges measurement, UHF electromagnetic method.

© 2020 Polish Academy of Sciences. All rights reserved

1. Introduction

Growing customer demands for continuity of electricity supply combined with the current quality regulatory model [1] require distribution companies to continuously develop their electrical grids in order to improve power supply reliability. Despite the significant increase in investment outlays in the distribution grid in recent years (including the solutions described by the authors in [2]), the reliability indicators of the power supply in the Polish power grid still differ significantly from the European average [3]. The Polish power grid is still mainly an overhead grid, which is why it is particularly vulnerable to damage caused by atmospheric phenomena. Currently, in order to eliminate the impact of weather conditions on the reliability of power supply to consumers, the investments of *distribution system operators* (DSOs) have been focused on the reconstruction of existing overhead lines into cable lines. The intensification of the construction of new cable lines, combined with the need to improve the reliability of power supply, makes it particularly important to ensure trouble-free operation of both new and existing cable lines. Ensuring trouble-free operation of the cable line requires the use of

appropriate methods to assess its technical condition. The main task of the assessment is to detect potential damage before it occurs. An ideal tool for diagnosing the technical condition of cable lines is the measurement of *partial discharges* (PDs) occurring in insulation, whose increased activity indicates an impending failure. This is particularly important for lines and devices in operation where, since the acceptance tests, the condition of the insulation may have deteriorated due to degradation, ageing processes or increased operating temperature. Due to the disadvantages of currently used methods of diagnostic partial discharges (presented by the authors in publication [4]), in recent years standards for the detection of partial discharges by unconventional methods have been developed, as described in the IEC TS 62478:2016 standard [5]. Unconventional methods of detecting partial discharges allow to determine the level of partial discharges in the tested object, without the need to disconnect the line from voltage. The described advantages of unconventional measurement methods caused that steps were taken towards their implementation in the power grid in the form of continuous on-line monitoring systems for partial discharges. This article describes the pilot implementation of an innovative on-line diagnostics system for partial discharges in high-voltage cable lines in the area of operations of one of the DSOs.

2. Unconventional partial discharges measurement methods and existing commercial on-line PD monitoring systems

The phenomenon of partial discharges is associated with all types of high voltage electrical equipment, such as cable lines, switchgears, transformers, generators and motors. Regardless of the type of device, the occurring discharges can lead to damage in the insulation system. There are currently several methods for detecting partial discharges, and their applicability is directly related to the type of device. The occurring partial discharge is in fact a high frequency current pulse caused by a breakdown of part of the insulating material. The basic and most common method for measuring partial discharges is the electrical method, in accordance with the IEC 60270:2000 standard [6]. This method enables direct measurement of the apparent charge of occurring current pulses, making it the most accurate method. The main disadvantage of the electrical method is the need to switch off the tested object under voltage during tests. However, the energy accompanying the current impulses of the partial discharge is emitted to the external environment in various forms [7-11]. Owing to measurements of physical quantities proportional to the occurrence of partial discharges, there is a possibility of indirect measurement of their level – they are called unconventional methods for measuring partial discharges. Due to the lack of the need to disconnect the tested object from voltage during testing, unconventional methods are suitable for use in on-line diagnostic systems of partial discharges.

The unconventional methods of measuring the partial discharges, can be divided into [12, 13]:

- The electromagnetic method, consisting of measuring the level of electromagnetic radiation in the VHF and UHF waves, propagating both in galvanic elements connected to the source of partial discharges (*e.g.* grounding) and in the medium surrounding the source of discharges (air or oil);
- The acoustic method, based on the measurement of an acoustic wave in ultrasound field of, propagating in the medium surrounding the source of partial discharges, the source of which is the mechanical deformation of the medium during discharge;
- The chemical method, consisting in the analysis of chemical reaction products occurring in oil under the influence of partial discharges (gas chromatography);

- The spectrophotometric method, consisting in the analysis of the spectrum of light emitted during partial discharges, possible only to be used in media with good light transmission;
- The thermal method, consisting of measuring local heat emission at the place of occurrence of partial discharges.

The unconventional methods of measuring partial discharges presented above have recently started to be used in on-line monitoring systems for partial discharges dedicated to various power devices. The most widespread systems, their characteristics and range of applications are presented below.

Omicron MONCABLO – a cable line monitoring system using the electromagnetic method and HFCT (*High Frequency Current Transformer*) sensors. The sensors are mounted on the return conductors of the cable terminations and cross-bonding joints, enabling their continuous monitoring of partial discharges. The system, apart from the sensors, also consists of a processing unit and a server with a dedicated application. The applied HFCT sensors are characterized by a measuring range only up to 40 MHz (analyzer up to 30 MHz), which makes it impossible to detect higher frequency discharges, which is the main limitation of the system's capabilities [14].

doublePRIME PD-Guard – a universal partial discharge monitoring system dedicated to transformers, rotating machines, cable lines and gas-insulated switchgears. For partial discharges detection, the system uses the electromagnetic method and various types of sensors: omnidirectional and directional antennas, HFCT sensors, capacitive dividers for cable terminations and valve probes for transformers. The system works in a wide frequency range up to 1000 MHz, thanks to which it can detect the majority of partial discharges. The diverse and extensive system infrastructure as well as advanced method of PD frequency analysis in each analyzer result in the high price of this solution [15].

Prysmian PRY-CAM – a system dedicated to all power devices using the electromagnetic method and sensors in the form of antennas installed in dedicated casings. Using only antennas to detect partial discharges results in lower accuracy and precision of measurements. The disadvantage of the system is also the small measuring range (up to 50 MHz) [16].

Eaton InsulGard – a system designed for monitoring of medium voltage equipment – generators, motors, switchgears and transformers. HFCT sensors and capacitive dividers connected directly to live parts are used to detect partial discharges by the electromagnetic method. The system operates in the frequency range up to 20 MHz, which means that the ability to detect all discharges is definitely limited [17].

Qualitrol PDM – a monitoring system for transformers and switchgears in gas insulation (GIS) using the electromagnetic method and sensors dedicated to monitored devices (valve probes, capacitive dividers and antennas). The system operates in a very wide frequency range up to 2000 MHz, enabling detection of practically all discharges. The disadvantage of the system is the limitation of its monitoring capabilities only to transformers and GIS switchgears as well as the large size of the entire system, resulting in the high price of the solution [18, 19].

3. The pilot installation of on-line partial discharges monitoring system

The main purpose of the monitoring installation was to use unconventional partial discharge detection methods to continuously assess the technical condition of a high voltage cable line. The key task of the system is to immediately notify the line operator of exceeding the acceptable level of partial discharges, which indicates an impending failure. The first stage of the research work preceding the implementation of the complete system was to equip the existing 110 kV high

voltage power line only with PD sensors using the UHF method for detecting partial discharges (based on the measurement of electromagnetic radiation in the ultra-high frequency range) [20]. Assumptions, description of the implementation and conclusions from the carried out research work are presented in [4]. The knowledge acquired during the assembly and testing of the UHF sensors were used to design, manufacture and install a complete system for online monitoring of PD level in cable terminations. The previously acquired information was used to optimize installation of sensors and the initial configuration of the diagnostic system alarms to eliminate the impact of weather conditions and external interference on its operation.

The 110 kV high voltage cable line covered by the implementation of the complete monitoring system was made with the 3×XRUHKXS 1×630RMC/95 64/110(123) kV cable ended with dry cable terminations. The total length of the cable line is about 740 m, on one side of the line there is a transition to the overhead line, and on the other it is led to the gateway at the HV/MV substation. Both ends of the line are equipped with surge arresters.

As in the first stage of implementation, Doble LDWS-T sensors were used as partial discharge sensors (Fig. 1), which are in fact capacitive dividers operating in the UHF band (100 MHz–1 GHz). The UHF sensors allow the measurement of partial discharges by the unconventional method in a continuous mode (when supplying the line with 110 kV 50 Hz operating voltage), without disconnecting it from the voltage (in accordance with IEC TS 62478:2016 standard). The applied sensors enable direct detection of partial discharges in cable terminations. Through the propagation of the electromagnetic wave in both the air and the cable’s return wire, the sensors can simultaneously detect partial discharges in the equipment surrounding the terminations (surge arresters and close section of the cable).

The sensors were mounted in parallel to the support insulators of the cable terminations on both sides of the cable line (6 pieces in total), and the measuring waveguides (connected to the sensors via the TNC socket) were brought to the measuring cabinets. The method of mounting the UHF sensor on the cable head is shown in Fig. 2.



Fig. 1. Partial discharge sensor using the UHF method – a Doble LDWS-T.



Fig. 2. Mounting method of a UHF sensor on the cable head.

NDB PD Annunciator partial discharge analyzers (Fig. 3), operating in accordance with the IEC TS 62478: 2016 standard, were used to obtain and analyze measurement data in continuous

mode and to configure the system accordingly. A single analyzer enables connection of up to 3 partial discharge sensors working in the UHF band (the measurement band for the analyzer is from 10 MHz to 500 MHz) as well as conversion of the measurement signal to digital data and their transmission via the MODBUS protocol.



Fig. 3. Partial discharges analyzer – NDB PD Annunciator.

The analyzer does not perform frequency analysis of the measuring signal, making it much more economical than competing solutions. The built-in function of the analyzer is also the configuration and transmission of alarms on exceeding the level of partial discharges in the monitored terminations.

The main function of the developed system is continuous monitoring of the level of partial discharges and transmission of measurement data and alarms directly to the SCADA system to allow remote assessment of the technical condition of the cable line. As previously mentioned, in most cases, a complete breakdown of insulation is preceded by the activity of partial discharges, thanks to which the real-time knowledge of the level of partial discharges allows for the early detection of potential damage and planning appropriate corrective actions. Depending on the location of the measurement system (pole or gate at the HV/MV substation), a different set of accompanying equipment was used, enabling the correct operation of the entire system. Block diagrams of both measuring stands are shown in Fig. 4 (pole stand) and Fig. 5 (stand in the main power supply point).

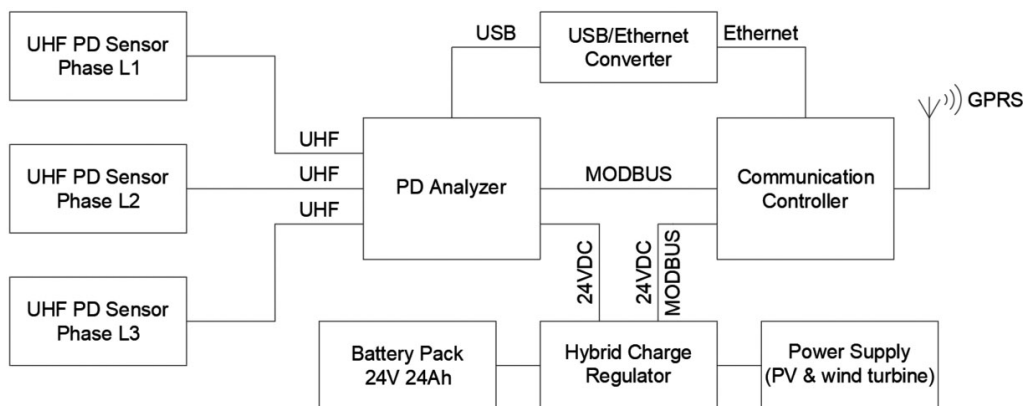

Fig. 4. Block diagram of the measuring stand on the high voltage pole.

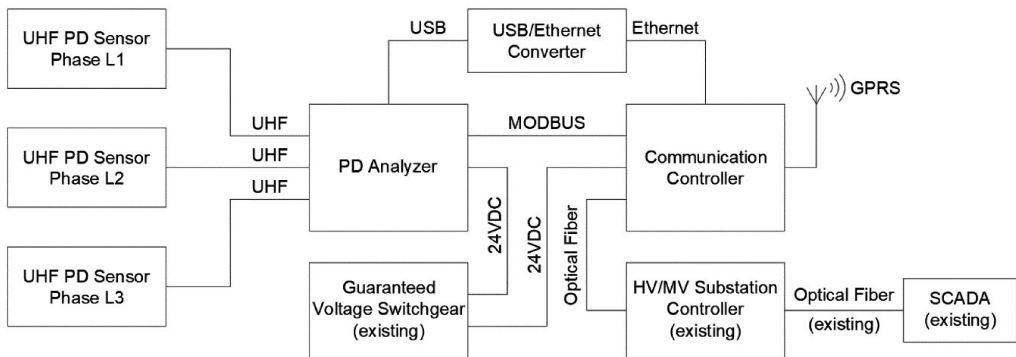

Fig. 5. Block diagram of the measuring stand at the gate of the HV/MV substation.

The partial discharge monitoring station located at the gate of the HV/MV substation is equipped with:

- Doble LDWS-T partial discharge UHF sensors mounted at the cable terminations of each phase (3 pcs.);
- an NDB PD Annunciator partial discharge analyzer, collecting, analyzing and sending measurement data via MODBUS protocol;
- an Elkomtech Ex-BRG3 communication controller, converting data from the analyzer to DNP3 protocol, understandable for existing telecommunications infrastructure, equipped with GSM/GPRS modem.

The devices installed in the area of the HV/MV substation were supplied directly from the existing guaranteed power supply switchgear located in the building of the substation control room. Transmission of measurement data from the measuring node to the SCADA system was carried out via the existing Elkomtech Ex-MST2 station data concentrator in the control room, connected to the SCADA system via DSO fiber optic communication. Communication between the partial discharge analyzer and the communication controller is performed with the MODBUS protocol. The controller is connected to the station concentrator by a fiber optic connection. In parallel to the MODBUS protocol, remote access to the partial discharge analyzer was implemented using a USB/Ethernet converter, also connected to the Ex-BRG3 communication controller. The parallel engineering link allows to remotely change the device configuration using the manufacturer's dedicated application and provides access to archival measurement data stored directly on the device without blocking the measurement link.

The measuring station located on the high voltage pole was additionally equipped with:

- a power supply set consisting of 2 photovoltaic panels with a rated power of 50 W each and a wind turbine with a rated power of 300 W;
- a hybrid charging regulator stabilizing voltage at 24 V DC and managing the operation of the power supply system;
- a 24 V 24 Ah accumulator battery to maintain equipment operation in the absence of power.

The use of an autonomous power supply system was necessary due to the lack of an external power source on the high voltage pole. Similarly to the station at the substation, communication between the partial discharge analyzer and the communication controller is performed with the

MODBUS protocol. As in the case of the station at the substation, parallel to the MODBUS protocol, remote access to the partial discharge analyzer was implemented using a USB/Ethernet converter. Transmission of measurement data from the controller to the SCADA system was carried out using GPRS communication, via the Ex-BRG3 twin controller located in the test stand at the substation (point-to-point transmission), which is connected to the SCADA system via the Ex-MST2 station data concentrator.

Fig. 6 shows the UHF signal waveforms as a function of time from sensors located on all the three phases of the monitored cable line (pole stand). The pink colour was used for phase L1, grey for phase L2 and blue for phase L3. As can be seen, UHF signal levels are stable, approximately equal in all the monitored heads and they do not exceed the level of alarms set to 30 dB. This means that in any of the terminations, partial discharges currently do not develop. The measuring stand at the other end of the line is also characterized by very similar UHF signal levels, which proves good technical condition of the entire tested cable line. Due to the presence in the air of electromagnetic waves of various origins (such as radio waves, television or mobile telephony), these signals are also captured by UHF sensors, which causes the measurement background and external interference during the measurement, which is manifested by the presence of an external constant component in the waveforms partial discharge signal, even in the absence of partial discharges.

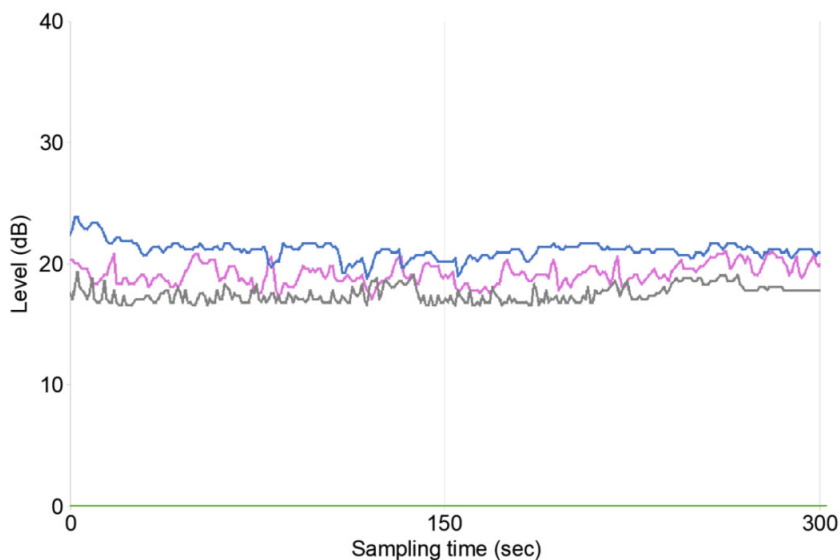

Fig. 6. Time courses of partial discharges activity – HV pole stand.

4. Conclusions

The on-line partial discharge monitoring system presented in the article consists of devices from various manufacturers that have not yet been used in one measurement system. Among others, the authors applied partial discharge sensors by Doble, a partial discharge analyzer by NDB and a communication controller by Elkomtech. The concept of an innovative measurement system was developed, and then the selection and integration of individual devices was made, their

cooperation within the integrated measurement system was verified, including the configuration of devices in terms of data transmission protocols and determination of threshold values of recorded signals for individual types of alarms. The power supply and control module for the pole stand has been developed, designed and manufactured from scratch, including a power supply system based on renewable energy sources (a hybrid system consisting of photovoltaic panels and a wind turbine) and a signaling system in accordance with the requirements of the Distribution System Operator. Preparation of the concept and a proposal for visualization of the system operation in the SCADA system, which, after being approved by the DSO, has been implemented and currently allows the dispatching services to assess the technical condition of the analyzed cable line. The solution presented in this article was the first implementation of the discussed system in such a configuration and, in general, the first in Poland system of on-line monitoring of partial discharges installed in cable lines.

The developed solution is in line with current trends in the development of diagnostic methods and systems for monitoring the technical condition of power networks and is a response to the needs of the power industry, which is confirmed by its implementation by one of the distribution system operators.

The advantages of the system and features confirming its innovation include:

- satisfying the need to improve the reliability of power supply to electricity consumers requires the use of fast and unreliable methods to assess the technical condition of power lines;
- being an ideal tool for diagnosing the technical condition of cable lines is the measurement of partial discharges occurring in insulation, whose increased activity indicates an impending failure;
- use of unconventional methods of measuring partial discharges allows continuous monitoring of the technical condition of cable lines without the need to switch off the line from voltage;
- the developed complete on-line monitoring system which enables detection of potential damage before it occurs and immediately notifies the line operator of an impending failure;
- the developed monitoring system enables, thanks to full integration with SCADA, completely maintenance-free diagnostics of the technical condition of power equipment in continuous operation;
- advanced alarm configuration methods allow separation from external interference and eliminate the impact of weather conditions on external signaling;
- the cable line covered by the implementation did not show an increased level of partial discharges, which indicates its correct performance and the lack of developing damage.
- the use of capacitive dividers in the measuring system with a wide frequency range makes it possible to detect the majority of partial discharges in monitored cable heads;
- the architecture simplified compared to the extensive monitoring systems and the departure from the frequency analysis of partial discharges in each analyzer results in lowering the costs of the developed solution, while maintaining full functionality as a system signaling exceeding the allowable level of partial discharges.

The above-mentioned advantages of the developed metering system give the opportunity to improve the quality standards of electricity distribution, by limiting the number and duration of interruptions in energy supply to the final consumer, thus ensuring high chances for extensive system implementation in the high-voltage distribution network.

Acknowledgements

This work was supported by Ministry of Investment and Economic Development and co-financed from the European Union funds under the Smart Growth Operational Programme (grant # POIR.02.01.00-00-0005/17).

References

- [1] Energy Regulatory Office (2015). *Regulacja Jakościowa w latach 2016–2020 dla Operatorów Systemów Dystrybucyjnych*, Warsaw. (in polish)
- [2] Konarski, M., Węgierek, P. (2018). The use of power restoration systems for automation of medium voltage distribution grid. *Przegląd Elektrotechniczny*, 94(7), 167–172.
- [3] Council of European Energy Regulators (2018). *Benchmarking Report 6.1 on the Continuity of Electricity and Gas Supply*, Brussels: CEER.
- [4] Konarski, M., Węgierek, P. (2019). Application of the UHF method for partial discharges measurement in high voltage cable lines. *Przegląd Elektrotechniczny*, 2019, 95(6), 86–89.
- [5] IEC TS 62478:2016 High voltage test techniques – Measurement of partial discharges by electromagnetic and acoustic methods. International Electrotechnical Commission.
- [6] IEC 60270:2000 High-voltage test techniques – Partial discharge measurements. International Electrotechnical Commission.
- [7] Zygarlicki, J., Mroczka, J. (2012). Variable-frequency Prony method in the analysis of electrical power quality. *Metrology and Measurement Systems*, 19(1), 39–48.
- [8] Zygarlicki J., Mroczka J. (2012). Method of testing and correcting signal amplifiers' transfer function using Prony analysis. *Metrology and Measurement Systems*, 19(3), 489–498.
- [9] Zygarlicki, J., Mroczka, J. (2012). Prony's method used for testing harmonics and interharmonics in electrical power systems. *Metrology and Measurement Systems*, 19(4), 659–672.
- [10] Zygarlicki, J., Mroczka, J. (2014). Prony's method with reduced sampling-numerical aspects. *Metrology and Measurement Systems*, 21(3), 521–534.
- [11] Zygarlicki, J., Mroczka, J. (2011). Short time algorithm of power waveforms fundamental harmonic estimation with use of Prony's methods. *Metrology and Measurement Systems*, 18(3), 371–378.
- [12] Yaacob, M.M., Alsaedi, M.A., Rashed, J.R., Dakhil, A.M., Atyah, S.F. (2014). Review on partial discharge detection techniques related to high voltage power equipment using different sensors. *Photonic Sensors*, 4(4), 325–337.
- [13] Wu, M., Cao, H., Cao, J., Nguyen, H.L., Gomes, J.B., Krishnaswamy, S.P. (2015). An overview of state-of-the-art partial discharge analysis techniques for condition monitoring. *IEEE Electrical Insulation Magazine*, 6(31), 22–35.
- [14] MONCABLO Brochure, Omicron Energy. (2018) <https://www.omicronenergy.com/download/document/60A31CB9-AE62-47D1-BD5A-B2E0443FA6EB/> (accessed on Apr. 2020).
- [15] doblePRIME PD-GUARD Datasheet, Doble Engineering Company. (2018). https://www.doble.com/wp-content/uploads/doblePRIME-PD-Guard_web.pdf (accessed on Apr. 2020).
- [16] PRY-CAM Brochure, Prysmian Electronics. <https://dk.prysmiangroup.com/sites/default/files/atoms/files/Pry-Cam%20Brochure.pdf> (accessed on Apr. 2020).

- [17] InsulGard Brochure, Eaton Industries. (2011). http://www.eaton.com.cn/EN/ecm/idcplg?IdcService=GET_FILE&allowInterrupt=1&RevisionSelectionMethod=LatestReleased&noSaveAs=0&Rendition=Primary&dDocName=PCT_310863 (accessed on Apr. 2020).
- [18] QUALITROL QPDM Product Brochure, Qualitrol Company. https://2hfybu1lrdue3x9wnu1dvw7s-wpengine.netdna-ssl.com/wp-content/uploads/2019/08/Qualitrol_QPDM_Partial_Discharge_Monitor_for_Transformers.pdf (accessed on Apr. 2020).
- [19] QUALITROL PDMG-RH Product Brochure, Qualitrol Company. (2012). https://2hfybu1lrdue3x9wnu1dvw7s-wpengine.netdna-ssl.com/wp-content/uploads/2016/09/PD-D27-07L-01E_PDMG_RH.pdf (accessed on Apr. 2020).
- [20] Álvarez, F., Garnacho, F., Ortego, J., Sánchez-Urán, M.Á. (2015). Application of HFCT and UHF sensors in on-line partial discharge measurements for insulation diagnosis of high voltage equipment. *Sensors*, 15(4), 7360–7387.