



Research paper

Application of ultrasonic pulse velocity test to concrete assessment in structures after fire

J. Wróblewska¹, R. Kowalski², M. Głowacki³, B. Juchnowicz-Bierbasz⁴

Abstract: The paper presents the description and results of ultrasonic pulse velocity tests performed on heated beams. The studies aimed to verify the suitability of the UPV method for the assessment of the damaged external layer in the cross-section of RC members after a fire. Four beams heated in a planned way from the bottom (a one-way heat transfer) for 60, 120, 180 and 240 minutes and one unheated beam were examined. The tests were performed using an indirect UPV method (linear measurement on the heated surface). Reference tests were conducted using a direct UPV method (measurement across the member section, parallel to the isotherm layout). Exponential transducers were used for testing concrete surface, which was degraded in high temperature and not grinded. The estimated thicknesses of the destroyed external concrete layer corresponded to the location of the isotherm not exceeding 230°C. Therefore, this test can be used to determine at which depth in the member cross-section the concrete was practically undamaged by high temperature.

Keywords: concrete, high temperature, UPV method, linear measurement, exponential transducers

¹ MSc., Eng., Warsaw University of Technology, Faculty of Civil Engineering, Al. Armii Ludowej 16, 00-637 Warsaw, Poland, e-mail: j.wroblewska@il.pw.edu.pl, ORCID: <https://orcid.org/0000-0003-3383-4223>

² Prof., PhD., Eng., Warsaw University of Technology, Faculty of Civil Engineering, Al. Armii Ludowej 16, 00-637 Warsaw, Poland, e-mail: r.kowalski@il.pw.edu.pl, ORCID: <https://orcid.org/0000-0002-0876-3489>

³ PhD., Eng., Warsaw University of Technology, Faculty of Civil Engineering, Al. Armii Ludowej 16, 00-637 Warsaw, Poland, e-mail: m.glowacki@il.pw.edu.pl, ORCID: <https://orcid.org/0000-0003-2494-3225>

⁴ MSc., Eng., Warsaw University of Technology, Faculty of Civil Engineering, Al. Armii Ludowej 16, 00-637 Warsaw, Poland, e-mail: b.juchnowicz@il.pw.edu.pl, ORCID: <https://orcid.org/0000-0002-4511-8235>

1. Introduction

Reinforced concrete structures have a relatively good natural fire resistance and usually do not require demolition or replacement after a fire. Due to the low thermal diffusivity of concrete, heat penetrates slowly into the member and the concrete cover insulates the reinforcement. This usually allows the structure to maintain a relatively good load-bearing capacity both during and after a fire. According to the textbook [1], the fire resistance of typical slender RC members is about 50–60 minutes, even if they were not specifically designed for fire conditions. Applying the recommendations of the Eurocode [2] concerning cross-sectional dimensions and axis distance of reinforcement from the concrete surface, allows constructing members of 4h-fire resistance (standard fire).

However, in RC structural members exposed to fire, a number of thermo-mechanical, physical, and chemical processes occur in the microstructure of concrete [3–6]. Concrete compressive strength decreases in high temperature, which may have a significant effect on the reduction of the structural load-bearing capacity. From a practical point of view, concrete heated to 500–600°C may be considered destroyed (approximately a 50% decrease in compressive strength in high temperature). For a fully developed fire in a compartment of moderate size (such a fire is well represented [7] by the standard curve [8]), the ambient temperature around the structure may reach 950°C after 60 minutes and 1150°C after 240 minutes. The extent of the damaged concrete layer defined as the location of the 500°C isotherm from the member surface, e.g. in beams and columns, may be up to 3 cm after 60 minutes and 12 cm after 240 minutes [9]. This extent can be greater when thermal spalling of concrete occurs intensively. For other fire curves, the temperatures may be even higher. For a hydrocarbon curve, the temperature is 1100°C after only 30 minutes and remains approximately constant after 240 minutes. For a tunnel fire curve, the temperature is 1350°C after 60 minutes and 1200°C after 240 minutes [6]. Hence, for such fires, the extent of the 500°C isotherm may be even greater than for a standard fire.

In fire conditions, there is an unsteady heat transfer in the cross-section of RC members [10–12]. Due to the low thermal diffusivity of concrete, the temperature is much higher on the member surface than inside. As a result, concrete does not have uniform properties in the cross-section. The greatest concrete degradation and reduction of its compressive strength occurs in the near-surface zone [13–15]. Therefore, during the assessment of structures after a fire, it is particularly important to determine the thickness of the external cross-section layer of the member in which the concrete is damaged to such an extent that it should be considered destroyed [16–20].

The paper presents the description and results of ultrasonic pulse velocity (UPV) tests performed on beams heated from the bottom. The studies aimed to verify the reliability and the suitability of the indirect UPV method for the assessment of the damaged external layer in the cross-section of RC members after a fire.

2. Indirect UPV method

The standardized UPV method [21] is commonly used to test in situ concrete. The time of ultrasonic wave passage in concrete between the transmitting and receiving transducers placed on member surfaces is measured. In ordinary room conditions, concrete compressive strength can be estimated from the wave velocity based on correlation relationships. These correlations make use of the dependence of the velocity of ultrasonic wave propagation on Young's modulus value and the moisture content.

According to the report [22], the UPV method may also be a good indicator of the degree of concrete damage in structures after a fire. As a result of thermomechanical and chemical processes occurring in concrete heated to high temperature, Young's modulus of concrete and the amount of contained water decrease [23–24].

In ordinary room conditions, a direct UPV test can be used for structural members in which the concrete is approximately uniform and the access is possible from both sides of the member (e.g. columns, beams [25–27]). The transducers are placed on the opposite surfaces of the member, and the obtained wave velocity is the average value for its entire thickness. To test members with one-sided access (e.g. walls, slabs), it is advisable to use an indirect UPV method in which both transducers are applied to the same surface.

Concrete in structures after a fire usually has non-uniform properties. Employing the direct test to post-fire assessment of members would only allow obtaining an averaged velocity of the wave which propagates both through the zone damaged by high temperature and the undamaged concrete. Therefore, for the post-fire assessment of concrete damage in structures, only the indirect method is suitable.

The guidelines [22] based on the methodology presented in the paper [28] describe the use of indirect ultrasonic testing to estimate the extent of concrete damage in heated members (Fig. 1). The assumption is that it is possible to distinguish between the surface layer of concrete with worse mechanical parameters (damaged layer) and the concrete inside the cross-section, not damaged by high temperature. The time of ultrasonic wave passage is measured for gradually increased

distances between the transducers. In the diagram of the relationship between the distance (x) separating the transducers and the wave travel time (t), a characteristic change in the tilt should occur for the abscissa marked x_0 . This is the distance between the transducers for which travel time of waves in the surface layer (path 1 – lower wave velocity (v_d) in damaged concrete) is equal to travel time in deeper layers of cross-section (path 2 – higher wave velocity (v_s) in undamaged concrete). Thickness (d_i) of the damaged concrete layer can be estimated using the following formula [22]:

$$(2.1) \quad d_i = \frac{x_0}{2} \sqrt{\frac{v_s - v_d}{v_s + v_d}}$$

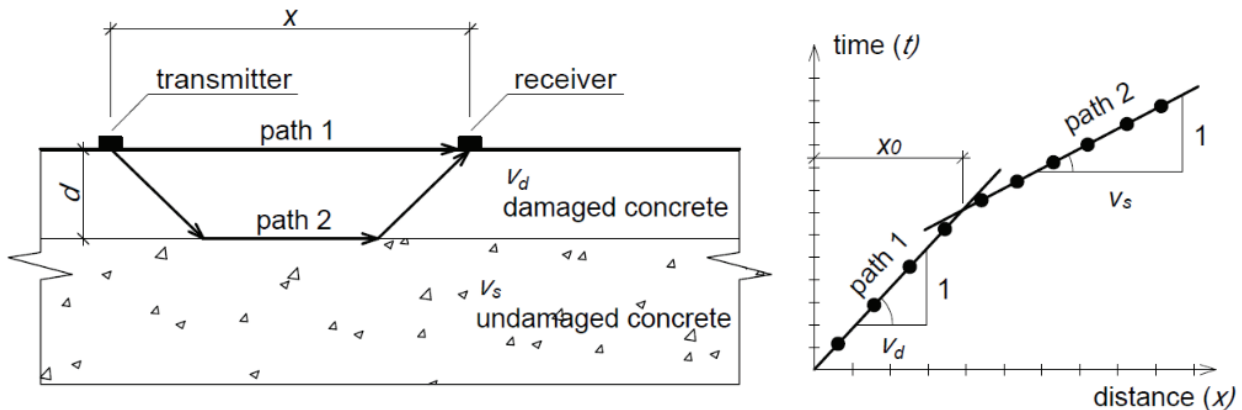

Fig. 1. Scheme of ultrasonic pulse velocity measurement and the assessment of damaged concrete layer thickness using the indirect UPV method (according to [22])

It should be noted that the layer layout considered in Fig. 1, being the basis for Eq. (2.1) derivation, does not fully correspond to reality. In Fig. 1, two layers of concrete with uniform parameters were distinguished. In fact, in members exposed to fire conditions, concrete in the surface layer has variable mechanical parameters, depending on the temperature to which it was subjected, i.e. the distance from the heated surface. Therefore, no sharp boundary between damaged and undamaged concrete can be defined. This boundary is “blurred” and can only be considered assumed. In simplified structural analyses, it is often assumed that the boundary between damaged and undamaged concrete corresponds to the position of 500°C isotherm in the member cross-section [29–30].

To obtain the appropriate acoustic coupling of cylindrical transducers (commonly used), the tested concrete surface should be smoothed and covered e.g. with grease. Exponential transducers of point contact with the surface do not require a coupling agent.

In the available literature, there are few studies using the indirect UPV method described above. In the case study of the Mont-Blanc Tunnel after a fire [31], seismic refraction was measured in concrete walls. The mechanical waves were induced by a steel ball hitting an anvil glued to the wall surface. In the papers [32–33] cylindrical transducers were applied to a flat surface of heated concrete panels to assess the thickness of the damaged concrete layer. The case study [34] concerns a warehouse slab exposed to fire conditions. The indirect UPV tests were performed on a flat area of the slab using cylindrical transducers.

The aim of the experimental study described in this paper was to verify the reliability and the suitability of the indirect UPV method for the assessment of concrete quality in structures after a fire (by estimating the thickness of the damaged concrete layer). In particular, consideration was given to testing rough concrete surface, which frequently occurs in members exposed to high temperature.

3. Experimental study

3.1. Beams

Five beams made of C35/45 concrete with siliceous aggregate (0–16 mm grain size) were examined (Fig. 2). The average compressive strength of the concrete determined on 150 mm cubes was 46.3 MPa after 28 days from casting and 60.8 MPa after about 4 months (an increase of strength by about 31%). To prevent unexpected damage, the members were reinforced with 8 mm-diameter bars made of steel with a characteristic yield strength of 500 MPa.

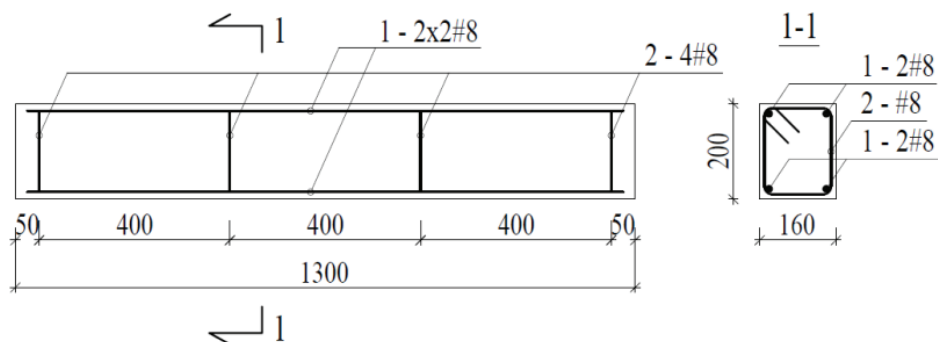

Fig. 2. Beams dimensions and reinforcement

The beams dimensions (1300 mm in length and 160×200 mm in cross-section) were designed to ensure proper support and uniform heating over the beam width (see Fig. 3). The height of the beam was determined to prevent excessive heating of the concrete in the upper part of the cross-section.

3.2. Testing procedure

Four beams were heated for 60, 120, 180 or 240 minutes using a height-adjustable electric furnace (Fig. 3a), and then cooled freely in the air. One beam was not heated. Before the test, the temperature in the furnace chamber reached 450°C. The furnace was then placed under the beam and the chamber temperature was increased to about 900°C. Immediately after placing the furnace under the beam, ceramic wool insulation was fixed to the beam lateral surfaces (Fig. 3a). In this way, a one-way heat transfer in the cross-section was provided. The temperature in the furnace chamber, on the beam surface and at selected points inside the cross-section was measured during the test (Fig. 3b).

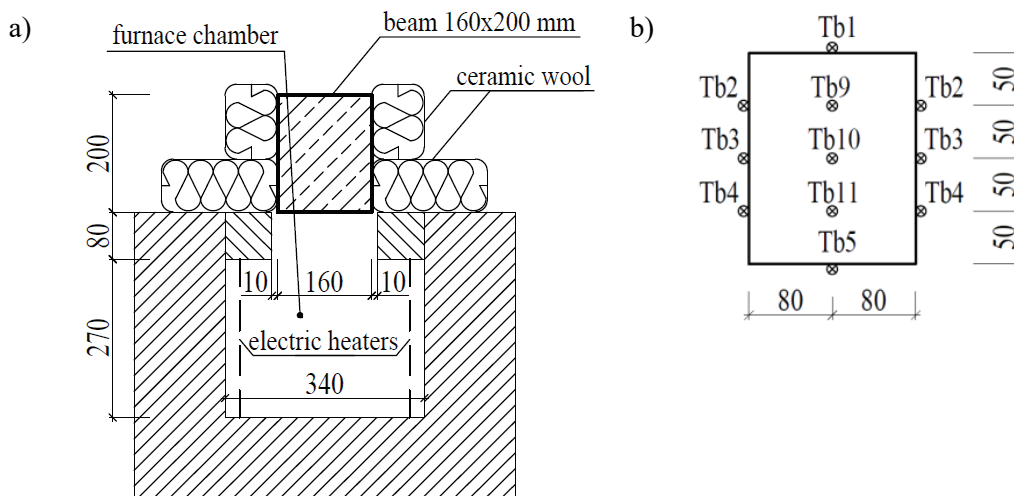

Fig. 3. Heating scheme: a) beam location in the furnace chamber, b) layout of temperature measurement points in the cross-section

After heating and cooling down, the 70-cm long central part of the beams was tested. Constant heating conditions were provided in the examined area. Under the influence of high temperature, the bottom of the tested members underwent significant degradation. The surface was rough, with exposed aggregate grains. It was not grinded before applying the transducers, although this is recommended for testing in normal conditions [21]. Such operation would significantly extend the testing time.

In normal conditions, the inspection is usually scheduled in advance. The structure condition does not endanger its safety and, due to the expected concrete uniformity, the number of measurement points may be significantly lower than during the post-fire examination. The effects of fire on the structure are usually random and non-uniform. Therefore, it cannot be concluded from the condition of concrete assessed at one location that, for example, at a distance of 1 or 2 m from that location, the condition will be the same. Moreover, after a fire, the state of the structure as a whole is not fully recognized. Before the tests are performed, the extent of fire damage is unknown. It is impossible to be 100% certain that there is no danger to the structure safety. Therefore, an assessment is needed immediately.

Taking the above into consideration, from a practical point of view, after a fire, it is only reasonable to perform a test in which, in a relatively short time, e.g. several hours, measurements can be taken in a large number of places, e.g. 20–30, without introducing unnecessary mechanical actions.

The tests were conducted on the heated bottom surface of the beams. First, an attempt was made to take the measurements using an indirect method [22], with the use of cylindrical transducers. However, despite the application of significant amounts of coupling agent, the proper contact between the transducers and concrete was not achieved. Difficulties were noted in reading the wave travel time at many measurement points. A very large scatter of results was obtained. It was therefore concluded that the measurements taken with the cylindrical transducers on an unpolished surface are unreliable and it is necessary to use exponential transducers in order to evaluate concrete after a fire.

The exponential transmitter was placed in one of six fixed positions (Fig. 4), on the longitudinal beam axis. The passage time of the ultrasonic wave travelling in the direction to the center of the beam, to the receiver located at a distance 5–60 cm from the transmitter, was measured. The receiver position was being gradually changed, in 5-cm steps. For each transmitter position, five linear measurements were taken in this way.

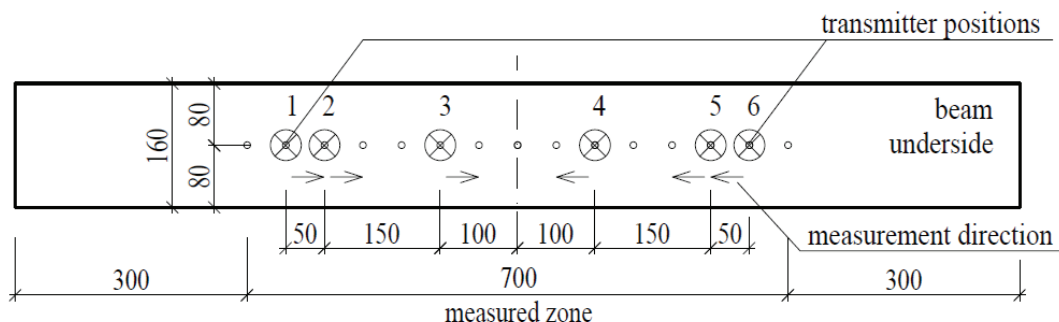

Fig. 4. Scheme of linear measurement – transmitter positions (beam underside view)

Additionally, a direct test was conducted. The time of ultrasonic wave passage across the beam section was measured by placing the exponential transducers on two opposite side surfaces of the member. For each beam, measurements were taken at subsequent levels corresponding to distances of 2, 4, 6, 8, 10, 12, 14, 16 and 18 cm from the bottom edge of the cross-section. In this way, the wave travel time was examined parallel to the isotherm layout, i.e. through uniformly heated concrete. The measurements described above may be considered a reference test. In practice, such a test would rather not be possible.

4. Experimental results

4.1. Temperature in the beam cross-section

In order to determine the isotherm layout in the heated beams cross-section, FEM calculations were performed in addition to the temperature measurements described above. The cross-section of the tested members was modelled in a SAFIR computer program [35]. A two-dimensional model made of orthogonal four-node elements with a side width of 10 mm was used. The parameters defining the thermal properties of concrete in the program were adopted according to the Eurocode [2]. The actual heating conditions were reflected by setting the average temperature measured at the bottom surface of the beam as input data for the FEM calculations. In this way, the effect of radiation in the furnace chamber on the heated beam surface, which is difficult to estimate, was eliminated.

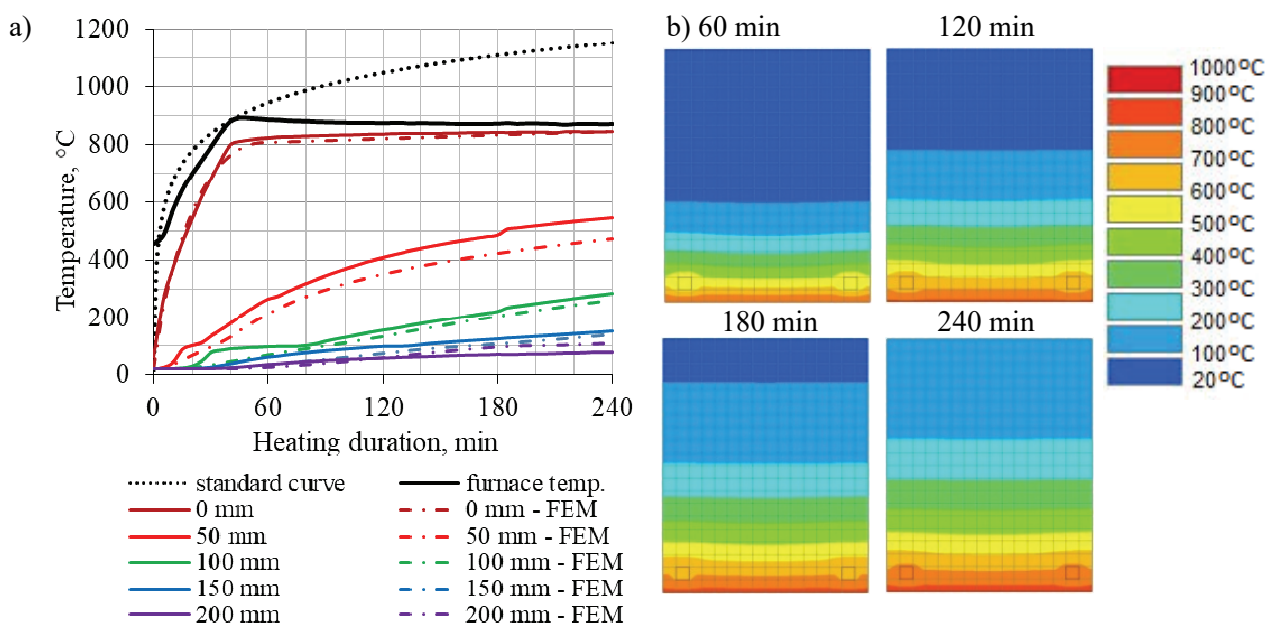

Fig. 5. Temperature in the beams cross-section: a) comparison of the temperature values obtained in experimental tests and in the FEM model, b) isotherm layout after a specified heating time

Fig. 5a presents a comparison of the calculation results with the values of temperature measured in particular cross-section points (layout of these points – see Fig. 3b). The FEM calculations were consistent with the measurement results. This allows confirming the correctness of the assumptions adopted for the calculations. Fig. 5b shows the isotherm layout in the cross-section at the moment of heating termination. Due to the high thermal inertia of concrete [10], there was a slight increase in temperature in the middle part of the cross-section at the beginning of free cooling (c. 20–30 minutes). The 100°C and 200°C isotherms shifted up by about 10–15 mm on average and the 300°C isotherm by about 5 mm. The range of 400–1000°C isotherms did not increase significantly during cooling.

4.2. Wave velocity – cross measurement

Fig. 6 shows the results of measurements of the average ultrasonic wave velocity through subsequent layers of the beam cross-section. The values on the vertical axis were calculated by dividing the cross-section width by the wave travel time. Six measurements (two at each of three different points) were taken at every considered cross-section level. A good consistency of results was obtained.

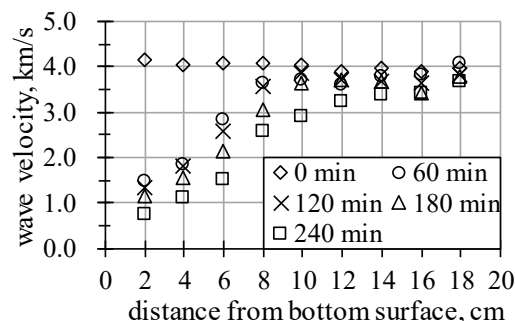

Fig. 6. Results of wave velocity measurements across the beam

The wave velocity obtained in the direct test on the unheated beam at different levels ranged from 3.90 to 4.15 km/s and the average value was 4.02 km/s.

In heated beams, the wave velocity was decreasing with higher concrete temperatures. This is clearly visible for distances from the bottom surface in a range 0–8 cm, in the beams heated for 60, 180 and 240 minutes. Only in the beam heated for 120 minutes, at 4 and 8 cm levels, the same result was obtained as in the beam heated for 60 minutes. For longer distances from the heated surface, the results start to stabilize:

- in a beam heated for 60 minutes – from a distance of 8 cm, which approximately corresponds to the position of the 100°C isotherm (see Fig. 5b),

- in a beam heated for 120 minutes – from a distance of 8 cm; isotherm $\sim 200^{\circ}\text{C}$,
- in a beam heated for 180 minutes – from a distance of 10 cm; isotherm $\sim 200^{\circ}\text{C}$,
- in a beam heated for 240 minutes – from a distance of 14 cm; isotherm $\sim 170^{\circ}\text{C}$.

The “stabilization point” of the results can be interpreted as a distance from the heated surface in which the concrete has not been damaged by high temperature.

4.3. Wave velocity – linear measurement

Fig. 7 shows the relationship between the time of ultrasonic wave passage in the near-surface concrete layer and the distance (x) between the transducers for the unheated beam. Average values of the wave travel time for different transmitter positions were plotted as a point diagram. A linear approximation of passage time dependence on the distance between the transducers was marked with a dashed line. Based on cotangent of this line tilt angle to the x -axis, an average ultrasonic wave velocity in unheated concrete was determined, $v_s = 3.24$ km/s. It is about 20% less than the velocity obtained in the direct measurements. Such occurrence is consistent with the results of other studies available in the literature, e.g. in the paper [17].

The lower value of wave velocity in the indirect test results from the lower energy of the ultrasonic pulse emitted perpendicularly to the transducer axis [21]. The wavefront location is less pronounced and can be recorded by the receiver with a delay. Moreover, in reality, the path of the wave during the linear measurement is longer than the distance x between the transducers measured in a straight line on the member surface. The ultrasonic wave emitted by the transmitter runs in a near-surface layer of concrete, diffracting around disturbances such as cracks and air voids, which extends the travelled distance.

Fig. 8 shows examples of results of measurements performed in a beam heated for 120 minutes. Similar results were observed in other beams.

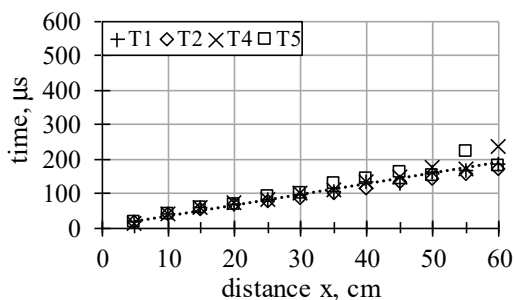

Fig. 7. Ultrasonic wave velocity in an unheated beam – linear measurement

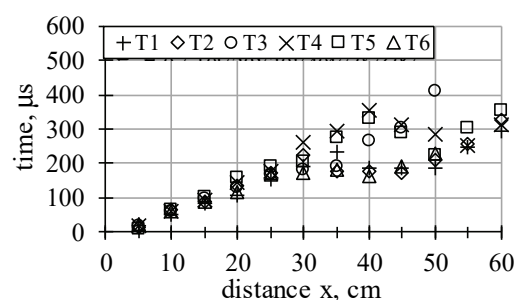

Fig. 8. Ultrasonic wave velocity in a beam heated for 120 minutes – linear measurement. T1-T6 – subsequent positions of the transmitter

For a relatively short distance between the transducers (up to about 25 cm) the spread of results is small. A trend line could be determined. Its tilt to the x -axis would be greater than that for the unheated beam (Fig. 7). This confirms that the wave velocity in heated concrete was lower than in unheated concrete (lower value of the cotangent of tilt angle to the x -axis).

For a larger distance between the transducers ($25 < x < 40\text{--}50$ cm), the results diverge. However, it can be seen that if the upper envelope of the results was to be considered in the $25 < x < 40\text{--}50$ cm range, it would approximately follow the trend line specified for the range: $5 < x < 25$ cm. This leads to the conclusion that a similar average wave velocity could be determined from the “upper” results as from the $5 < x < 25$ cm range. If a trend line was to be determined from the “lower” results between $25 < x < 40\text{--}50$ cm, the tilt would be small, roughly in accordance with the trend line as shown in Fig. 7 (unheated concrete).

A possible interpretation of the phenomenon described above is that in some measurements taken for a large distance between the transducers ($25 < x < 40\text{--}50$ cm), the wave ran through the concrete damaged by high temperature. In some other measurements (the “bottom” results), the wave found a path through places where the concrete was much less damaged or even not damaged at all., i.e. the travel time was shorter.

For an even greater distance between the transducers ($x > 50$ cm), all results converge again. Therefore, it can be concluded that for a sufficiently large distance x , the waves in all cases found a faster path.

Fig. 9–12 present a thickness estimation of the destroyed concrete layer in beams heated for 60, 120, 180 and 240 minutes. Distance-time diagrams for each of the six transmitter locations were plotted. The average (out of five measurements) time of wave passage, depending on the distance between transducers, was shown as a point diagram. The linear approximation of average wave velocity in the damaged concrete layer (v_d) was marked by a dashed line. However, this approximation was performed only in the range from 5 cm to x_0 , i.e. to the distance beyond which the diagram adopts a much smaller tilt to the horizontal axis. The results obtained for the distance $x > x_0$ were regarded as unreliable (see analysis of Fig. 8). The boxes below the particular diagrams in Fig. 9–12 give arbitrarily determined values:

- distance between the transducers (x_0) beyond which the relation $t(x)$ is not reliable,
- average wave velocity in damaged concrete (v_d) defined as the cotangent of the tilt angle of the dashed line to the x -axis.

Then, on the basis of Eq. (2.1), the thickness of the destroyed concrete layer (d_i) was determined. The calculated d_i values are given under the individual diagrams in Fig. 9–12. However, the v_s value

was not determined according to the recommendations [22] (see Fig. 1). As already explained above, the determination of velocity in undamaged concrete (v_s) based on Fig. 9-12 would be incorrect due to a variable, inconclusive wave passage for distances between the transducers larger than x_0 . The average wave velocity in unheated concrete calculated on the basis of Fig. 7 ($v_s = 3.24$ km/s) was inserted into Eq. (2.1).

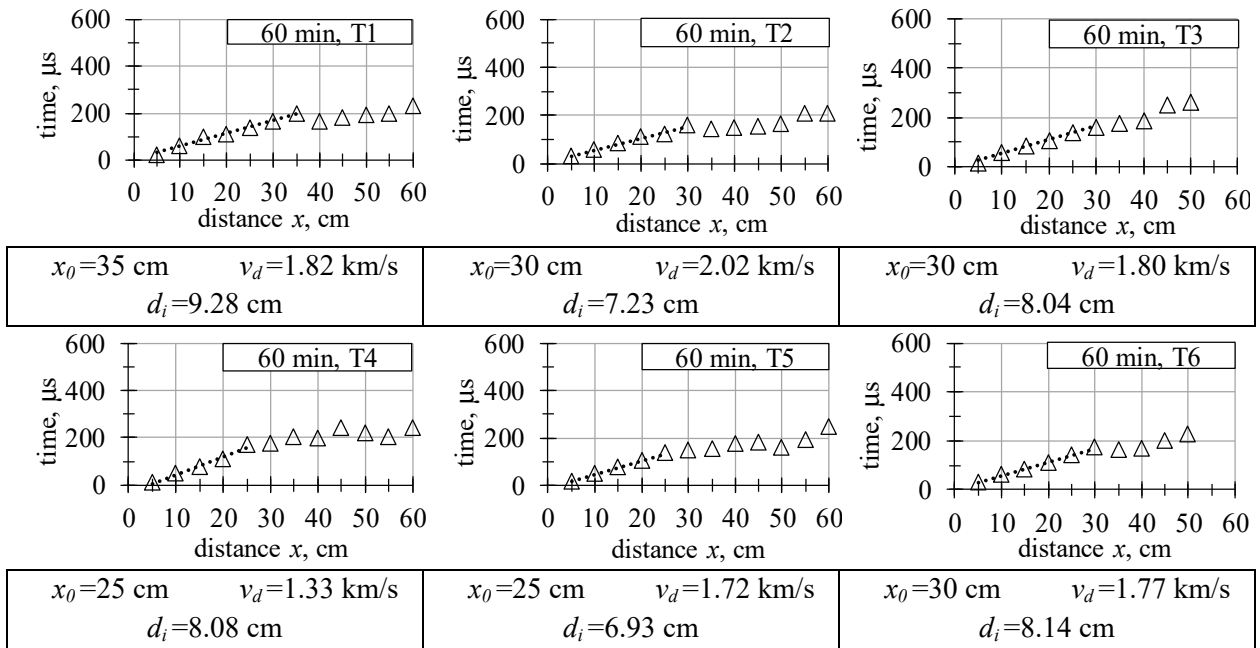

Fig. 9. Average ultrasonic wave velocity in a beam heated for 60 minutes – linear measurement

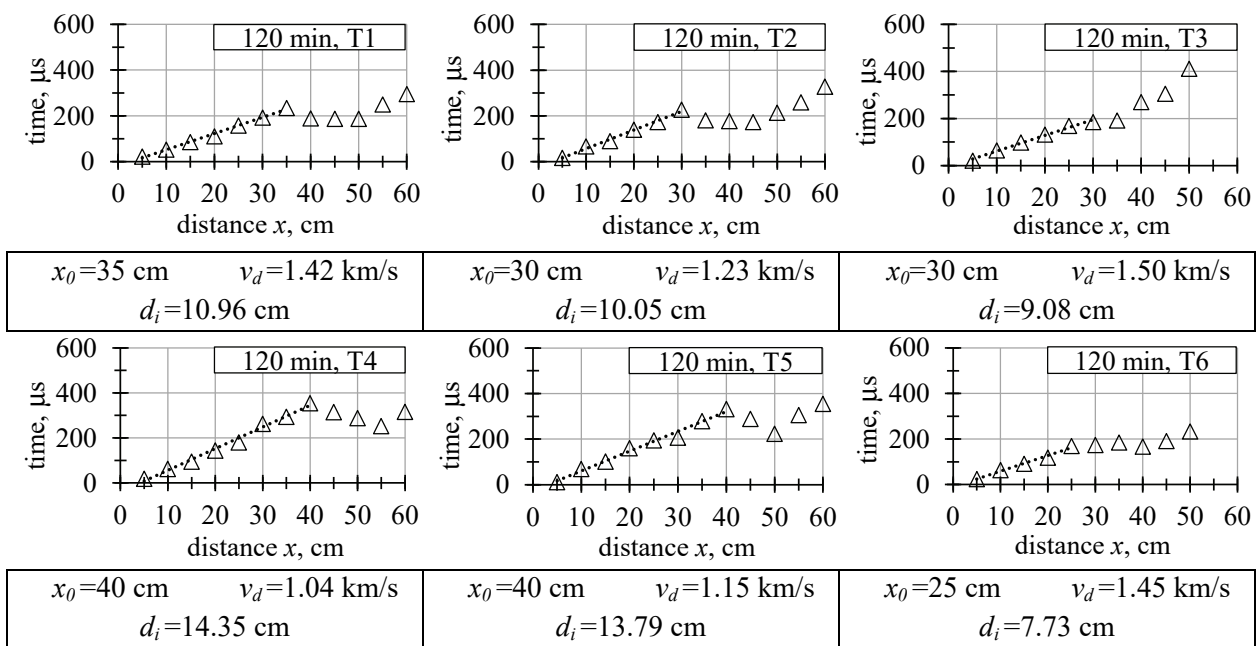

Fig. 10. Average ultrasonic wave velocity in a beam heated for 120 minutes – linear measurement

Table 1 presents the average values of the parameters specified under the particular diagrams in Fig. 9–12 and the coefficients of variation of these parameters. Additionally, the distances d_d determined on the basis of cross measurements (Fig. 7) and temperature values estimated on the basis of d_i (indirect measurement) and d_d (direct measurement) according to Fig. 5b are given.

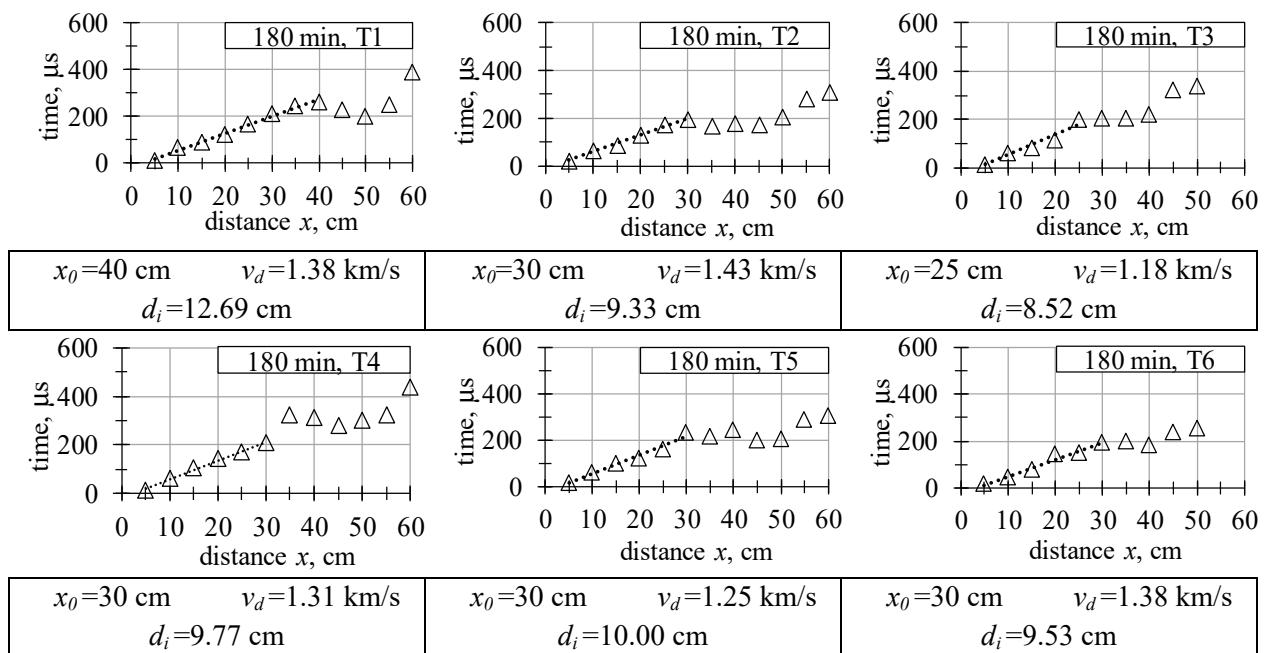

Fig. 11. Average ultrasonic wave velocity in a beam heated for 180 minutes – linear measurement

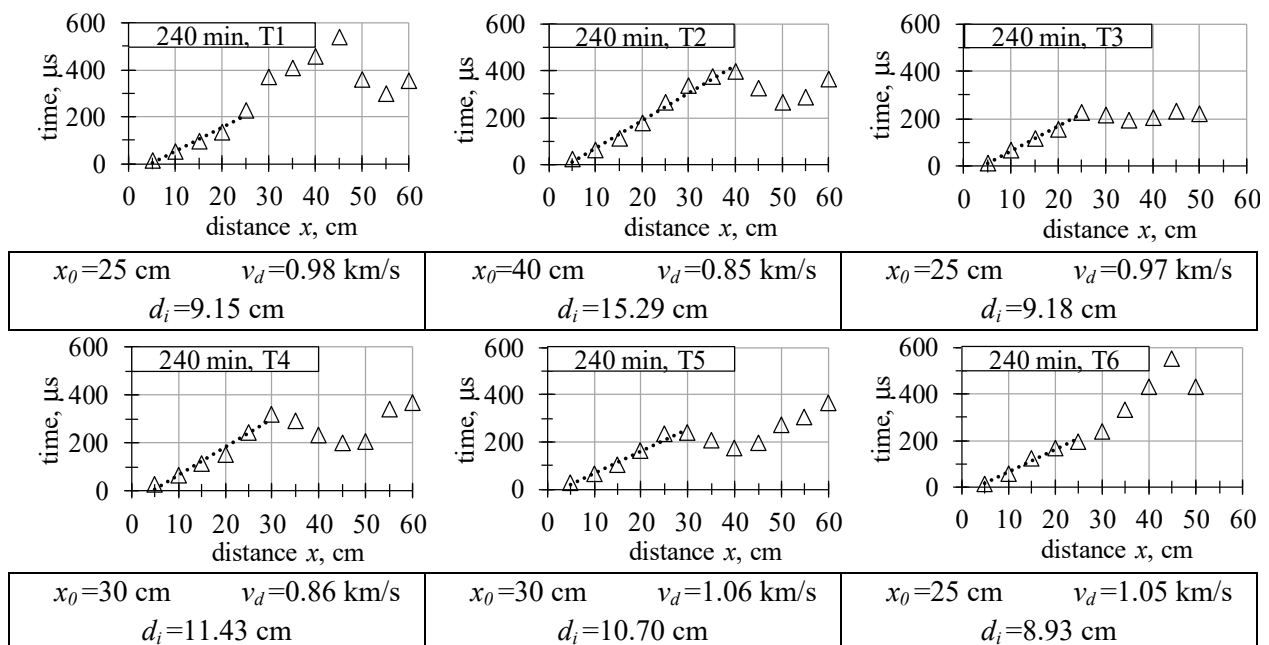

Fig. 12. Average ultrasonic wave velocity in a beam heated for 240 minutes – linear measurement

The indirect tests for each beam show quite a large scatter of results (coefficient of variation $CV_{di} > 10\%$). This may be caused by random disturbances of the wave passage induced by:

- significant degradation and roughness of the surface to which the transducers were applied,
- internal non-uniformity of concrete microstructure damaged by high temperature,
- unidentified local impediments occurring on the ultrasonic wave path in the tested member (e.g. large cracks, air voids).

Table 1. Comparison of damaged concrete layer thickness estimation by direct and indirect UPV test

Heating duration t [min]	Velocity		Distance		Depth Indirect measurement			Depth Direct measurement	
	v_d [km/s]	CV_{vd} [%]	x_0 [cm]	CV_{x_0} [%]	d_i [cm]	CV_{di} [%]	T [°C]	d_d [cm]	T [°C]
60	1.74	13	29.2	13	7.9	10	~100	8.0	~100
120	1.30	14	33.3	18	11.0	24	~130	8.0	~200
180	1.32	7	30.8	16	10.0	14	~200	10.0	~200
240	0.96	9	29.2	20	10.8	22	~230	14.0	~170

The average wave velocity in the unheated beam $v_s = 3.24$ km/s was inserted into Eq. (2.1) to calculate the d_i value. Therefore, the estimated depth d_i should refer to the location of concrete completely undamaged by a fire. This corresponds to the isotherm value (read from Fig. 5b) equal to about 100–230°C.

A qualitative consistency between indirect and (more reliable) direct test results can be concluded. In particular, practically identical values of estimated thickness of the destroyed concrete layer were obtained in these two tests for beams heated for 60 minutes (8 cm) and 180 minutes (10 cm). In beams heated for 120 and 240 minutes, much higher coefficients of variation of d_i and significant differences between direct and indirect measurements were observed. This may result from the above mentioned random factors.

The studies presented in this paper were performed on just a few members. In order to identify better the factors influencing the quality of indirect UPV test results, it is planned to continue the studies in the future. Repeatability of the results should be verified on a larger number of specimens. Such factors as compressive strength (including ordinary and high-performance concrete), aggregate type, concrete mix composition, and water content should be taken into consideration.

5. Conclusions

- For the assessment of concrete damage in a structure exposed to high temperature, only an indirect UPV method is appropriate.

After a fire, the concrete in the structure is usually non-uniform. The greatest concrete degradation occurs in the near-surface zone of the member cross-section. The direct (cross) measurement of the ultrasonic wave velocity would result in an average value for the entire thickness of tested members. These results would be overestimated in relation to the actual concrete condition in the near-surface zone.

- Due to surface roughness, exponential transducers should be used for ultrasonic measurements of concrete after a fire.

From a practical point of view, a method for testing structures after a fire is only useful if, in a relatively short time (e.g. several hours), results can be obtained in as many places as possible (e.g. at least 20–30). Therefore, it is reasonable not to use time-consuming precise grinding of concrete surface in the areas to which the transducers are applied. When using cylindrical transducers on a rough surface, overstated and highly scattered results of wave velocity estimation should be expected.

- The principles of the ultrasonic test described in the report [22] do not fully correspond to the state of concrete in structures after a fire.

The method assumes that a damaged concrete layer with uniform mechanical properties occurs at the surface exposed to high temperature (Fig. 1) [28]. In fact, after a fire, concrete in the external layer of the member cross-section has variable mechanical properties, depending on the distance from the heated surface. The boundary between damaged and undamaged concrete is not sharp.

- In the studies described in this paper, the method proposed in the report [22] was modified by taking slightly different values of parameters inserted into Eq. (2.1) than those recommended:

- the wave velocity in damaged concrete (v_d) was estimated from linear measurements taken according to the recommendations [22], but only in the range of distance between the transducers from 5 cm to the value (x_0) for which the obtained distance-time relationships were reliable, i.e. the results were arranged linearly in the diagram,
- the distance between the transducers at which the wave travel time in damaged concrete was equal to that in undamaged concrete (x_0) was determined as described above,

- the wave velocity in undamaged concrete (v_s) was estimated from the linear measurements of concrete that was not heated; in practice, it will always be possible to perform such a test in a place where the structure was not exposed to fire; the results obtained by the authors showed that it is impossible to estimate reliably the wave velocity in undamaged concrete only on the basis of distance-time diagrams for heated members, because the boundary between damaged and undamaged layer is not sharp.
- Although the tests were performed on just a few members, it can be stated that the results confirmed qualitatively the usability of the described above modification of the method proposed in the paper [28].

In order to identify better the factors influencing the quality and repeatability of this method, the studies should be continued on a larger number of specimens.

- The initially estimated thickness of the destroyed concrete layer corresponds to the distance from the heated surface to the location where the concrete temperature did not exceed 230°C.
- The modification of the method described in the report [22] may be useful for quick estimation of the depth in a structural member cross-section at which undamaged concrete occurs.

It can also be cautiously concluded that if a different wave propagation velocity in undamaged concrete (v_s), e.g. corresponding to that in concrete heated to a specified temperature (e.g. 500°C) is inserted into Eq. (2.1), then the depth in the cross-section at which this temperature occurred could be estimated.

References

- [1] K.R. Kordina, “Design of concrete buildings for fire resistance”, Chapter 6 in: Structural concrete. Textbook on behaviour, design and performance. Second edition. Vol. 4. fib bulletin 54: pp. 1–36, 2010.
- [2] EN 1992-1-2:2004. Eurocode 2: Design of concrete structures - Part 1-2: General rules – Structural fire design.
- [3] U. Schneider, „Behaviour of Concrete under Thermal Steady State and Non-Steady State Conditions“, Fire and Materials 1(3): pp. 103–115, 1976. <https://doi.org/10.1002/fam.810010305>
- [4] Q. Ma, R. Guo, Z. Zhao, Z. Lin, K. He, “Mechanical properties of concrete at high temperature – A review”, Construction and Building Materials 93: pp. 371–383, 2015. <https://doi.org/10.1016/j.conbuildmat.2015.05.131>
- [5] W. Jackiewicz-Rek, T. Drzymała, A. Kuś, M. Tomaszewski, “Durability of High Performance Concrete (HPC) Subject to Fire Temperature Impact”. Archives of Civil Engineering, 62(4): pp. 73–94, 2016. <https://doi.org/10.1515/ace-2015-0109>
- [6] fib Bulletin 38/2007, “Fire design for concrete structures – materials, structures and modelling. State-of-art report”, International Federation for Structural Concrete (fib), April 2007.
- [7] R. Kowalski, “Calculations of reinforced concrete structures fire resistance”, Architecture Civil Engineering Environment. Journal of the Silesian University of Technology, Vol. 2, No. 4/2009, pp. 61–69.
- [8] EN 1991-1-2:2002. Eurocode 1: Actions on structures. Part 1-2: General actions. Actions on structures exposed to fire
- [9] R. Kowalski, „On the identification of the reference isotherm in the simplified analysis of R/C members in fire“, Studies and Researches. Annual Review of Structural Concrete Vol. 30, Ed. by Politecnico di Milano and Italcementi, Starrylink Editrice (Brescia, Italy), pp. 281–306, 2010.

- [10] R. Kowalski, "Temperature distribution in R/C cross-section subjected to heating and then freely cooled down in air", Chapter 9 in: Benchmark Studies. Experimental Validation of Numerical Models in Fire Engineering. CTU Publishing House, Czech Technical University in Prague, pp. 107–122, 2014.
- [11] R. Kowalski, M. Abramowicz, P. Chudzik, "Reaction of RC Slabs Cross-Sections to Fire. Calculation of Simplified Substitute Temperature Loads Induced by an Unsteady Heat Flow". Proceedings of International Conference: Applications of Structural Fire Engineering, Dubrovnik 2015. CTU Publishing House, Czech Technical University in Prague, pp. 214–219, 2015.
- [12] R. Kowalski, J. Wróblewska, "Application of a sclerometer to the preliminary assessment of concrete quality in structures after fire", Archives of Civil Engineering 64(4): pp. 171–186, 2018. <https://doi.org/10.2478/ace-2018-0069>
- [13] G.A. Khoury, "Compressive strength of concrete at high temperatures: a reassessment", Magazine of Concrete Research 44(161): pp. 291–309, 1992. <https://doi.org/10.1680/mac.1992.44.161.291>
- [14] V. Kodur, „Properties of concrete at elevated temperature“, ISRN Civil Engineering 2014: pp. 1–15, 2014. <http://dx.doi.org/10.1155/2014/468510>
- [15] R. Kowalski, P. Król, "Experimental Examination of Residual Load Bearing Capacity of RC Beams Heated up to High Temperature", Sixth International Conference Structures in Fire, Michigan State University, East Lansing, Michigan, USA, Proceedings edited by V.K.R. Kodur and J.M. Franssen, DEStech Publications Inc., pp. 254–261, 2010.
- [16] R. Kowalski, "The effects of the cooling rate on the residual properties of heated-up concrete", Structural Concrete. Journal of the *fib* 8(1): pp. 11–15. 2007.
- [17] I. Hager, T. Tracz, K. Krzemień "The usefulness of selected non-destructive and destructive methods in the assessment of concrete after fire", Cement Lime Concrete 3/2014: pp. 145–151, 2014.
- [18] R. Felicetti, "Assessment of fire damage in concrete structures: New inspection tools and combined interpretation of results", 8th International Conference on Structures in Fire, Shanghai, China, pp. 1111–1120, 2014.
- [19] P. Knyziak, R. Kowalski, R. Krentowski, "Fire damage of RC slab structure of a shopping center", Engineering Failure Analysis 97: pp. 53–60, 2019. <https://doi.org/10.1016/j.engfailanal.2018.12.002>
- [20] J. Wróblewska, R. Kowalski, "Assessing concrete strength in fire-damaged structures", Construction and Building Materials 254: pp. 119–122, 2020. <https://doi.org/10.1016/j.conbuildmat.2020.119122>
- [21] EN 12504-4:2004. Testing concrete. Determination of ultrasonic pulse velocity.
- [22] ACI 228.2R-98. Nondestructive test methods for evaluation of concrete in structures.
- [23] L.X. Xiong, "Uniaxial Dynamic Mechanical Properties Of Tunnel Lining Concrete Under Moderate-Low Strain Rate After High Temperature", Archives of Civil Engineering 61(2): pp. 35–52, 2015. <https://doi.org/10.1515/ace-2015-0013>
- [24] I. Hager, H. Carré, "Ultrasonic pulse velocity investigations on concrete subjected to high temperature with the use of cylindrical and exponential transducers", 7th International Conference on Structures in Fire, Zurich, Switzerland, pp. 805–814, 2012.
- [25] P.F. Castro, A. Mendes Neto, "Assessing strength variability of concrete structural elements", The 8th International Conference of the Slovenian Society for Non-Destructive Testing Application of Contemporary Non-Destructive Testing in Engineering, Portorož, Slovenia, pp. 123–130, 2005.
- [26] A. Mariak, K. Wilde, "Multipoint Ultrasonic Diagnostics System Of Prestressed T-Beams", Archives of Civil Engineering 60(4): pp. 475–491, 2015. <https://doi.org/10.2478/ace-2014-0032>
- [27] J. Jaskowska-Lemańska, J. Sagan, "Non-Destructive Testing Methods as a Main Tool Supporting Effective Waste Management in Construction Processes", Archives of Civil Engineering 65(4): pp. 263–276, 2019. <https://doi.org/10.2478/ace-2019-0059>
- [28] H.W. Chung, K.S. Law, "Assessing fire damage of concrete by the ultrasonic pulse technique", Cement, Concrete and Aggregates (ASTM) 7(2): pp. 84–88, 1985.
- [29] EN 1992-1-2:2004. Eurocode 2. Design of concrete structures. General rules. Structural fire design.
- [30] R. Kowalski, "Mechanical properties of concrete subjected to high temperature", Architecture Civil Engineering Environment 3(2): pp. 61–70, 2010.
- [31] O. Abraham, X. Dérobert, "Non-destructive testing of fired tunnel walls: the Mont-Blanc Tunnel case study", NDT&E International 36: pp. 411–418, 2003.
- [32] M. Colombo, R. Felicetti, "New NDT techniques for the assessment of fire damaged concrete structures", 4th International Workshop *Structures in Fire*, Aveiro, Portugal, pp. 721–734, 2006.
- [33] W. Wuryanti, "Determination residual strength concrete of post-fire using ultrasonic pulse velocity", IOP Conference Series Materials Science and Engineering 620: pp. 12–64, 2019. <https://doi.org/10.1088/1757-899X/620/1/012064>
- [34] U. Dilek, M.L. Leming, "Comparison of pulse velocity and impact-echo findings to properties of thin disks from a fire damaged slab", Journal of Performance of Constructed Facilities 21(1): pp. 13–21, 2007. [https://doi.org/10.1061/\(ASCE\)0887-3828\(2007\)21:1\(13\)](https://doi.org/10.1061/(ASCE)0887-3828(2007)21:1(13))
- [35] J. Franssen, "User's Manual for SAFIR 2016 A Computer Program for Analysis of Structures Subjected to Fire", University of Liege, Belgium, 2016.

Wykorzystanie metody ultradźwiękowej do oceny betonu w konstrukcjach po pożarze

Słowa kluczowe: beton, wysoka temperatura, metoda ultradźwiękowa, pomiar liniowy, głowice eksponencyjne

Streszczenie:

W artykule przedstawiono opis i wyniki badań mających na celu sprawdzenie przydatności metody ultradźwiękowej do oceny jakości betonu w konstrukcjach po pożarze.

W warunkach pożarowych w przekroju elementów żelbetowych występuje niestabilny przepływ ciepła. Powierzchnia elementów nagrzewa się szybciej niż ich wnętrze. Największa degradacja betonu zachodzi w strefie przypowierzchniowej. W związku z tym podczas oceny konstrukcji po pożarze szczególnie istotne jest określenie grubości zewnętrznej warstwy przekroju elementu, w której beton jest na tyle uszkodzony, że należy go uznać za zniszczony.

Metoda ultradźwiękowa jest znormalizowana i powszechnie stosowana do badania betonu *in situ*. Mierzony jest czas przejścia fali ultradźwiękowej w betonie pomiędzy, umieszczonymi na jego powierzchni, głowicą nadawczą i odbiorczą betonoskopu. W warunkach zwykłych na podstawie prędkości fali można oszacować wytrzymałość betonu na ściskanie, stosując zależności korelacyjne.

Metoda ultradźwiękowa może być również dobrym wskaźnikiem stopnia uszkodzeń betonu po pożarze. W efekcie procesów termomechanicznych i chemicznych zachodzących w betonie ogrzewanym do wysokiej temperatury maleje jego moduł Younga oraz zmniejsza się ilość zawartej wody. Powoduje to zmniejszenie prędkości rozchodzenia się fali ultradźwiękowej w betonie. Do oceny uszkodzeń elementów konstrukcji po pożarze (w których beton ma niejednorodne właściwości) zasadne jest stosowanie pośredniej metody ultradźwiękowej. Obie głowice betonoskopu przykładają się do tej samej powierzchni elementu, co umożliwia zbadanie betonu w strefie przypowierzchniowej.

W wytycznych *ACI 228.2R-98. Nondestructive test methods for evaluation of concrete in structures* [22] opisano wykorzystanie pośredniego badania ultradźwiękowego do oszacowania zasięgu uszkodzeń betonu w ogrzewanym elemencie. Zakłada się, że w rozpatrywanym elemencie można wydzielić przypowierzchniową warstwę betonu o gorszych parametrach mechanicznych (warstwę zniszczoną) oraz beton wewnątrz przekroju, nieuszkodzony przez oddziaływanie wysokiej temperatury. Mierzy się czas przejścia fali ultradźwiękowej dla kolejno zwiększanych odległości pomiędzy głowicami. Na wykresie zależności czasu (t) przejścia fali od dystansu (x) między głowicami powinno wystąpić charakterystyczne załamanie dla odciętej oznaczonej x_0 . Jest to odległość między głowicami, dla której czas przejścia fali w warstwie powierzchniowej (mniejsza prędkość fali v_d w betonie zniszczonym) jest równy czasowi przejścia fali przez głębsze warstwy przekroju (większa prędkość fali v_s w betonie nieuszkodzonym). Należy zauważyć, że w rzeczywistości w elementach narażonych na warunki pożarowe beton w warstwie przypowierzchniowej ma zmienne parametry mechaniczne, zależne od temperatury, jakiej był poddany, a więc zależne od odległości od powierzchni ogrzewanej. Nie można określić ostrej granicy między betonem zniszczonym, a nieuszkodzonym. Granica ta jest „rozmyta” i może być rozpatrywana jedynie jako umowna.

We własnych badaniach eksperymentalnych autorów cztery belki żelbetowe o przekroju 160×200 mm poddano działaniu wysokiej temperatury z jednej strony (od spodu) przez 60, 120, 180 i 240 minut. Jedna belka była nieogrzewana. Boczne powierzchnie elementów zostały zaizolowane termicznie, dzięki czemu zagwarantowano jednokierunkowy przepływ ciepła w przekroju. W wyniku przeprowadzonych obliczeń MES uzyskano mapy pól temperatury w zależności od czasu ogrzewania. Otrzymano dobrą zgodność pomiarów temperatury w przekroju ogrzewanym z wartościami obliczonymi.

Do badań ultradźwiękowych wykorzystano betonoskop z głowicami eksponencyjnymi o punktowym kontakcie z badanym materiałem. Umożliwiło to przeprowadzenie pomiarów bez konieczności szlifowania powierzchni betonu zdegradowanej w wyniku oddziaływania wysokiej temperatury oraz bez stosowania środka sprzęgającego. Przeprowadzono dwa rodzaje badań ultradźwiękowych:

- pomiary bezpośrednie (wskroś), w których mierzono czas przejścia fali ultradźwiękowej w poprzek przekroju belki (równoległe do układu izoterm), umieszczając głowice betonoskopu na przeciwległych, bocznych powierzchniach elementu – badanie referencyjne,
- pomiary pośrednie (liniowe), w których mierzono czas przejścia fali w warstwie przypowierzchniowej na spodzie belki, zmieniając dystans między głowicami w zakresie od 5 do 60 cm (skokowa zmiana pozycji głowicy odbiorczej co 5 cm).

W badaniach bezpośrednich zaobserwowano stabilizowanie się wartości mierzonej prędkości fali ultradźwiękowej w pewnej odległości od spodu belek poddanych działaniu wysokiej temperatury. Odległość ta rosła wraz z czasem ogrzewania i wynosiła od 8 do 14 cm, co odpowiadało położeniu izotermy $\sim 100 - 200^\circ\text{C}$. „Miejsce stabilizowania” się wyników można interpretować jako położenie betonu, który nie został uszkodzony na skutek ogrzewania.

W badaniach pośrednich przeprowadzonych na belce nieogrzewanej uzyskano liniową zależność pomiędzy odległością między głowicami (x) a czasem przejścia fali ultradźwiękowej. Pozwoliło to na określenie średniej prędkości fali w betonie nieogrzewanym (v_s). W badaniach belek ogrzewanych stwierdzono w przybliżeniu stałą prędkość fali ultradźwiękowej dla odległości pomiędzy głowicami $x < \sim 25$ cm oraz stosunkowo duży rozrzut wyników dla odległości w przedziale $\sim 25 < x < 40 - 50$ cm. Z tego powodu wprowadzono modyfikacje metody opisanej w wytycznych [22], wstawiając do wzoru na grubość zniszczonej warstwy betonu:

$$d_i = \frac{x_0}{2} \sqrt{\frac{v_s - v_d}{v_s + v_d}}$$

- prędkość fali w betonie uszkodzonym (v_d), oszacowaną na podstawie pomiarów liniowych wykonanych wg zaleceń [15], ale tylko w przedziale odległości między głowicami od 5 cm do wartości (x_0), przy której zależność pomiędzy tą odległością a czasem przejścia fali była w przybliżeniu liniowa,
- odległość między głowicami (x_0), przy której czas przebiegu fali w betonie uszkodzonym (warstwa przypowierzchniowa) jest równy czasowi przebiegu w betonie nieuszkodzonym (głębsze warstwy przekroju), określoną wg opisu powyżej,
- prędkość fali w betonie nieuszkodzonym (v_s), oszacowaną na podstawie pomiarów liniowych betonu, który nie był ogrzewany; w praktyce wykonanie takiego badania zawsze będzie możliwe w miejscu, w którym konstrukcja nie była narażona na działanie pożaru.

Można stwierdzić jakościową zgodność wyników pomiarów pośrednich i referencyjnych pomiarów bezpośrednich. Uzyskane wyniki badań potwierdziły jakościowo zasadność opisanej wyżej modyfikacji metody zaproponowanej w [22]. Wstępnie oszacowana grubość zniszczonej warstwy betonu odpowiadała odległości od powierzchni ogrzewanej, na której temperatura betonu zawierała się w przedziale od 100 do 230°C. Zaproponowana w artykule zmodyfikowana metoda [22] może być zatem przydatna do szybkiego oszacowania odległości od powierzchni ogrzewanej, na której występuje beton nieuszkodzony.

Received: 2020-12-20, Revised: 2021-02-09