

A TECHNOLOGY OF UTILIZATION IN ROAD CONSTRUCTION
OF OIL SLUDGE RESULTING FROM THE SEWAGE TREATMENT
IN THE POLISH OIL CONSORTIUM „ORLEN” JOINT STOCK
COMPANY (PKN ORLEN S.A.) IN PŁOCK

BRONISŁAW BARTKIEWICZ, IWONA OBIERAK

Warsaw University of Technology, Environmental Engineering Faculty, Institute of Water Supply and Water Engineering
ul. Nowowiejska 20, 00-653 Warszawa, Poland

Keywords: petrochemical sludge utilization, road construction material.

TECHNOLOGIA UTYLIZACJI W BUDOWNICTWIE DROGOWYM ZAOLEJONYCH
OSADÓW Z OCZYSZCZANIA ŚCIEKÓW W PKN ORLEN S.A. W PŁOCKU

Przy wstępnym oczyszczaniu ścieków z zakładów rafineryjno-petrochemicznych powstają płynne osady ściekowe o wysokim uwodnieniu i tylko nieco mniejszym procencie węglowodorów. Osady te są gromadzone w bezodpływowych zbiornikach, gdyż nie ma dla nich zastosowania. Niniejsze badania miały na celu w pierwszym etapie zamianę osadów o charakterze płynnym na osad o konsystencji stałej (produkt) przez dodanie wapna palonego, a następnie utylizację tak wytworzonego produktu w budownictwie drogowym jako kilkuprocentowego dodatku do dolnych warstw drogi. Drugi etap badań dotyczył oceny wpływu produktu wbudowanego w podłoże dróg lub placów na środowisko wód podziemnych i powierzchniowych przez analizę zmian składu chemicznego tych wód w bezpośrednim sąsiedztwie zrealizowanych doświadczalnych odcinków dróg. Przy zachowaniu odpowiednich proporcji pomiędzy produktem i naturalnym materiałem drogowym wpływ ten mieści się w granicach dopuszczalnych prawem.

Summary

Processes applied for preliminary treatment of wastewater from refineries and petrochemical plants create the oily sludge, containing high percentage of water and only a bit less of hydrocarbons. This sludge is collected in storage tanks, because no application for it can be found. Our researches had as a first step the aim to convert this fluid sludge into solid substance (product) by adding of quicklime and then utilize the product in the road construction as a bottom layer of the road. The product should be added in the amount of a few percent comparing to the rest of soil. The second step of the research was an assessment of an impact of the product used for construction of experimental sections of roads and squares on environment by monitoring of surface and ground water quality in their vicinity. If the contribution of the product in total amount of the road material is less than 8% the influence is kept under limits.

INTRODUCTION

The technologies applied for crude oil processing cause emission of toxic substances, both liquid and solid, to the environment. For instance, the process of crude oil distillation is a source of relatively large amount of SO₂, H₂S, CO₂ and hydrocarbons. A catalytic

cracking relates to the emission of an increased amount of NO_x , CO , CO_2 , dust and sludge. Installations for reforming cause high contamination of wastewater, air and soil with aromatic hydrocarbons. The sewage treatment plants are the main source of hydrocarbons emission and oily sludge with high concentration of water [9].

SOURCES, QUANTITY AND QUALITY OF THE REFINERY WASTEWATER SLUDGE

In the refineries the water is used for the fuel conditioning (desalination, oil-in water emulsion destabilization), steam stripping from outlets and sewage, steam production, cooling, washing and cleaning of products, for sanitary and fire-fighting purposes. A plant with an annual processing capacity of 12 Millions Mg of crude oil produces approx. 800 m³/h of heavily polluted sewage [1].

Technological sewage is contaminated with such substances as: hydrocarbons, phenols, heavy metals, sulfides, ammonia, dissolved salts and suspended matter.

Refinery wastewater treatment plants work using a three-stage treatment system, and at each stage a significant amount of the sludge is produced. Mechanical treatment is the first stage. It is conducted in API gravitation separators, disk separators, vessel separators and others. Its aim is to recover the free oils and remove heavy pollutants accumulated at the bottom of the separator. At the second stage of the treatment a flocculation and floatation with the use of compressed air take place. Dispersed oils and fine solid impurities are removed, creating the oily sludge. The third stage of the wastewater treatment involves biological processes, in result of which the biological sludge is produced [1].

According to the CONCAWE (The Oil Company's European Organization for CONservation of Clean Air and Water in Europe) there are three groups of sludge from refineries:

- sludge without, or with low content of hydrocarbons, e.g. sludge resulting from the water conditioning or biological wastewater treatment;
- sludge with the level of hydrocarbons content below 10%, e.g. sludge resulting from the mechanical and chemical wastewater treatment;
- other, with significant content of hydrocarbons [9].

TECHNOLOGIES FOR SLUDGE TREATMENT AND UTILIZATION

Legislation on the waste management

The main aim of sludge processing is nuisance abatement related to the sludge disposal. The basic rules of the waste management are: minimizing the sludge amount, recycling or recovery into usable, non toxic materials or utilization of waste (incineration, biodegradation, storage). This hierarchy of rules is determined by the Council Directive 75/442/EEC on waste, providing obligation to recover or dispose waste without threat to the human health and without harming the environment [2]. In Poland, solutions consistent with the European Union directives were introduced by the Waste Act of April 27, 2001 [16].

Sludge dewatering

Dewatering of sludge is a process of water removal in order to lessen the sludge volume. There are two basic methods of sludge dewatering: natural and mechanical. Natural dewatering takes place at the settling ponds. Water removal is done by filtration and

evaporation. Drainage water flows to the wastewater treatment system [12].

Mechanical dewatering of sludge is a quicker method of the sludge volume reduction, and additionally, it enables the recovery of oil products. This process takes place in sludge centrifuges and at presses. For dewatering of oil sludge three phase centrifuges are suitable, which separate solid phase from liquid one as well as oils from the water.

As a result of dewatering in sludge centrifuges, the content of a dry matter in sludge can be increased to 20–40% and dewatering at the filter presses increases a content of a dry matter even to 30–50% [6, 9].

Thermal utilization of the sludge

Thermal methods of sludge utilization result in maximal reduction of the sludge volume and recovery of a thermal energy. Incineration is a safe method, providing the high degree of decomposition of contaminants in the industrial waste, including the hazardous waste such as oil sludge. The FCB (Fluid Bed Combustion) installations are successfully used in Poland for sludge incineration, e.g. in PKN Orlen S.A. in Płock and in the Gdańsk Refinery [7].

Solidification of the sludge

The solidification processes alter hazardous sludge to the solid substances, which are inert or less hazardous to the environment. More and more frequently this method is also applied in Poland.

The process of sludge solidification is based on treating sludge with a binding material in order to limit a mobility of pollutants and facilitate sludge disposal. Many techniques of solidification have been developed so far, among others those with the use of cement, lime, fly ash, thermoplastic material and polymers. The most effective way of solidification is adding materials, which bound chemically pollutants contained in sludge [13, 17].

The solidification processes most frequently involve the use of cement. Substances contained in the sludge contaminated with hydrocarbons may have negative influence on reactions of setting and hardening of the cement [8]. It is proved that the salts of manganese, tin, cooper and lead negatively influence the cement strength. A contamination of waste with sulfates is also unfavorable, but in that case sulfate-resistant cement or different additives can be used.

In Poland, a technology for solidification of hazardous waste containing a high level of organic substances has been developed. Apart from cement, diatomaceous earth and asphalt are used. A good immobilizing efficiency of these technologies has been proved by the results of the analyses of the water extracts and the strength of solidified mass after defined time of stabilization [15].

More and more frequently commercial additives improving stabilization effect are put on the market. The Funderburk & Associates Company proposes a technology of solidification with the use of cement or fly ash and an additive called Chloranan, and the WASTECH, INC Company with the use of additive called SuperSet®.

Sludge mixed with cement gives a poor quality concrete, which can be safely disposed in the form of properly shaped blocks. However, a proper selection of the binding material gives a product which can be used for building or road-making purposes: as slabs and briquettes, concrete fences or kerbstones [12].

The Center of Hazardous Materials Research in the USA has developed a technology for destruction of hazardous organic substances with simultaneous stabilization of metals

and ions of metals (it can be applied for soil and sludge contaminated with organic substances and heavy metals). This technology comprises reaction of contaminated liquids, soil and sludge with elementary sulfur in higher temperature. At the same time, a conversion of heavy metals to sulfides, which are more resistant to leaching, takes place [3].

A simple method of sludge solidification is processing with the use of quick lime [14]. This method consists of mixing the sludge, mostly containing 60–70% of water, with quick lime (CaO). Lime reacts exothermically with water. During this process a considerable part of water evaporates and a powder-like or granulated product is obtained. The final product is physically and chemically stable, hydrophobic and with a good oil absorption. A product, after 10 minutes of stabilization can be used as a sealing material, material for road, foundations, tanks and embankments construction.

AIM OF THE WORK

The aim of that work is to find a simple method for converting fluid wastewater sludge into solid substance (product) due to addition of quicklime and then utilize the product, mixed with natural soil, in the road construction as a bottom layer of the road.

The second step of the research was an assessment of an impact of the product added by construction of experimental sections of roads and squares on environment by monitoring surface and ground water quality in their vicinity before and after constructing the road. Because the environmental concern is one of the barriers to the wide-ranging utilization of the oil sludge solidification product in road construction, it is important to identify all negative impacts of the product on the environment.

MATERIALS AND METHODS

Raw material characterization

The object of investigations was the oil sludge from mechanical and physicochemical treatment of refinery wastewater from the Water and Wastewater Department of PKN Orlen S.A. in Płock. The oil sludges are classified as wastes resulting from the crude oil processing (e.g. refining) and coded as 05 01 09 – sludge containing hazardous substances from industrial wastewater treatment plant [11].

The sludge is characterized by a significant content of water and relatively lower content of hydrocarbons (see Table 2), comparing to the other refinery and petrochemical sludge.

Methods

The oil sludge and the product of sludge stabilization were subjected to chemical analyses and a leaching test. Different techniques adopted for characterization of the oil sludge and the products are given below:

- An analysis of sludge and the product compositions were carried out according to the Polish Standards Methods (see References).
- Analyses of heavy metals were performed by Flame Atomic Absorption Spectrometry using an AAS, Solar 919.
- Water extracts were prepared in compliance with Polish Standard Method PN-97/Z-15009 for the classification of waste (quality control).

RESULTS AND DISCUSSION

In the following, the results of the determination of chemical composition of the oil sludge and the product as well as the pollutants concentration in the extracts are presented. The results of the analyses are compared with the correspondent limits imposed by the regulations, when available.

Composition of oil sludge

Sludge samples for analyses were taken from different places of a storage tank from the Water and Wastewater Department of PKN Orlen S.A. in Płock. Results of the analyses are presented in Table 1.

Table 1. Composition of sludge from the Water-and-Wastewater Department of PKN Orlen S.A. in Płock

Parameters	Sample			
	Maximal thickening	Average thickening	Minimal thickening	Av. from the whole depth
Moisture, %	30.9	79.5	92.8	73.0
Total solids, %	69.1	20.5	7.2	27.0
Total solids, fixed, %	25.9	68.8	63.0	63.5
Total solids, volatile, %	74.1	31.2	37.0	36.5

A great differentiation in a sludge hydration in the whole volume of tank was discovered, depending on a deposition place. Fluctuations reach 300%. A sample of maximal thickened sludge contains almost 70% of a dry matter. A sample of minimal thickened sludge is characterized by the high hydration containing only 7% of a dry matter.

Taking this into account, the big differences in a demand for quick lime to convert the fluid sludge into a product may occur. In relation to this, it is necessary to know the average sludge composition before processing it in a full-scale installation. For these purpose five samples of five kilograms each were taken from different parts of the storage tank and mixed in the lab. A composition of the sludge after mixing is provided in Table 2.

After mixing the sludge, water content exceeds 50%. A dry matter consists in one third of organic substances, most of which are hydrocarbons. Additionally, the sludge contains approx. 10% of calcium and a few heavy metals; of which iron, vanadium, zinc and nickel occur in the highest concentration.

Table 2. Composition of the averaging sludge from the Water-and-Wastewater Department of PKN Orlen S.A. in Płock

Parameters	Concentrations
Moisture, %	54.8
Total solids, %	45.2
Total solids, fixed, %	66.3
Total solids, volatile %	33.7
Sulphur, mg S_{SO_4} /kg _{ts}	66.4
Calcium, mg Ca/kg _{ts}	110480
Iron, mg Fe/kg _{ts}	8400
Zinc, mg Zn/kg _{ts}	504
Vanadium, mg V/kg _{ts}	1100
Nickel, mg Ni/kg _{ts}	277
Copper, mg Cu/kg _{ts}	140
Lead, mg Pb/kg _{ts}	170
Chromium, mg Cr/kg _{ts}	60
Cadmium, mg Cd/kg _{ts}	13
Oil and grease, %	36.0
Hydrocarbons, %	22.5

Solidification experiments with a different quick lime to sludge ratio

Under laboratory conditions the tests of the influence of quicklime (CaO) to oil sludge ratio on the effect of solidification were carried out. A product was received from sludge containing 55% of water, with the application of lime in the following percentages by weight: 10%, 25%, 30% and 35%. Characterization of the received products is presented in Table 3.

By increasing a dose of CaO a temperature of reaction is increased, beginning from the temperature of 42°C at 10% dose of lime to 99°C at 30% and 35% doses. The increase of temperature results in a rapid evaporation of water and in a hydration decrease. Application of 25% of quicklime to the wet sludge decreases its hydration twice. The greater the dose of lime, the lower the hydration. A mineral content in a product is very high comparing to the sludge, and it increases to 90% when the ratio of lime to the solidified sludge amounts approx. 30%. Owing to that a product is physically stable. Products are characterized by a lower concentration of heavy metals comparing to the sludge and decreased hydrocarbons concentration – from about 20% in the sludge to below 5% in a product stabilized with 30% addition of the lime.

The solidification experiments were carried out to process the oil sludge into an applicable construction material. On the basis of water contents analyses (see Table 3) and observations of the structure of a product received in the laboratory it has been decided that minimal dose of the quick lime needed for sludge processing should amount to 30% by weight.

Table 3. Composition of a product received on the laboratory scale with different dose of quick lime

Parameters	Doses of lime, %			
	10	25	30	35
Moisture, %	44.6	34.2	31.9	26.5
Total solids, %	55.4	65.8	68.1	73.5
Total solids, fixed %	76.2	88.5	92.6	95.8
Total solids, volatile %	23.8	11.5	7.4	4.2
Sulphur, mg S_{SO_4}/kg_{ts}	57.6	37.5	27.8	20.5
Calcium, mg Ca/kg_{ts}	169529	244266	257128	266977
Iron, mg Fe/kg_{ts}	8106	8030	7578	7097
Zinc, mg Zn/kg_{ts}	434.5	407.4	356.3	331.4
Vanadium, mg V/kg_{ts}	760.8	652.9	559.2	505.1
Nickel, mg Ni/kg_{ts}	194.4	181.0	146.5	137.4
Copper, mg Cu/kg_{ts}	74.0	72.4	59.1	55.7
Lead, mg Pb/kg_{ts}	167.0	151.5	151.3	141.5
Chromium, mg Cr/kg_{ts}	42.9	39.3	28.1	22.6
Cadmium, mg Cd/kg_{ts}	13.2	13.0	12.4	12.1
Oil and grease, %	18.6	14.0	6.6	5.4
Hydrocarbons, %	10.5	7.0	3.1	2.5

Characterization of a product received on the full-scale scale

A product was received in a technical installation whose scheme is presented at Figure 1. Every single part of this installation was bought ready, but the complete installation for converting the sludge into the product was designed by authors. The main element of it is reactor (no. 6), where the sludge undergoes rapid homogenization with quick lime, what secures equal conditions of solidification process in the whole mass of the sludge. The capacity of the installation was about 10 Mg/day. More than 200 Mg of the products were manufactured in the whole course of experiment.

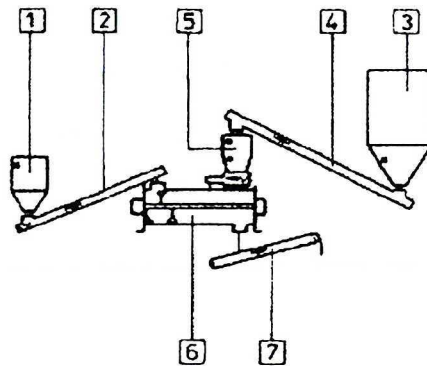

Fig. 1. Full – scale installation for processing of wastewater sludge with quick lime
 1 – sludge tank, 2 – feeding screw for sludge, 3 – lime silo, 4 – feeding screw for lime, 5 – weight feeder for lime (balance), 6 – reactor (mixer), 7 – conveyor of granulated product

Solidification of oil sludge with quick lime resulted in a solid, powder-like product. The product is not dusty, hydrophobic, and is easier to handle, transport and storage than wet sludge. Because of the significant amount of lime in the product including active compounds of lime (CaO and $\text{Ca}(\text{OH})_2$) and its powdered form, there are practical possibilities to use the product as a binder for soils improvement and stabilization [4, 5]. Taking into account a grain-size distribution, the content of a finest fraction (below 0.075 mm) is 82 to 92% of the product. According to the geotechnical classification [10] the product belongs to the class "fine".

Chemical characterization of the received products from the full-scale installation is presented in Table 4 (number of samples $n = 10$).

Table 4. Composition of a product from a technical installation

Parameters	Contents in the product
Moisture, %	25.0 – 37.8
Total solids, %	62.2 – 75.0
Total solids, fixed %	91.5 – 97.5
Total solids, volatile, %	2.5 – 8.5
Sulphur, mg S_{SO_4} /kg _{ts}	10 – 19
Calcium, mg Ca/kg _{ts}	293776 – 381906
Iron, mg Fe/kg _{ts}	7320 – 7957
Zinc, mg Zn/kg _{ts}	101.0 – 286.4
Vanadium, mg V/kg _{ts}	183.1 – 455.9
Nickel, mg Ni/kg _{ts}	101.2 – 175.3
Copper, mg Cu/kg _{ts}	32.6 – 52.7
Lead, mg Pb/kg _{ts}	67.5 – 87.9
Chromium, mg Cr/kg _{ts}	9.7 – 15.4
Cadmium, mg Cd/kg _{ts}	7.8 – 13.8
Oil and grease, %	2.4 – 5.3
Hydrocarbons, %	1.4 – 4.3

The following chemical properties, important for product use in road construction, were observed: 25–38% of water, about 30–40% calcium content in a dry matter, hydrocarbons concentration to 43 g/kg and several times lower concentration of heavy metals comparing to the sludge.

Leachability evaluation of pollutants

The use of solidified oil sludge in road construction relates to a danger of the release of components from the product due to contact with water. Taking this into account, investigations of pollutants leaching were conducted for the product obtained in a full-scale installation. The investigations were necessary to provide the guidelines and recommendations for the product utilization in road construction works.

To determine the fixation of the contaminants in a matrix of product physical and chemical analyses of water extracts for oil sludge and product were carried out (Tab. 5).

Table 5. Quantity of pollution leaching from the sewage sludge and from the technical product

Parameters	From sludge	From product	Concentration required for discharge *
pH	8.14–8.55	12.5–12.9	6.5–8.5
Conductivity, $\mu\text{S}/\text{cm}$	938–1680	5320–7420	not limited
COD _{Cr} , $\text{mg O}_2/\text{dm}^3$	695.8–1954.9	239–569	125.0
Chloride, $\text{mg Cl}/\text{dm}^3$	177.5–213.0	46–110	1000.0
Sulfate, $\text{mg SO}_4/\text{dm}^3$	50.0–117.0	n.w.	500.0
Calcium, $\text{mg Ca}/\text{dm}^3$	220–331	2065–6266	not limited
Iron, $\text{mg Fe}/\text{dm}^3$	3.7–7.3	0.1–0.3	10.0
Zinc, $\text{mg Zn}/\text{dm}^3$	1.0–1.5	0.1–0.2	2.0
Vanadium, $\text{mg V}/\text{dm}^3$	2.3–2.7	0.2–0.4	2.0
Nickel, $\text{mg Ni}/\text{dm}^3$	0.6–1.0	0.6–2.3	0.5
Copper, $\text{mg Cu}/\text{dm}^3$	0.1–0.3	0.2–0.6	0.5
Lead, $\text{mg Pb}/\text{dm}^3$	1.5–1.8	0.2–1.7	0.5
Chromium, $\text{mg Cr}/\text{dm}^3$	0.01–0.03	0–0.02	1.0
Cadmium, $\text{mg Cd}/\text{dm}^3$	0.08–0.13	0–0.09	0.4
Oil and grease, mg/dm^3	138–546	17–36	20
Hydrocarbons, mg/dm^3	59–196	10–29	15

* - Executive Order of the Minister of the Environment of November 29, 2002 (item 1799)

The water extracts from a product are characterized by a very high pH, considerably exceeding the highest permissible value for the sewage introduced to the water and the soil. Additionally, leaching most of other substances from a product has decreased, comparing to the sludge. However, extracts still contain too high concentrations of organic pollutants including hydrocarbons, which exceed permissible norm. Besides, copper content is on the top limit of admissible norm, nickel and lead concentrations in some analyzed extracts exceeded the highest values provided by the Order of the Minister of the Environment.

An analytical study of leaching of hazardous components has shown that the product can cause some harmful environmental impact links with alkalization of water environment as well as petroleum product and heavy metals contamination.

As a result of the above laboratory tests some technical solutions had to be developed to prevent contaminants spreading from the product in surrounding environment in order to make the product's use in road construction possible.

According to the laboratory test results, the product's use in road construction requires avoiding direct contact with the rain, surface water and groundwater. The use of the product to improve and stabilize only the base course of roads is recommended. Moreover, a concentration of the product in a place of using (stabilized layers) should be limited to 8% of the soil (by weight). Good mixing with the soil is recommended.

CONCLUSIONS

The oil sludge from the PKN Orlen wastewater treatment plant in Płock contains hazardous substances, and its storage brings about a real threat to the environment due to the leakage of elute to water and soil.

The solidification effects of oil sludge with quick lime and the environmental impact of solidified sludge for its use in road construction works were studied. The following results were obtained:

- It is possible to solidify with quick lime the oil sludge containing 60–75% of free water and under 20% petroleum products.
- A minimum amount of 30% quick lime is required in the mixture with wet oil sludge to obtain a powdered product.
- The mobility of the contaminants in the product is reduced in comparison with the sludge but some of the leachable contaminants still exceed limits imposed by environmental regulations.
- Technical solutions to the product's use in road constructions and earthworks to ground improvement and stabilization have to prevent the product from exposure to the rain, surface water and ground water contact.
- Product contribution in ground stabilization up to 8% should be applied to reduce the environmental impact of the product. Good mixing with the soil is recommended.
- One should expect that it is possible to create such conditions of utilization that environmental impact of solidified sludge is within limits determined by the national regulations. Further investigations will be made in that direction.

REFERENCES

- [1] Bartkiewicz B.: *Ścieki przemysłowe*, Oficyna Wydawnicza Politechniki Warszawskiej, Warszawa 2000.
- [2] Directive 75/442/EEC of 15 July 1975 on waste.
- [3] King T., A. Bruce: *Niszczanie substancji organicznych i stabilizacja metali*, Center of Hazardous Materials Research, USA, System Informatyczny Gospodarki Odpadami Przemysłowymi (SIGOP) – Instytut Gospodarki Odpadami w Katowicach.
- [4] Kraszewski C., J. Pachowski: *Osady porafineryjne z PKN Orlen S.A. w Płocku przetwarzane metodą ORTWED jako spoiwo do wzmacniania gruntów w budownictwie drogowym*, VI Konferencja Naukowo-Techniczna: Aktualne problemy naukowo-badawcze budownictwa, Olsztyn – Kortowo 2003.
- [5] Kraszewski C., J. Pachowski: *Możliwości ulepszenia i stabilizacji gruntów mineralnych i popiołów z węgla kamiennego produktem otrzymanywanym w wyniku zestalenia uwodnionych osadów porafineryjnych z PKN Orlen S.A. wapnem palonym*, IX Międzynarodowa Konferencja: Trwałe i bezpieczne nawierzchnie drogowe, Kielce, 2003.
- [6] Martin E., H. Schipper: *Best available techniques to reduce emissions from refineries*, CONCAWE Document No. 99/01, Brussels 1999.
- [7] Noskiewicz P.: *Próby utylizacji petrochemicznych osadów ściekowych w Płocku*, XV Sympozjum – AQUA'94, Problemy Ochrony i Kształtowania Środowiska Człowieka, Warszawa, Płock 21–22 maja 1994, str. 299–316.
- [8] Olaszczuk P., A. Lesiuk: *Unieszkodliwianie odpadów niebezpiecznych z zastosowaniem procesów obróbki fizyko-chemicznej. Cz. II. Zestalenie odpadów niebezpiecznych z wykorzystaniem cementu*, Ochrona powietrza i problemy odpadów, 36(4), 149–153 (2002).
- [9] Oudenhoven van.: *Oil refinery waste disposal methods, quantities and costs 1993 survey*, CONCAWE Report No. 1/95, Brussels, 1995.
- [10] PN-86/B-02480 Grunty budowlane. Określenia, symbole, podział i opis gruntów.

- [11] Rozporządzenie Ministra Ochrony Środowiska, Zasobów Naturalnych i Leśnictwa z dnia 27 września 2001 r. w sprawie katalogu odpadów, Dz. U. nr 112, poz. 1206.
- [12] Skalmowski K.: *Poradnik gospodarowania odpadami*, Dashöfer Verlag, Warszawa 1999.
- [13] Soundararajan R.: *An overview of present day immobilization technologies*, J. Hazard. Mater., 24, 199–212 (1990).
- [14] Stępnik S.: *Możliwości unieszkodliwiania przez zestalenie szlamistych odpadów niebezpiecznych*, Ochrona powietrza i problemy odpadów, 1, 59–63 (1997).
- [15] *Technologia zestalania osadów zaolejonych z myjni samochodowych i warsztatów naprawczych*, Technologic wykorzystania odpadów – Informator, Instytut Gospodarki Odpadami w Katowicach, Katowice 1993.
- [16] Ustawa o odpadach z dnia 27 kwietnia 2001 r., Dz. U. nr 62, poz. 628.
- [17] Wiles C.: *A review of solidification/stabilization technology*, J. Hazard. Mater., 14, 5–21 (1987).

Received: November 7, 2005; accepted: February 6, 2006.