



Co-published by
Institute of Fluid-Flow Machinery
Polish Academy of Sciences
Committee on Thermodynamics and Combustion
Polish Academy of Sciences

Copyright©2024 by the Authors under licence CC BY-NC-ND 4.0

<http://www.imp.gda.pl/archives-of-thermodynamics/>



Carbon dioxide capture in large-scale CCGT power plant from flue gases obtained from various fuel mixtures

Navaneethan Subramanian*, Paweł Madejski

AGH University of Science and Technology, Faculty of Mechanical Engineering and Robotics, al. Mickiewicza 30, 30-059 Kraków, Poland

*Corresponding author email: subraman@agh.edu.pl

Received: 31.01.2024; revised: 22.07.2024; accepted: 08.10.2024

Abstract

In this study, the thermodynamic analysis of a combined cycle gas turbine integrated with post-combustion carbon capture and storage using the solvent method is performed. The syngas obtained from the gasification of sewage sludge is mixed with methane and nitrogen-rich natural gas fuels at different proportions, used in the gas turbine, and the properties of fuel and flue gases are analyzed. The flue gas obtained from the fuel mixture is passed through the post-combustion carbon capture and storage at various load conditions to assess the heat and electricity required for the carbon capture process. The solvent used for the carbon capture from flue gases enables CO₂ capture with the high efficiency of 90%. With the calculated results, the load conditions of flue gas using fuel mixtures are identified, which reduces the heat and power demand of post-combustion carbon capture and storage and provides the possibility to achieve neutral emission. The impact of selected operating conditions of post-combustion carbon capture and storage on the CO₂ emission reduction process and on the power plant performances is investigated. Considering the factors of electricity generation, energy efficiency, heat supply to the consumers, operating load of post-combustion carbon capture and storage and CO₂ emission, the 50% mixture of syngas with both fuels performs better. Also, the use of a mixture of 2-amino-2methyl-1-propanol and piperazine with reboiler duty 3.7 MJ/kgCO₂ in post-combustion carbon capture and storage slightly enhanced the performance of the power plant compared to the use of monoethanolamine with reboiler duty 3.8 MJ/kgCO₂.

Keywords: Thermodynamic modelling; Combined Cycle Gas Turbine; Post-combustion carbon capture and storage; CO₂ capture; Negative emission

Vol. 45(2024), No. 4, 81–89; doi: 10.24425/ather.2024.151999

Cite this manuscript as: Subramanian, N., & Madejski, P. (2024), Carbon dioxide capture in large-scale CCGT power plant from flue gases obtained from various fuel mixtures. *Archives of Thermodynamics*, 45(4), 81–89.

1. Introduction

A recent report by the International Energy Agency (IEA) in 2023 states that global energy-related emissions have reached 36.8 billion tons in the year 2022, which made the limiting global average temperature to 1.5°C by 2100 impossible. The expeditious actions by the conference of the parties (COP) will make it possible to limit the temperature to 1.7°C. Among the pathways suggested for limiting the increasing temperature in

the energy sector, the carbon capture and storage (CCS), carbon capture utilization and carbon dioxide removal are among the many methods [1]. According to the Intergovernmental Panel on Climate Change (IPCC), as an effort to limit the global average temperature to below 2°C and to achieve net zero emission or 'negative emissions', the Bioenergy with Carbon Capture and Storage (BECCS) appears to be a feasible option [2], which can reach a potential of capturing 50 Mt CO₂/year by 2030 [3]. BECCS results in utilization of byproducts obtained from the

Nomenclature

Abbreviations and Acronyms

AEEA	– aminoethyl ethanolamine
AMP	– 2-amino-2methyl-1-propanol
BAE	– 2-(butylamino)ethanol
BECCS	– bioenergy with carbon capture and storage
CCGT	– combined cycle gas turbine
CCS	– carbon capture and storage
COP	– conference of parties
DEA	– diethanolamine
DETA	– diethylenetriamine
DHN	– district heating network

EAE	– 2-(ethylamino)ethanol
EGBE	– 2-butoxyethanol
HP	– high pressure
HRSG	– heat recovery steam generator
IEA	– International Energy Agency
IPCC	– intergovernmental panel on climate change
LP	– low pressure
MAE	– 2-(methylamino)ethanol
MDEA	– methyl diethanolamine
MEA	– monoethanolamine
PCCS	– post-combustion carbon capture and storage
PZ	– piperazine

thermochemical conversion process and integration with carbon capture technology, which helps not only to fight the climate change crisis but also to satisfy the energy demand [4].

The use of natural gas in combined cycle gas turbines (CCGT) integrated with post-combustion carbon capture (PCCS) provides low carbon emission and the possibility of achieving higher efficiency of CO₂ capture at a lower operational cost. During the steady state operation, CCGT with PCCS can provide a gross efficiency of 58% [5]. The cost saving of CCGT integrated with PCCS depends upon the effective operation of the power plant. When the electricity price is higher, the CCGT operation focuses on power generation and reduces the CO₂ capture process, thus producing more power output by reducing the energy penalty of CCS. When the carbon price is higher, the focus will be changed to the carbon capture process [6].

Post-combustion carbon capture works on low CO₂ concentrations and has minimised pressure loss when operated using solvents. Monoethanolamine (MEA), diethanolamine (DEA), methyl diethanolamine (MDEA), aminoethyl ethanolamine (AEEA), diethylenetriamine (DETA) are the most commonly used solvents in PCCS [7]. The PCCS process using chemical absorption solvents has a high carbon capture efficiency of 90% – 99% [8]. Despite amine loss and corrosion of utensils during the CO₂ capture process, MEA is the most widely used solvent due to its operation under partial pressure, capture rate and chemical kinetics [9]. The steam from the steam cycle of the power plant is used for the regeneration of the CO₂ capture process when operating PCCS is integrated with a power plant. Up to 10% of efficiency is reduced during the extraction of steam in the power plant due to the energy penalty, which can be minimized by introducing supplementary equipment such as a supplementary steam turbine [10]. Wu et al. [11] state that the introduction of solar energy for the PCCS regeneration process has improved the power generation in the steam cycle, which reduced the energy penalty to 6.93%.

The use of a single amine in PCCS has the drawback of consuming higher energy for regeneration and a lower absorption rate. Nowadays the use of blended solvents is gaining more attention because of the higher CO₂ capture rate and lower energy required for regeneration [12]. A simulation comparison by Ding et al. [13] shows that the blending of piperazine (PZ) with MEA and MDEA shows better performance by reducing regen-

eration energy and making the process more cost-effective compared to MEA and blended MEA-MDEA amines. Ping et al. [14] experimental study of nonaqueous secondary alkanolamines 2-(methylamino) ethanol (MAE), 2-(butylamino) ethanol (BAE) and 2-(ethylamino) ethanol (EAE) with 2-butoxyethanol (EGBE) used for the CO₂ capture process shows the blend of EGBE with BAE has a lower regeneration energy of 1.73 MJ/kgCO₂ compared to MEA which is 3.8 MJ/kgCO₂. The experimental study of blend solvents 2-amino-2methyl-1-propanol (AMP)-PZ-MEA with MEA shows that the blend of 6M–7M AMP-PZ-MEA solvents has 1.5–2.5 times higher mass transfer coefficient and better CO₂ capture rate than 5M MEA [15].

Due to the volatility of amine, the emission of amine with ammonia and other compounds occurs during oxidative degradation. This depends upon various factors such as operating conditions and the composition of flue gases, which can be reduced by cooling the treated flue gas at the outlet of the absorber, which is done by adding a water wash column [16].

Mathematical modelling of complex energy systems is a helpful tool in the analysis of conventional systems [17,18], those based on renewable energy sources [19], or hybrid energy systems [20]. Tools for the simulation of thermodynamics processes developed in recent years are increasingly popular, e.g. Aspen Plus, Aspen Hysys, GateCycle, IpsePRO or Ebsilon Professional are used in the presented case [21,22].

The novelty of the study is that it identifies the CO₂-neutral fuel mixture and shows simulation results of the performance of CCGT when integrated with PCCS. CCGT is operated using the fuels methane and nitrogen-rich natural gas mixed with syngas obtained from gasification of sewage sludge at different proportions of 25%, 50% and 75%. The flue gas produced from CCGT is passed at different load conditions from 50% to 100% for CO₂ removal to PCCS using the solvent method. Two different aqueous solvents 30wt% MEA and a blend of 16wt% AMP – 14wt% PZ are used in PCCS. The extraction of steam from CCGT for amine regeneration has an impact on the power plant performance. Based on the power generation, DHN heat supply, emission parameters and the regeneration energy of solvents in PCCS, the CO₂-neutral fuels are identified.

2. Model and simulation description

The thermodynamic model of Ebsilon [23] for flows of pure water/steam and data of IPAWS-IF97 [24] were used. The Red-

lich–Kwong–Soave real gas formulation [25] and NIST [26] data for calculating MEA mixture properties were adopted. The equations of state, mass and energy balances were resolved iteratively, with a convergence criterion set to 10^{-9} . This referred to the relative deviation between the second-last and the last iteration step for mass flow, pressure and enthalpy.

A model of CCGT operated with two Siemens SGT-800 gas turbines with a maximum power of 50.5 MW per turbine and a steam turbine with a maximum power of 65 MW is developed. The outlet gas from the gas turbine at 553°C is passed through the heat recovery steam generators (HRSGs) with high pressure (HP) and low pressure (LP) steam levels to produce steam for the steam turbine. An economizer is included at the last stage of HRSG for a district heating network (DHN) along with a heat exchanger, in which steam from the steam turbine is used as a hot stream to supply heat to the water. When using different fuels in the developed model of CCGT, the gas turbines increase the fuel mass flow to operate at full efficiency of 38.1%, which also depends upon the calorific value of the fuel. Gas fuels such as methane and N_2 -rich natural gas are used in gas turbines. To measure the possibility of achieving a ‘negative CO_2 emission’, syngas is mixed with the fuel at different proportions as 25%, 50% and 75%. When operating CCGT with PCCS, CCGT is always kept in full load condition and the flue gas to PCCS is directed with various load conditions between 50% and 100%. When supplying steam to the DHN heat exchanger and PCCS for amine regeneration, the power generation in the steam cycle varies with changing the behaviour of CCGT.

PCCS uses an aqueous solution of 30wt% MEA and 16wt%+14wt% of AMP-PZ solvents and has a CO_2 capture efficiency of 90% and rich CO_2 loading of 0.5, 0.62 and 0.86 mol-

$\text{CO}_2/\text{mol-amine}$, respectively. The absorber operates at 40°C , 1 bar and the stripper operates at 120°C , 2 bar, respectively. The model incorporates mass and energy balance equations to ensure accurate simulation of the entire process. These balances account for the flow rates, temperatures and pressures of all streams entering and exiting each component. The reaction mechanism between the amines (MEA, AMP-PZ) and CO_2 in flue gas is manually described within the absorber component, as CO_2 is selectively separated from the flue gas stream based on the capture efficiency. CO_2 is then mixed with the amine solution, resulting in the formation of rich amine flow at the bottom outlet of the absorber. A water wash system is added to the top of the absorber to minimize solvent emission by cooling the low CO_2 flue gas stream exiting the absorber, thereby condensing and capturing any solvent vapours before they are released into the atmosphere. The rich amine from the absorber is pre-heated before it enters the stripper. The rich amine solution is further heated in a reboiler using steam from CCGT. This heating process facilitates the separation of CO_2 from amine. When the amine flows back inside the stripper, CO_2 gets separated exiting the top of the stripper. The reaction mechanism in the stripper is described similarly to the absorber component, where CO_2 is separated using the separator component of the model according to the lean amine loading from the amine stream from the reboiler to the stripper after heating. The separated CO_2 is cooled and compressed up to 110 bar at the CO_2 compression system.

Based on the Gorzów CCGT power plant in Poland [27] and the theoretical analysis of PCCS using the solvent method for different flue gases, a model of CCGT integrated with PCCS as in Fig. 1 is developed.

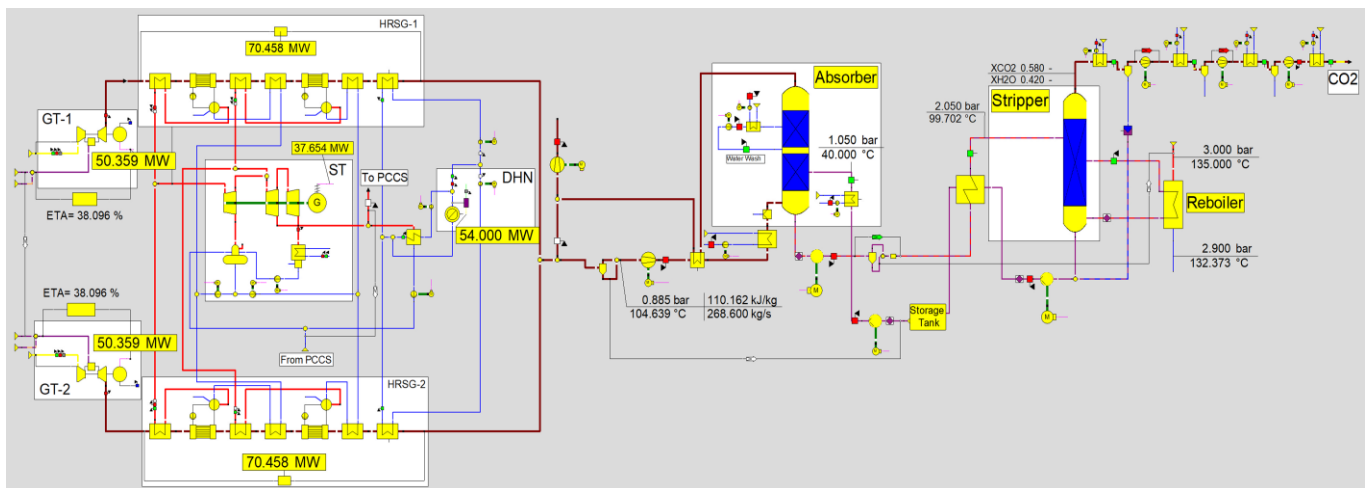

Fig. 1. Model of CCGT integrated with PCCS developed using Epsilon® Professional 16.

Based on the rich CO_2 loading calculation and depending upon the CO_2 at the PCCS inlet, the required amount of lean solvent is given as input to the absorber model [28]. The model increases or decreases the flow of amine required for the capture to the absorber, considering the flow of CO_2 in the flue gas. Due to the absence of gas-to-liquid phase mass transfer and chemical reaction in the simulation, the internal reactions are manually described in the model using the study.

3. Results and discussion

3.1. Fuel composition and emission

The composition of the fuels and mixture of fuels used in the gas turbine for combustion such as methane with syngas and N_2 -rich natural gas with syngas at different proportions changes with an increase in the proportion of syngas along with a change in the lower heating value (LHV) of the fuels. LHV of methane,

N₂-rich fuel and syngas are 50.5 MJ/kg, 18.63 MJ/kg and 17.08 MJ/kg, respectively. The presence of CO₂ content in syngas increases the CO₂ content in the other fuels when mixed. When mixing syngas with the other fuels, the lower heating value changes due to the increasing syngas content in the fuel, and the CO₂ content increases. The fuels and the mixture of fuels are given as an input to the gas turbine at 30 bar and 25°C. The fuels and mixture of fuels are used in the gas turbines of CCGT and CO₂ emissions are analyzed as in Fig. 2. Due to the CO₂ content in fuel, the combustion of the fuels results in an increase in CO₂ emission in flue gas with an increased syngas proportion. After various stages of HRSG, the flue gas at 0.885 bar and 104.6 °C is passed to PCCS for CO₂ removal process.

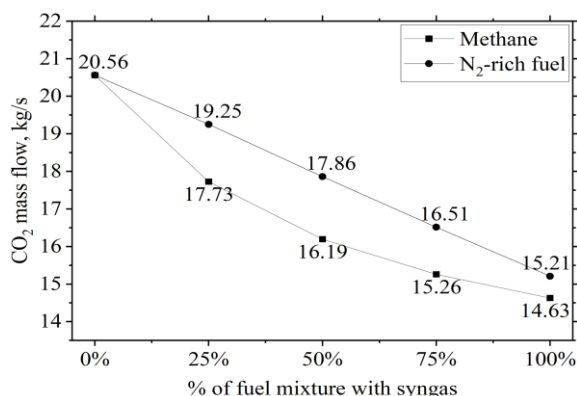

Fig. 2. CO₂ emission from fuels mixed with syngas at different proportions.

When the flue gas passes through PCCS at different load conditions, the flue gas diverted from PCCS is passed directly into the atmosphere. When passing flue gases to PCCS at different proportions from 50% to 100%, the CO₂ content at the inlet of PCCS gets reduced as in Fig. 3.

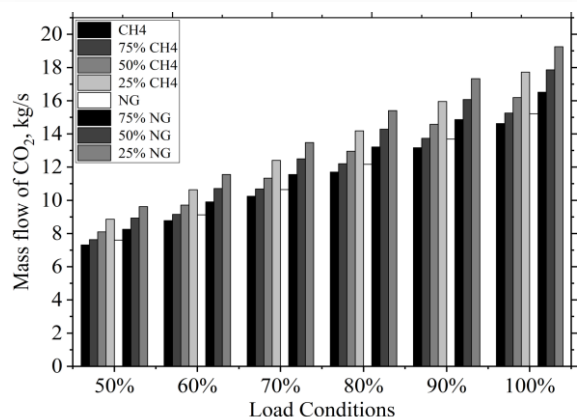

Fig. 3. CO₂ emission from different fuels at the inlet of PCCS increasing with the increase in flue gas load condition.

3.2. Performance of CCGT without PCCS

The change in content of the fuel when mixed with syngas does not have any adverse effects on the performance of CCGT without PCCS. This is because the gas turbine adjusts the mass flow

rate of the fuel according to its LHV, ensuring consistent performance. With the maximum load of DHN heat supply of 54 MW, gas cycle power generation is 100.72 MW, and steam cycle power generation 37.65 MW. The performance metrics of CCGT without PCCS as detailed in Table 1 remain unchanged for using fuels and a mixture of fuels in the CCGT gas turbine.

Table 1. Performance of CCGT without PCCS operation.

Parameters	Unit	Value
Gross energy (power + heat)	MW	192.37
Net energy (power + heat)	MW	138.37
Net power	MW	128.43
Plant power consumption	MW	9.94
Gross energy efficiency	%	72.84
Net energy efficiency	%	52.4
Net power efficiency	%	48.63

Even after accounting for the power consumption of 9.94 MW by CCGT, the net power produced 128.43 MW is delivered to the grid. This demonstrates that the mixture of syngas does not impair the overall efficiency and effectiveness of the CCGT in generating electricity and supplying heat to DHN. The adaptability of the gas turbine to different fuel compositions ensures steady performance and reliable power output to the grid.

3.3. Performance of CCGT with PCCS

When operating CCGT integrated with PCCS using MEA, the Gross power production of the CCGT is maintained between 129 MW to 131 MW by adjusting the DHN heat supply. For the comparison purpose, during the PCCS operation with AMP-PZ amine, the same DHN heat supply given for PCCS using MEA is used to measure the Gross power production as shown in Fig. 4 and Fig. 5 for MEA and AMP-PZ solvents, respectively. Initially for flue gas to PCCS at full load condition, the heat supplied to DHN (Fig. 6) according to the availability of steam in the steam cycle. The reduced flue gas load conditions to PCCS reduce the steam requirement for amine regeneration, making more steam available for steam cycle power generation and increasing the DHN heat supply without much possible change in gross power. Considering the nominal load of DHN heat supply as 54 MW and depending upon the load condition and fuel used in CCGT, Fig. 7 shows the % of nominal power at different flue gas load conditions of PCCS depending on fuel mixture as net energy is maintained between 129 MW to 132 MW. Followed by the various operating procedures of CCGT integrated with PCCS operations, the change in gross energy efficiency of the power plant is noticed in Fig. 8. Since the net energy production is maintained between 130 MW to 132 MW by adjusting heat to DHN, the net energy efficiency in all the PCCS load conditions has very slight differences. Figure 9 shows the total power consumed by the equipment in CCGT and PCCS including the pumps, blowers, and CO₂ compression system.

Since the carbon capture efficiency of the solvents used in the PCCS is the same, PCCS captures 90% of CO₂ from flue gases. Considering the highest CO₂ capture from syngas of 18.62 kg/s, the nominal capture rate in percentage is given in Fig. 10. Due

to the change in the amine stream and gas stream with respect to the CO₂ content in the flue gas, the power consumption by PCCS varies. With the varying load conditions, the PCCS consumes 5.5% to 11.4% of the power from CCGT for its use. The lower the flue gas load operated, the lower the power consumed by PCCS.

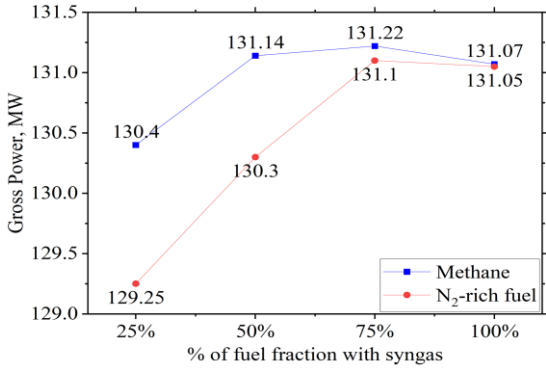

Fig. 4. Gross power generation of CCGT using fuel and fuel mixture with syngas and treating flue gas in PCCS at full load conditions using MEA.

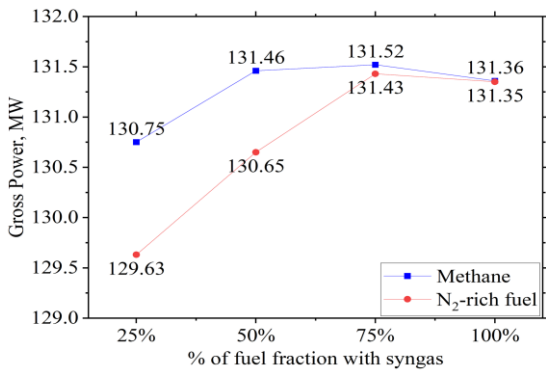

Fig. 5. Gross power generation of CCGT using fuel and fuel mixture with syngas and treating flue gas in PCCS at full load conditions using AMP-PZ.

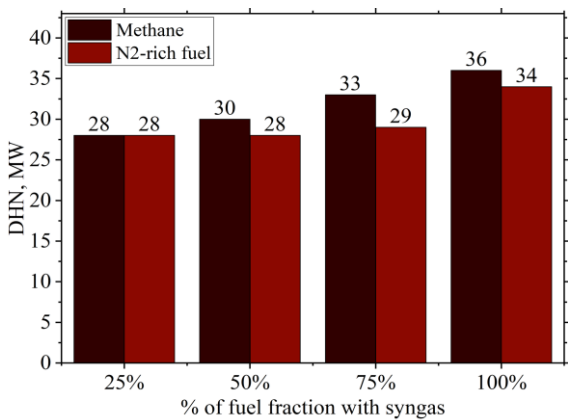

Fig. 6. Heat supplied to district heat network at full load condition of PCCS depending on fuel mixture as the net energy is maintained between 129 MW to 132 MW.

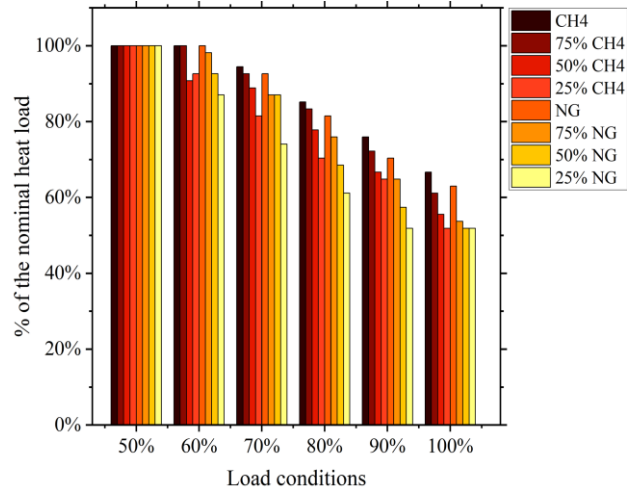

Fig. 7. Percentage of nominal heat load variation in heat supplied to district heat network at different flue gas load conditions of PCCS.

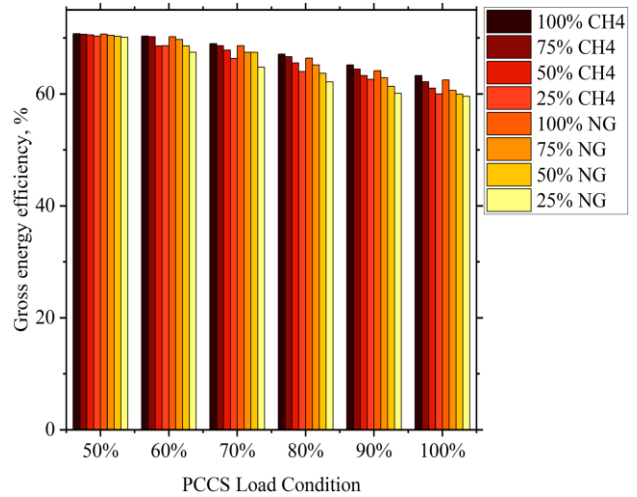

Fig. 8. Gross energy efficiency of CCGT using fuel mixture with syngas and treating flue gas in PCCS at variable load conditions.

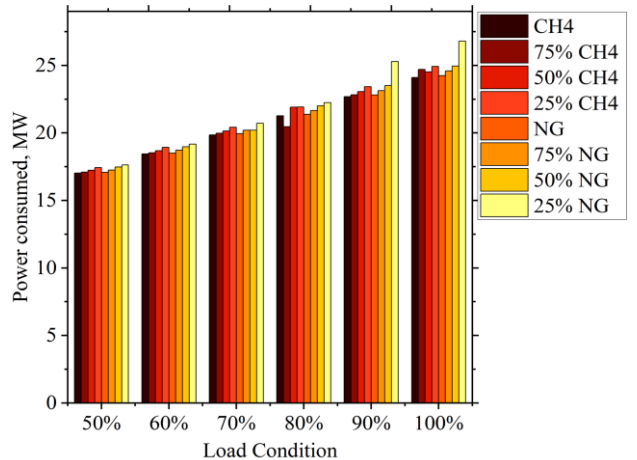

Fig. 9. Total power consumption of CCGT using different fuels and mixture of fuels with PCCS operated under different load conditions.

After the CO₂ capture process, only 10% of CO₂ is emitted into the atmosphere from PCCS operated at full load condition. When PCCS is operated at different load conditions, CO₂ in flue gas diverted from PCCS is directly passed into the atmosphere. Hence, reducing load conditions in PCCS increases the CO₂ emission into the atmosphere. The CO₂ emission is estimated by the procedure that when biogas produced from biomass is used as fuel and CCS is performed, the emission is considered as ‘zero-emission’.

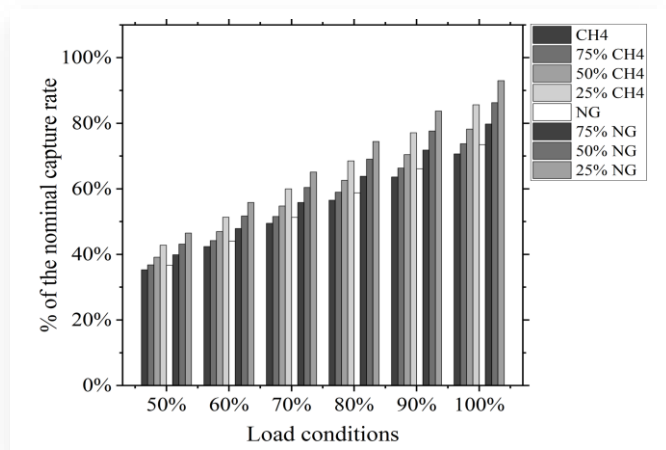

Fig. 10. Percentage of nominal CO₂ capture rate in PCCS at different load conditions from flue gases produced by different fuels.

When a syngas mixture with other fuels is used for combustion, the CO₂ emitted is estimated by the captured CO₂ from the share of syngas and the CO₂ emitted into the atmosphere according to the load changes in PCCS. When the flue gas load to PCCS is reduced, more amount of flue gas diverted from PCCS passes to the atmosphere and less amount of CO₂ from the share of syngas enters PCCS, making it less possible to achieve negative emission as in Fig. 11. The range of CO₂ emission after PCCS varies from 8.36 kg/s to -4.28 kg/s depending upon the fuel mixture and PCCS flue gas load conditions.

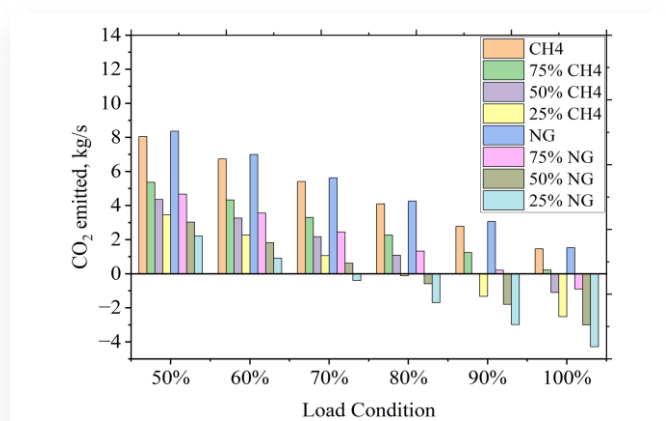

Fig. 11. CO₂ emitted into the atmosphere after flue gas from different fuel mixtures treated in PCCS at different load condition.

3.4. Analysis of PCCS using different solvents

The model regulates the flow of amines based on the proportion of CO₂ entering the PCCS at different load conditions and from

flue gases produced by various fuels or mixtures of fuels, as illustrated in Fig. 12 and Fig. 13 for PCCS using MEA and a blend of AMP-PZ, respectively. The requirement of MEA and AMP-PZ changes according to the CO₂ concentration in the flue gas and the rich loading of the amine used. Initially, the mass flow rate of lean amine necessary for capturing 14.63 kg/s of CO₂ produced by burning methane in a combined cycle gas turbine (CCGT) is calculated to be 136.68 kg/s for MEA and 136.73 kg/s for AMP-PZ.

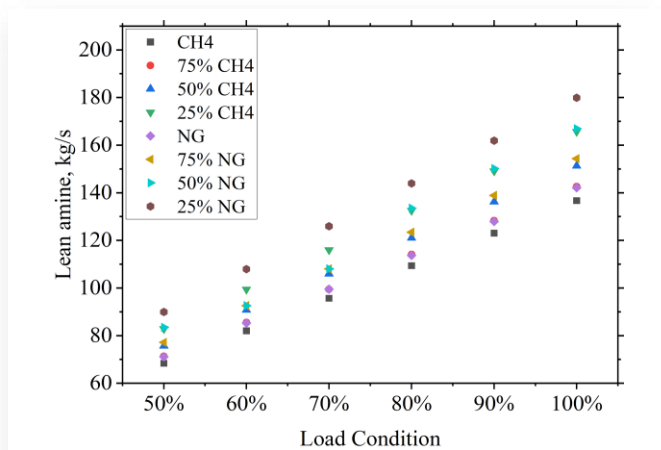

Fig. 12. Mass flow of lean MEA supplied to the absorber with PCCS operated under different load conditions to treat flue gases from different fuels and fuel mixtures.

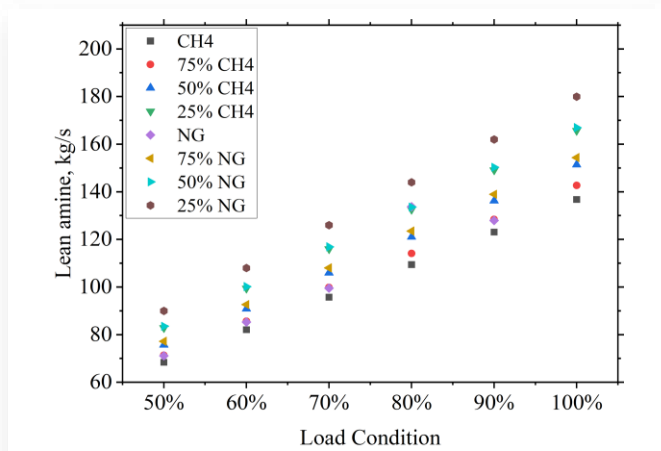

Fig. 13. Mass flow of lean AMP-PZ supplied to the absorber when PCCS operated under different load conditions to treat flue gases from different fuels and fuel mixtures.

The steam needed for the reboiler in PCCS is extracted from the LP turbine of CCGT at a temperature of 135°C and a pressure of 3 bar. Considering the reboiler duty of MEA and AMP-PZ, which is 3.8 MJ/kg-CO₂ and 3.7 MJ/kg-CO₂, respectively, the mass flow rate of steam required for processing 13.26 kg/s of captured CO₂ in rich amines is calculated to be 23.19 kg/s for MEA and 22.58 kg/s for AMP-PZ. The model adjusts these initial calculated values based on the CO₂ content in the rich amine. As the CO₂ content varies, the mass flow rate of steam extracted from CCGT for the reboiler is adjusted, as shown in Fig. 14 and Fig. 15 for PCCS utilizing MEA and AMP-PZ solvents.

The steam consumption by the reboiler for treating flue gases from a 25% N₂-rich natural gas and 75% syngas fuel mixture is higher compared to that of other fuels. The steam consumption varies from 31.38 kg/s to 15.69 kg/s for using MEA and 30.56 kg/s to 15.28 kg/s for AMP-PZ in operating PCCS at different load conditions. The minimum steam consumption for the reboiler among the fuels used is for methane, and varies from 23.85 kg/s to 11.92 kg/s for MEA and 23.22 kg/s to 11.61 kg/s for AMP-PZ depending upon the load conditions.

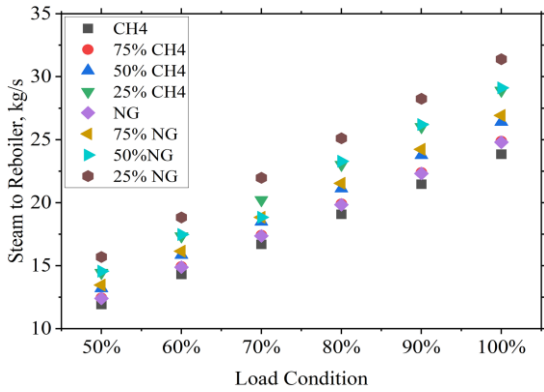

Fig. 14. Steam consumption by the reboiler of PCCS using MEA solvent for flue gases from different fuels and mixture of fuels.

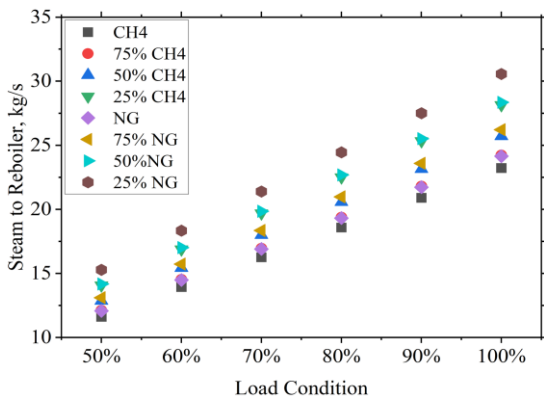

Fig. 15. Steam consumption by the reboiler of PCCS using AMP-PZ solvent for flue gases from different fuels and mixture of fuels.

3.5. Indicators of CO₂ emission level assessment

With the data obtained from CCGT and PCCS using different fuels, mixtures of fuels and different solvents, the CO₂ emission level assessment indicators are calculated using formulas given in [29]. Despite achieving a solvent CO₂ capture efficiency of 90%, due to the operational condition of PCCS, the CO₂ capture ratio fluctuates with the operational conditions of PCCS. Specifically, this ratio varies between 0.45 to 0.9, corresponding to 50% and 100% of PCCS load, respectively. Depending upon the load conditions, the capture ratio varies as the CO₂ capture is different from the CO₂ generated when changing the load conditions. The use of MEA and AMP-PZ in PCCS showed only minor differences in their impact on CCGT. Consequently, these differences did not significantly affect the specific emission and relative emissivity of CO₂.

Figures 16 and 17 illustrate the specific emission of CO₂ measured in g CO₂/kWh, for a methane mixture with syngas and N₂-rich fuel mixture with syngas, respectively. The relative emissivity of CO₂ in g/kWh is measured with the heat input from the fuel to CCGT of 264 088.22 kW as in Figs. 18 and 19. The heat input by the fuel is the same for all the fuels and fuel mixtures used in CCGT.

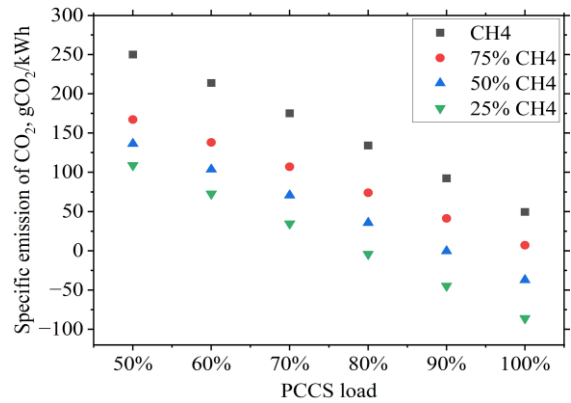

Fig. 16. Specific emission of CO₂ in g CO₂/kWh measured varying with PCCS load condition for the use of methane and its mixture with syngas in CCGT.

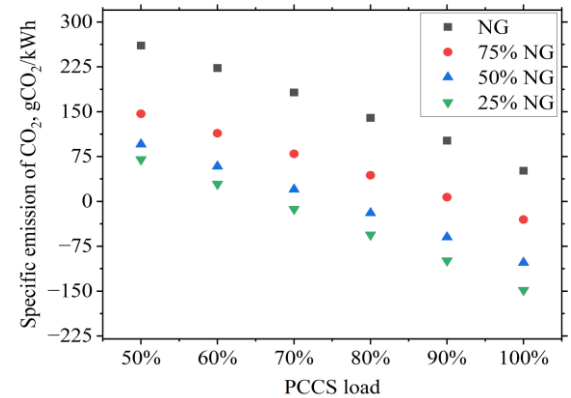

Fig. 17. Specific emission of CO₂ in g CO₂/kWh measured varying with PCCS load condition for the use of N₂-rich fuel and its mixture with syngas in CCGT.

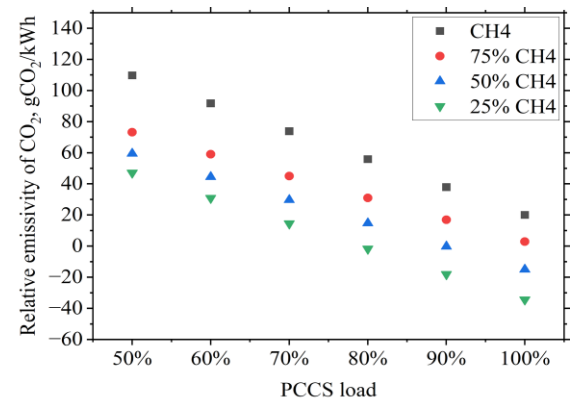

Fig. 18. Relative emissivity of CO₂ in g CO₂/kWh measured varying with PCCS load condition for the use of methane and its mixture with syngas in CCGT.

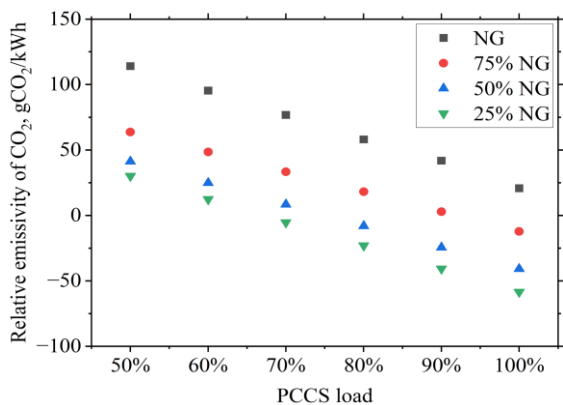

Fig. 19. Relative emissivity of CO₂ in g CO₂/kWh measured varying with PCCS load condition for the use of N₂-rich fuel and its mixture with syngas in CCGT.

When the PCCS process is not integrated into CCGT, the specific emission and relative emissivity measured from the power generation and CO₂ emission for various fuels are observed to be higher than the emission caused by CCGT as in Figs. 20 and 21 for the methane and N₂-rich fuel mixture with syngas, respectively.

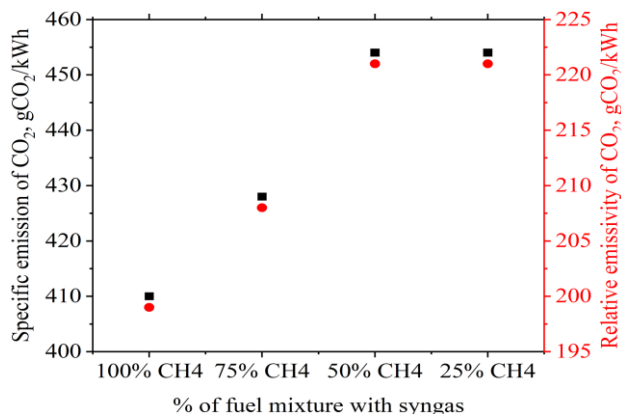

Fig. 20. Specific emission and relative emissivity of CO₂ in g CO₂/kWh measured for the use of methane and its mixture with syngas in CCGT without PCCS.

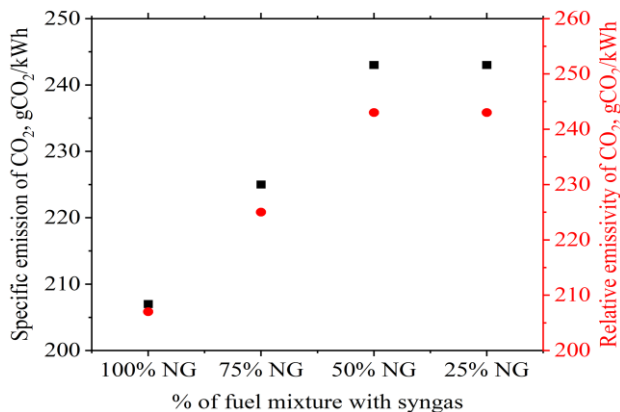

Fig. 21. Specific emission and relative emissivity of CO₂ in g CO₂/kWh measured for the use of N₂-rich fuel and its mixture with syngas in CCGT without PCCS.

4. Conclusions

The behaviour of CCGT integrated with PCCS hugely depends upon the type of fuel used in the gas turbine and the solvent used in PCCS. Since the steam required for the solvent regeneration is taken from the steam cycle of the power plant, it affects the overall efficiency and power generation. The modelling and simulation results obtained help to understand various thermodynamic properties of CCGT as well as PCCS. From the data, it is observed that when integrating CCGT with PCCS, the PCCS consumes 5.5% to 10.5% of power from the power plant for its use depending upon the load conditions and steam used for solvent regeneration. Considering the heat and power generation, and thermal efficiency of the power plant, the syngas mixture with both fuels at 50% helps achieve the possibility of zero or negative CO₂ emission without much disturbance in the heat and power generation process. Also, the load conditions of flue gas from a 50% syngas mixture with both fuels can be adjusted from 80% to 100% to PCCS to maintain a close-to-zero emission.

The increase of syngas in the mixture with methane and N₂-rich fuel increases the possibility of achieving ‘negative emission’ but on the other hand, the heat and power generation are reduced in the power plant, also it requires a huge resource of sewage sludge for the gasification process.

The use of AMP-PZ has very slight differences when compared to MEA in power consumption by PCCS, requirement of lean amine and heat supply to the reboiler. As referred to in [13], increasing the proportion of PZ in the solvent mixture can lower the regeneration rate, which will have a huge impact on the heat and power generation process of the power plant.

Acknowledgements

The research leading to these results has received funding from the Norway Grants 2014-2021 via the National Centre for Research and Development. Work has been prepared within the frame of the project: “Negative CO₂ emission gas power plant” – NOR/POLNORCCS/NEGATIVE-CO2-PP/0009/2019-00 co-financed by the programme “Applied research” under the Norwegian Financial Mechanisms 2014-2021 POLNOR CCS 2019 – “Development of CO₂ capture solutions integrated in power and industry processes”.

References

- [1] IEA (2023), Credible pathways to 1.5°C, *IEA, Paris*, License: CC BY 4.0. <https://www.iea.org/reports/credible-pathways-to-150c>. [accessed 17 Jan. 2024].
- [2] de Coninck, H., Revi, A., Babiker, M., Bertoldi, P., Buckeridge, M., Cartwright, A., Dong, W., Ford, J., Fuss, S., Hourcade, J.C., Ley, D., Mechler, R., Newman, P., Revokatova, A., Schultz, S., Steg, L., & Sugiyam, T. (2018). Strengthening and Implementing the Global Response. In *Global Warming of 1.5°C*. (pp. 313–444). Cambridge University Press. Cambridge USA doi: 10.1017/9781009157940.006
- [3] IEA (2022), Bioenergy with Carbon Capture and Storage, *IEA, Paris*. <https://www.iea.org/reports/bio-energy-with-carbon-capture-and-storage> [accessed 17 Jan. 2024].
- [4] Shahbaz, M., AlNouss, A., Ghiat, I., McKay, G., Mackey, H., Elkhalfifa, S., & Al-Ansari, T. (2021). A comprehensive review

- of biomass based thermochemical conversion technologies integrated with CO₂ capture and utilisation within BECCS networks. *Resources, Conservation and Recycling*, 173. doi: 10.1016/j.resconrec.2021.105734
- [5] Bui, M., Sunny, N., & Mac Dowell, N. (2023). The prospects of flexible natural gas-fired CCGT within a green taxonomy. *iScience*, 26. doi: 10.1016/j.isci.2023.107382
- [6] Chyong, C.K., Reiner, D., M., Ly, R., & Fajardy, M. (2023). Economic modelling of flexible carbon capture and storage in a decarbonised electricity system. *Renewable and Sustainable Energy Reviews*, 188. doi: 10.1016/j.rser.2023.113864
- [7] Kim, S., Ko, Y., Lee, G.J., Lee, J.W., Xu, R., Ahn, H., & Kang, Y.T. (2022). Sustainable energy harvesting from post-combustion CO₂ capture using amine-functionalized solvents. *Energy*, 267. doi:10.1016/j.energy.2022.126532
- [8] Liu, F., Qi, Z., Fang, M., & Ding, H. (2023). Pilot test of water-lean solvent of 2-(ethylamino) ethanol, 1-methyl-2-pyrrolidinone, and water for post-combustion CO₂ capture. *Chemical Engineering Journal*, 459. doi: 10.1016/j.cej.2023.141634
- [9] Kindra, V.O., Milukov, I.A., Shevchenko, I.V., Shabalova, S.I., & Kovalev, D.S. (2023). Thermodynamic analysis of cycle arrangements of the coal-fired thermal power plants with carbon capture. *Archives of Thermodynamics*, 42(4), 103–121. doi: 10.24425/ather.2021.139653
- [10] Xu, C., Li, X., Liu, X., & Li, J. (2020). An integrated decarbonization supercritical coal-fired power plant incorporating a supplementary steam turbine, process heat recovery and a modified boiler structure. *Applied Thermal Engineering*, 178. doi: 10.1016/j.applthermaleng.2020.115532
- [11] Wu, Y., Dai, Y., Xie, W., Chen, H., & Zhu, Y. (2022). Performance analysis for post-combustion CO₂ capture in coal-fired power plants by integration with solar energy. *Energy*, 261. doi: 10.1016/j.energy.2022.125239
- [12] Xiang, J., Wei, D., Mao, W., Liu, T., Luo, Q., Huang, Y., Liang Z., & Luo, X. (2024). Comprehensive kinetic study of carbon dioxide absorption in blended tertiary/secondary amine solutions: Experiments and simulations. *Separation and Purification Technology*, 330(part B). doi: 10.1016/j.seppur.2023.125310
- [13] Ding, X., Chen, H., Li, J., & Zhou, T. (2023). Comparative techno-economic analysis of CO₂ capture processes using blended amines. *Carbon Capture Science and Technology*, 9. doi: 10.1016/j.ccst.2023.100136
- [14] Ping, T., Dong, Y., & Shen, S. (2020). Energy-Efficient CO₂ Capture Using Nonaqueous Absorbents of Secondary Alkanolamines with a 2-Butoxyethanol Cosolvent. *ACS Sustainable Chemistry and Engineering*, 8(49), 18071–18082. doi:10.1021/acssuschemeng.0c06345
- [15] Nakrak, S., Chalermisinsuwan, B., Tontiwachwuthikul, P., Gao, H., Liangz, Z., & Sema, T. (2023). Comparative mass transfer performance of CO₂ absorption using highly-concentrated AMP-PZ-MEA ternary amines solvent. *Energy Reports*, 9, 1–7. doi: 10.1016/j.egyr.2023.05.219
- [16] Spietz, T., Dobras, S., Chwoła, T., Wilk, A., Krótki, A., & Więclaw-Solny, L. (2020). Experimental results of amine emission from the CO₂ capture process using 2-amino-2-methyl-1-propanol (AMP) with piperazine (PZ). *International Journal of Greenhouse Gas Control*, 102. doi: 10.1016/j.ijggc.2020.103155
- [17] Tramošljika, B., Blecich, P., Bonefačić, I., & Glažar, V. (2021). Advanced Ultra-Supercritical Coal-Fired Power Plant with Post-Combustion Carbon Capture: Analysis of Electricity Penalty and CO₂ Emission Reduction. *Sustainability*, 13. doi: 10.3390/su13020801
- [18] Madejski, P., & Żymelka, P. (2020). Calculation methods of steam boiler operation factors under varying operating conditions with the use of computational thermodynamic modeling. *Energy*, 197. doi: 10.1016/j.energy.2020.117221
- [19] Başaran, T., Çetin, B., & Özdemir, M.R. (2022). Thermodynamic and mathematical analysis of geothermal power plants operating in different climatic conditions. *Case Studies in Thermal Engineering*, 30. doi: 10.1016/j.csite.2021.101727
- [20] Thabit, Q., Nassour, A., & Nelles, M. (2022). Innovative hybrid waste to energy–parabolic trough plant for power generation and water desalination in the Middle East North Africa region: Jordan as a case study. *Energy Reports*, 8, 13150–13169. doi: 10.1016/j.egyr.2022.09.144
- [21] Ziółkowski, P., Madejski, P., Amiri, M., Kuś, T., Stasiak, K., Subramanian, N., Pawlak-Kruczek, H., Badur, J., Niedźwiecki, Ł., & Mikielwicz, D. (2021). Thermodynamic Analysis of Negative CO₂ Emission Power Plant Using Aspen Plus, Aspen Hysys, and Ebsilon Software. *Energies (Basel)*, 14(19). doi: 10.3390/en14196304
- [22] Madejski, P., & Żymelka, P. (2020). Introduction to computer simulation and calculations of energy systems using STEAG Ebsilon® Professional software. Kraków: AGH (in Polish).
- [23] Steag Energy Services, *Ebsilon® Professional 15.00*. <https://www.ebsilon.com/> [accessed 17 Jan. 2024].
- [24] International association for the properties of water and steam, *IAPWS R7-97* (2012). www.iapws.org/relguide/IF97-Rev.html [accessed: 17 Jan. 2024].
- [25] Soave, G. (1971). Equilibrium constants from a modified Redlich-Kwong equation of state. *Chemical Engineering Science*. 27(6), 1197–1203. doi: 10.1016/0009-2509(72)80096-4
- [26] Linstrom, P.J., & Mallard, W.G. (2001). The NIST Chemistry WebBook: A Chemical Data Resource on the Internet. *Journal of Chemical and Engineering Data*, 46(5), 1059–1063, doi: 10.1021/je000236i
- [27] Lisiecka, K. (2017). Gorzów CHP plant is full of good energy. PGE GiEK S.A. Gorzów CHP unit (in Polish)
- [28] Subramanian, N., & Madejski, P. (2023). Analysis of CO₂ capture process from flue-gases in combined cycle gas turbine power plant using post-combustion capture technology. *Energy*, 282. doi: 10.1016/j.energy.2023.128311
- [29] Madejski, P., Chmiel, K., Subramanian, N., Kuś, T. (2022). Methods and Techniques for CO₂ Capture: Review of Potential Solutions and Applications in Modern Energy Technologies. *Energies (Basel)*, 15, 887. doi: 10.3390/en15030887