



Research paper

An assessment of coagulation process efficiency as a pre-treatment for reusing filtration backwash in water treatment plants

Małgorzata Wolska¹, Halina Urbańska-Kozłowska²,
Anna Solipiwo-Pieścik³

Abstract: The growing water deficit around the world contributes to the need to reduce water losses and implement a circular economy. This is the main reason for searching for additional water sources or limiting water losses. In the case of water supply companies, apart from water losses in the distribution system, the greatest amounts of water are used for filter backwashing. The returning of backwash to the drinking water system can be suitable method for recycling of 3–10% of water treated in water treatment plants (WTPs), but high levels of backwash pollution make pretreatment necessary prior to recirculation. Backwash from surface and infiltration water treatment plants is characterized by different level of pollution and types of contaminants, except for microorganisms, which are present in both backwash types. The aim of this study was to evaluate the effectiveness of coagulation as a method of pre-treating backwash before recirculation to the main water treatment system. Prehydrolyzed coagulant is characterized by a higher removal efficiency for all pollutants, which allows the use of smaller doses. Optimal doses were 5 mg/L and 7 mg/L for PAX XL3 and ALS coagulants respectively. Independent of doses and type of coagulants, coagulation and sedimentation processes did not provide enough efficiency of microorganism removal. The results of this study have found that it is necessary to include other processes, especially disinfection, for pre-treating backwash prior to recirculating it to the treatment system. On the other hand, the cost of backwash recirculation is higher than the cost of intake water.

Keywords: coagulants, cost, filter backwashings, pretreatment, recirculation

¹DSc., PhD., Eng., Wrocław University of Technology, Faculty of Environmental Engineering, Wybrzeże Wyspiańskiego 27, 50-370 Wrocław, Poland, e-mail: malgorzata.wolska@pwr.edu.pl, ORCID: 0000-0003-3627-4778

²PhD., Eng., Municipal Water and Sewage Company, Na Grobli 19, 50-421 Wrocław, Poland, e-mail: halina.urbanska@mpwik.wroc.pl, ORCID: 0000-0001-9137-6510

³MSc., Eng., Wrocław University of Technology, Faculty of Environmental Engineering, Wybrzeże Wyspiańskiego 27, 50-370 Wrocław, Poland, e-mail: anna.solipiwo-piescik@pwr.edu.pl, ORCID: 0000-0001-7229-1060

1. Introduction

Water resources in the world decrease every year, which has resulted in the need for water resource protection and the sustainable use of available water. An availability of 1600 m³/year per person is defined as the limit for water stress [1], and per this definition, the number of countries under water stress is increasing every year. A water deficit and high levels of pollution are the most important reasons to reuse and recycle water, especially drinking water. Malta, the Czech Republic, Denmark and Cyprus are the countries with the largest water deficits, while Poland ranks fifth from the bottom in EU [2].

Recycling of backwash from sand filters in water treatment plants is one of the most common methods to limit the amount of sourced water [3] and is now often implemented in WTP by irrigation or recirculation to the main treatment system together with raw water [4]. Washings, next to water losses in distribution systems, constitute the largest water stream that can be reduced and reused. The management of washings is therefore an element of the circular economy, and their reuse requires pre-treatment. The type of processes used for pre-treatment depends on the composition of the washings.

Backwash composition depends on the quality of treating water, its type and backwashing procedure and frequency [5]. Washings generated during the treatment of surface waters are characterized by a significant variability in terms of quantity and composition. Organic compounds, suspended solids and microorganisms are the most commonly identified as problematic contaminants in washings. There is no clear information about impurities that may limit washing reuse and seasonal variability of composition. This is due to differences in the composition of treated water, in particular the types of natural components and anthropogenic contaminants. In general, the types of contaminants present in the washings are similar to raw water, but in higher concentrations. Independent of water sources, backwash is polluted by microorganisms, which results in potential health hazards for consumers in the case of returning untreated backwash to the treatment process [6–8]. The presence of microorganisms is indicated as the most dangerous contamination, especially pathogenic ones for example *Escherichia Coli*, *Salmonella sp.* [9].

Additionally, iron and manganese should be removed from ground water backwash, and organic compounds should also be removed from surface water backwash [7, 10]. Backwash water, which amounts to 3% to 10% of treated water volume, can be reused after pretreatment in unit process or a process trial [11]. Most common processes used for backwash pretreatment are microfiltration, ultrafiltration, coagulation and disinfection [12]. Coagulation is the most inexpensive method of backwash treatment, which allows for the removal of suspended contaminants, organic compounds, and for decreasing the number of microorganisms [9]. Zhou et al [13] show that the efficiency of backwash treatment depends mostly on raw water composition, and coagulation most effectively removes compounds of low molecular weight. A comparison of PAFCl and FeCl₃ coagulants in the pretreatment of sand bed backwash shows a greater effect on colloid destabilization at lower doses for PAFCl [14], along with a higher effectiveness in limiting membrane fouling. Recirculation of the washings constituting 2–5% of treated water to the water treatment system provided an increase in the efficiency of the coagulation processes in removing DOC and UV and reduction in the coagulant dosage [5].

However, there is no information on the selection of the type and dose of the coagulant and the possibility of using this process to pretreat the infiltration water. Therefore, it was justified to carry out studies to assess the effectiveness of the coagulation process in pretreating washings generated in two water treatment plants and to evaluate the conditions for returning these washings to the water treatment system.

The aim of the research was to determine the composition of the washings and their variability, to assess the coagulation process as a pretreatment, and to assess the possibility of increasing water resources including decreasing the costs of recirculation.

2. Research method

The study was carried out in two water treatment plants (WTP), which treat surface and infiltration water respectively. The water treatment trials are shown in Figure 1a and 1b, and the ranges of raw water values are shown in Table 1. The subject of study was sand filtration backwash from both WTP. Each plant generates up to 100,000 m³/month, and the minimum monthly volumes are 50,000 m³ and 70,000 m³, for the surface and infiltration water treatment plant respectively in both cases, the washings in the WTP are discharged into the river as wastewater.

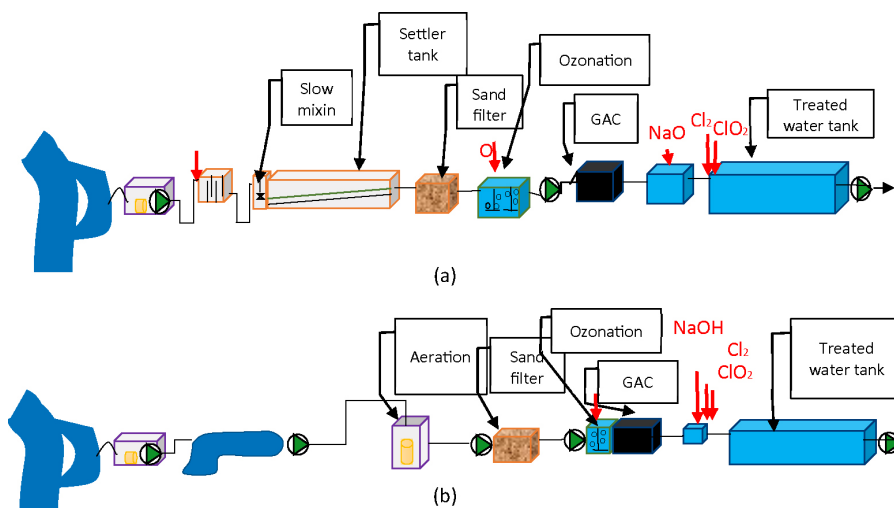

Fig. 1. Surface (a) and infiltration (b) water treatment plant (IWTP) technology

Coagulation and sedimentation were carried out in flow conditions (Fig. 2). The installation worked with capacity 150 L/h, with a contact time in the rapid mixing tank of 90 seconds, a flocculation time of 15 minutes and a sedimentation tank time of one hour. Every six hours, samples were taken before coagulation (raw backwash) and after coagulation and sedimentation in the second, fourth and sixth hour of process. The coagulation parameters were optimized in preliminary tests, the stirrer speed was 120 rpm, and 20 rpm was suitable for fast and slow mixing, respectively.

Table 1. Ranges of water quality parameters in raw surface and infiltration water

Parameter	Unit	Surface water		Infiltration water	
		min	max	min	max
pH	–	7.5	8.1	6.8	7.0
Conductivity	$\mu\text{S/cm}$	340	688	513	689
Color	gPt/m^3	7.0	19.0	6.0	12.0
Turbidity	NTU	2.6	14.0	7.4	18.0
TOC	gC/m^3	3.07	7.79	3.06	5.59
UV ₂₅₄	m^{-1}	6.43	15.00	6.46	9.25
Fe	mgFe/m^3	156	366	808	2,992
Mn	mgMn/m^3	19	238	335	455
Al.	mgAl/m^3	0.00	0.00	0.12	0.12
TNM 22°C	cfu/cm^3	1,200	66,000	10	90
<i>Coli</i>	cfu/100cm^3	2	430	0	0
<i>E.coli</i>	cfu/100cm^3	8	8	0	0
<i>Enterococci</i>	cfu/100cm^3	0	51	0	3
<i>Clostridium perfringens</i>	cfu/100cm^3	10	130	0	0

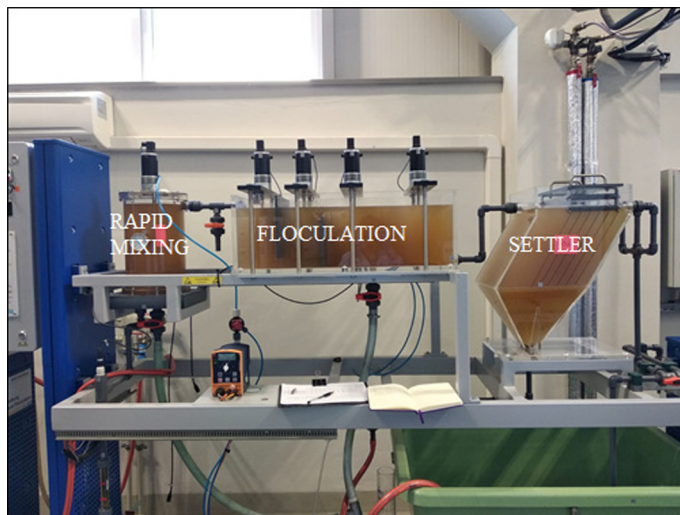

Fig. 2. Installation for coagulation and sedimentation processes

The coagulation and sedimentation in flow conditions allowed for an assessment of differences in effectiveness during the processes and made the results more reasonable and similar to those obtained at full scale. The tests were performed four times a year, which made it

possible to take into account the seasonal variability of the resulting washings and the variability of the effectiveness of coagulants depending on the test conditions, e.g. washings temperature. Each of the tests was repeated three times, and the presented composition analysis results are average values. Flow conditions and coagulant dosages were automatically controlled by the installation device. pH and temperature were measured online for process control. The coagulation process was carried out without adjusting the pH value.

The prehydrolyzed (alkalinity 70%, market name PAX-XL3), and aluminum sulfate (AIS) coagulants efficiencies were evaluated in the dosage ranges of 3–10 gAl/m³, which is similar to those used in other tests of backwash coagulation [15]. The coagulants that were chosen are the same that are used for this process in surface WTP, as reducing the number of coagulants decreases cost. The coagulants used at WTP are effective in removing the contaminants present and have been selected in jar tests for raw surface water.

The pH, conductivity, turbidity (Mt), color, total organic carbon (TOC), UV absorbance at 254 nm and 272 nm, aluminum concentration according to the atomic absorption spectrometry methods (AAS), and the total number of psychrophilic bacteria, mesophilic bacteria, *Escherichia coli*, and *Clostridium perfringens* were analyzed according to standard methods for all samples. Additionally the iron and manganese concentrations were analyzed in samples from the infiltration WTP. PH and conductivity were measured using the potentiometric method with a Hach HQ440d multiparameter. On the other hand, the measurements of iron concentrations were carried out using the spectrometric method with 1,10-phenanthroline and using a Shimadzu 1800UV spectrophotometer, and the same spectrophotometer was used to determine the UV₂₅₄ and UV₂₇₂ absorbance (samples after filtration by 0,45µm filter) and color intensity. The manganese were analyzed by formaldoxime colorimetric method.

A Hach 2100N turbidimeter was used to measure turbidity. The total psychrophilic and mesophilic organism count analysis was performed by culture methods in accordance with current Polish standards (PN-EN ISO 6222), *Escherichia coli* were analyzed with colilert test. Enterococci, and *Clostridium perfringens* were analyzed according to the membrane filtration method. The content of total organic carbon was analyzed by the combustion method using a highly sensitive Shimadzu TOC-L TOC analyzer

The main goal of this research was the analysis of backwash pre-treatment efficiency by coagulation and sedimentation processes with the goal of backwash reuse in the water treatment trial, and to optimize the parameters of the studied processes.

3. Results and discussion

3.1. Backwash from surface water treatment plant (SWTP)

Ranges of quality parameters of raw backwash and backwash after coagulation and sedimentation processes are presented in Table 2 and 3 for AIS and PAX-XL3 respectively.

Values of most quality parameters were in ranges similar to that found in raw surface water. In opposite to the results shown by Suman et al. [16], the backwash total organic content is lower than that of raw intake water. The small TOC variability in raw backwash and a smaller

Table 2. Ranges of quality parameter values for raw and pretreated backwash using the ALS coagulant

Parameter	Unit	Raw backwash	Coagulant dose			
			3 mgAl/L	5 mgAl/L	7 mgAl/L	10 mgAl/L
Turbidity	NTU	54–143	9.3–22.4	8.9–16.0	7.2–13.3	6.5–11.0
Colour	mg Pt/L	8.00–11.04	6.97–7.31	5.85–6.32	5.15–5.79	3.79–4.53
pH	–	7.4–7.6	7.4	7.1–7.2	7.0–7.4	6.8–7.17
Absorbance UV ₂₅₄	m ⁻¹	7.99–11.70	6.97–7.6	7.18–9.02	5.77–2.96	5.08–5.88
Absorbance UV ₂₇₂	m ⁻¹	6.47–8.31	6.33–7.11	5.84–7.34	4.67–4.83	4.14–4.84
TOC	mg/L	3.77–4.37	2.9–3.08	3.56–3.9	3.73–4.06	3.36–3.65
Total number of psychrophilic bacteria	cfu/cm ³	39,000–110,000	25,000–43,000	25,000–33,000	16,000–22,000	18,000–40,000
Total number of mesophilic bacteria	cfu/cm ³	1,800–23,000	1,100–1,500	5,700–6,100	1,280–1,500	5,700–15,000
<i>Escherichia coli</i>	cfu/100cm ³	3–7	1–5	0–5	0–3	0–1
<i>Clostridium perfringens</i>	cfu/100cm ³	1–3	1–2	0–1	0	0
Al	mg/L	0.09–0.18	0.16–0.21	0.16–0.41	0.15–0.28	0.14–0.39

Table 3. Ranges of quality parameter values for raw and pretreated backwash using the PAX-XL3 coagulant

Parameter	Unit	Raw backwash	Coagulant dose			
			3 mgAl/L	5 mgAl/L	7 mgAl/L	10 mgAl/L
Turbidity	NTU	52–108	14.01–27.8	11.0–17.3	4.6–8.5	5.2–8.5
Colour	mg/dm ³ Pt	8.35–9.66	6.22–6.99	5.89–6.39	5.03–6.61	3.56–5.36
pH	–	7.4–7.6	7.4–7.5	7.3–7.5	7.2–7.4	7.1–7.4
Absorbance UV ₂₅₄	m ⁻¹	8.74–12.63	5.99–7.79	5.68–7.01	4.84–5.44	4.64–4.84
Absorbance UV ₂₇₂	m ⁻¹	6.4–6.92	5.8–6.22	5.26–5.03	3.94–4.72	3.72–3.94
TOC	mg/L	4.18–4.64	3.84–4.21	3.82–4.02	3.45–3.89	3.45–3.78
Total number of psychrophilic bacteria	cfu/1 mL	88,000–300,000	32,000–51,000	30,000–43,000	27,000–38,000	27,000–68,000
Total number of mesophilic bacteria	cfu/1 mL	10,000–34,000	7,300–11,500	3,200–7,000	3,200–9,300	3,200–5,500
<i>Escherichia coli</i>	cfu/100 ml	19–360	5–11	0–9	0–3	0–4
<i>Clostridium perfringens</i>	cfu/100 ml	1–44	1–4	1–3	0–1	0
Al	µg/L	0.07–0.20	0.05–0.12	0.05–0.12	0.18–0.19	0.19–0.25

concentration after coagulation can cause an increase in efficiency of removing TOC and its dissolved fraction in the main water treatment system. Similar results were obtained by Suman et al. [16] when the washings were returned at 3–10% of the treated water. Raw backwash was characterized by high numbers of psychrophilic and mesophilic bacteria and turbidity, which should be removed before reusing backwash in the main water treatment process trial. Microbiological pollution is the most often indicated health risk factor in backwash returning to the treatment system [17] and should be eliminated. The numbers of indicator microorganisms were the highest during intake of the high polluted raw surface water, especially during summer.

Coagulation and sedimentation processes allowed for a decrease in all analyzed quality parameters except aluminum, whose concentration increased proportionally to increases in coagulant dose. Increase in Al concentrations were higher after coagulation by ALS. The efficiency of pollution removal was independent of the process time, and similar results were observed at the end of test (6 h). Independent of type of used coagulant and process time, pollutant removal efficiency was stable in time. The efficiency of colour removal was proportional to absorbance and TOC removal (Fig. 3) for PAX XL3 coagulant, but for ALS a correlation between colour and TOC removal was not found. The UV absorbance at 254 nm determines the concentration of refractive organic compounds, which means that during ALS coagulation mostly refractive organic compounds were removed [18], but PAX XL3 allows the removal of all fractions of organic compounds. Deng et al [18] showed that in natural waters, the concentration of refractive organic compounds is proportional to UV absorbance and total organic carbon.

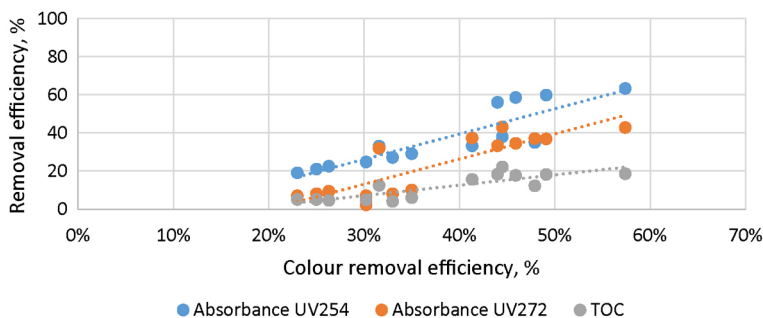

Fig. 3. Correlations between colour removal efficiency and absorbance in UV₂₅₄, UV₂₇₂ or total organic carbon in coagulation by PAX XL3

Efficiencies of TOC removal and decreases in UV₂₅₄ absorbance and colour intensity were between 15% to 57%, and in effect the values of these parameters after coagulation were within the limits for drinking water. Increasing the coagulant doses insufficiently increased pollutant removal efficiently (Fig. 4), however differences between efficiencies of coagulants were small and slightly higher for PAX-XL3.

Used doses of coagulants did not ensure a lowering of turbidity for backwash to the limit for drinking water, but its values were similar to those in raw water and should not negatively affect water treatment efficiency. Obtained efficiencies were smaller than shown by Ebrahimi et al. [14] 99.6 and 99.4% for PAFCl and FeCl₃. These results may suggest that the ferric coagulants are more suitable for backwash pretreatment.

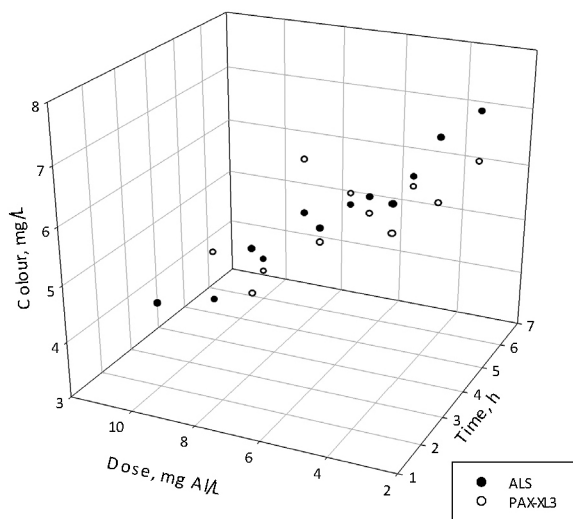

Fig. 4. Influence of coagulants dose and process time on backwash colour

Doses of 5 mg/L PAX-XL3 and 7 mg/L ALS were sufficient to return pretreated backwash into the water treatment system with respect to chemical pollutants, as evidenced by colour, turbidity and organic substances content, except aluminum. On the other hand, aluminum content in backwash recirculation may cause an increased coagulation efficiency in the WTP [5] and should therefore not be the limiting factor for backwash recirculation.

The number of microorganisms in backwash can be a limiting factor for returning it to the water treatment trial [19]. Risks connected with microorganisms present in backwash could be reduced by coagulation, which allows for the removal of psychrophilic and mesophilic microorganisms (Fig. 5), and indicator bacteria (Table 2 and 3).

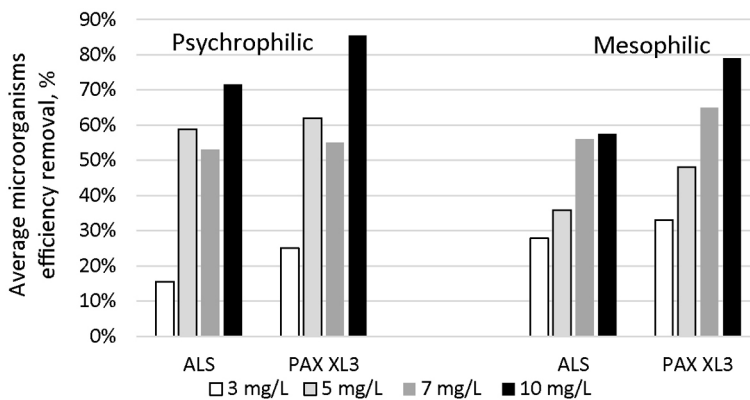

Fig. 5. Average efficiency in microorganism removal during coagulation

In opposite to the results of Mahdavi et al [20] the total number of microorganisms was not proportional to the turbidity of raw and pretreated backwash, and the efficiency of coagulation was lower than that needed for backwash stability and insufficient for full scale implementation.

Microorganism removal efficiency was independent of seasonal variability of backwash composition, which is caused by a greater number of microorganisms in raw and pretreated backwash during summer. This can negatively affect water treatment system effectiveness. The efficiency of mesophilic microorganism removal increases with coagulants doses, independent on coagulant type, but for psychrophilic microorganisms this relation was not found.

Independent of coagulant type and dose, the effectiveness of backwash pretreatment with respect to microorganism removal was insufficient to return backwash to the water treatment system. The pretreated backwash was not free of indicators microorganisms, especially as *Escherichia coli* were found in majority of backwash samples, independent of coagulant type and dose.

3.2. Backwash from infiltration water treatment plant

The composition of raw backwash from the infiltration water treatment plant was characterized high turbidity and iron and manganese content, which were effectively removed during coagulation (Table 4 and 5) many times higher to find in raw water.

Table 4. Ranges of quality parameters values in raw backwash and after coagulation by PAX XL3

Parameter	Unit	Raw backwash	3 gAl/m ³	5 gAl/m ³	7 gAl/m ³	10 gAl/m ³
			3 mgAl/L	5 mgAl/L	7 mgAl/L	10 mgAl/L
Turbidity	NTU	194–332	93–132	69.2–93.8	79.2–92.6	23.2–61.5
Colour	mg/L Pt	8.35–9.66	6.11–6.22	5.03–5.52	5.03–6.61	3.56–5.36
pH	–	7.3–7.6	7.3–7.6	7.3–7.5	7.3–7.4	7.2–7.3
Absorbance UV ₂₅₄	m ⁻¹	7.78–12.63	5.66–5.7	4.84–5.9	4.84–5.44	4.64–4.84
Absorbance UV ₂₇₂	m ⁻¹	6.4–6.9	4.6–4.8	3.94–4.8	3.94–4.72	3.72–3.94
Total organic carbon	mg/L	4.18–4.64	4.09–4.22	3.45–3.77	3.45–3.89	3.45–3.78
Total of psychrophilic microorganisms	cfu/mL	30,000–56,000	17,600–35,000	20,100–16,000	6,200–12,500	2,200–16,600
Total of mesophilic microorganisms.	cfu/ mL	1,100–12,000	5,000–11,000	5,200–8,500	1,100–7,000	140–520
<i>Escherichia coli</i>	cfu/100 mL	0	0	0	0	0
<i>Clostridium perfringens</i>	cfu/100 mL	1–7	0–2	0–1	0–1	0

Continued on next page

Table 4 – Continued from previous page

Parameter	Unit	Raw backwash	3 gAl/m ³	5 gAl/m ³	7 gAl/m ³	10 gAl/m ³
			3 mgAl/L	5 mgAl/L	7 mgAl/L	10 mgAl/L
Fe	mg/L	15.29–24.15	11.34–12.36	7.2–7.77	7.20–9.84	5.54–7.20
Mn	mg/L	2,320–3,303	1.38–1.59	1.33–1.50	1.50–2.10	1.02–1.50
Al	mg/L	0.00	0.05–0.08	0.06–0.09	0.09–0.11	0.11–0.18

Table 5. Ranges of quality parameters values in raw backwash and after coagulation by ALS

Parameter	Unit	Raw Backwash	3 gAl/m ³	5 gAl/m ³	7 gAl/m ³	10 gAl/m ³
Turbidity	NTU	234–543	106–131	89.5–121	119–133	53.6–67.3
Colour	mg/L Pt	8.00–11.04	6.97–7.31	5.85–6.32	6.15–5.79	3.79–4.53
pH	–	7.4–7.6	7.3–7.4	7.1–7.4	7.1–7.3	7.0–7.2
Absorbance UV ₂₅₄	m ⁻¹	7.99–11.70	6.97–7.6	7.18–9.02	5.77–5.96	5.08–5.88
Absorbance UV ₂₇₂	m ⁻¹	6.47–8.31	6.33–7.11	5.84–7.34	4.67–4.83	4.14–4.84
Total organic carbon	mg/L	3.77–4.37	2.9–3.08	3.56–3.9	3.73–4.06	3.36–3.65
Total of psychrophilic microorganisms.	cfu/mL	39,000–110,000	25,000–43,000	25,000–33,000	16,000–22,000	4,000–18,000
Total of mesophilic microorganisms.	cfu/mL	1,800–13,100	3,000–8,700	1,500–6,100	1,280–5,700	1,100–1,500
<i>Escherichia coli</i>	cfu/100 mL	0	0	0	0	0
<i>Clostridium perfringens</i> (together with spores)	cfu/100 mL	1–3	0–2	0–1	0	0
Fe	mg/L	13.09–28.54	8.20–10.09	4.75–9.93	6.58–9.23	3.77–5.35
Mn	mg/L	2.58–4.87	1.37–1.67	1.37–1.67	1.66–2.01	0.81–1.00
Al	mg/L	0.00	0.05–0.12	0.08–0.12	0.18–0.19	0.19–0.25

Backwash colour intensity was caused by organic compounds, especially refractive ones (Fig. 6), which confirms the stated correlation independent of used coagulants and its doses. The effectiveness of colour and organic compounds removal during coagulation was small, and

smaller than that presented by [14], due to the effect of iron and manganese, which are limiting factors in removal of organic compounds. Chaouki et al. [21] show a correlation between the decrease of the value of these parameters, which was not found in the results in this study. This can be explained by high level of pollution or insufficient coagulant doses.

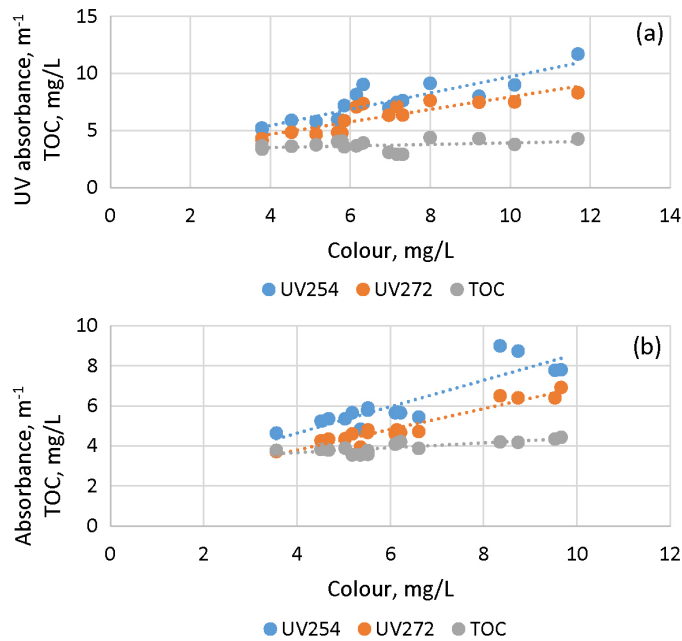

Fig. 6. Correlation between backwash colour and UV absorbance and TOC during coagulation by: (a) PAX XL3, (b) ALS

Turbidity of backwash is the effect of the presence of insoluble iron and manganese compounds (Fig. 7), which are removed from treated water during filtration through a catalytic sand bed. The efficiency of turbidity removal was proportional to iron and manganese removal during coagulation and increases with increased coagulant doses. PAX XL3 effectiveness in iron and manganese removal was slightly higher in comparison to ALS. Concentrations of iron and manganese in pretreated backwash were higher than its contents in raw water, which can be a factor limiting the recirculation to the main water treatment trial, independent of coagulant doses and type of coagulants.

Coagulation, independent on coagulant type and dose, was not a suitable method of pretreating backwash with respect to microorganisms' removal. The decrease in the number of psychrophilic and mesophilic microorganisms was slightly proportional to the decrease in turbidity (Fig. 8), which shows a mechanism of microorganism adsorption in the suspension.

The effectiveness of coagulation for treating backwash from infiltration water treatment was insufficient overall, but can be used as one of many (few) processes in pretreatment trial.

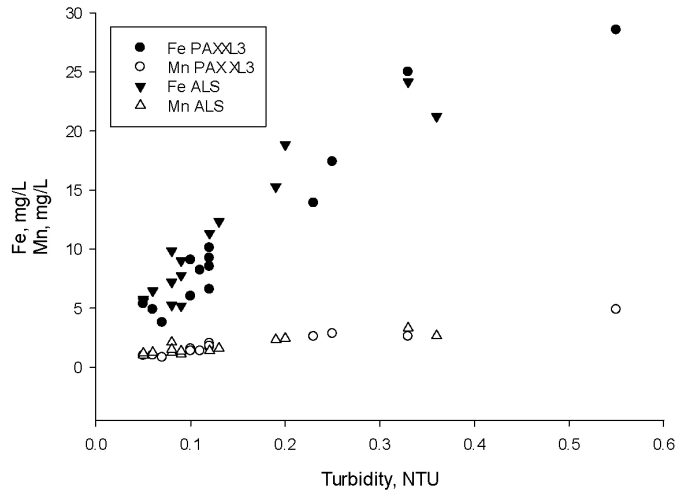

Fig. 7. Correlation between turbidity and iron or manganese content in raw and pretreated backwash

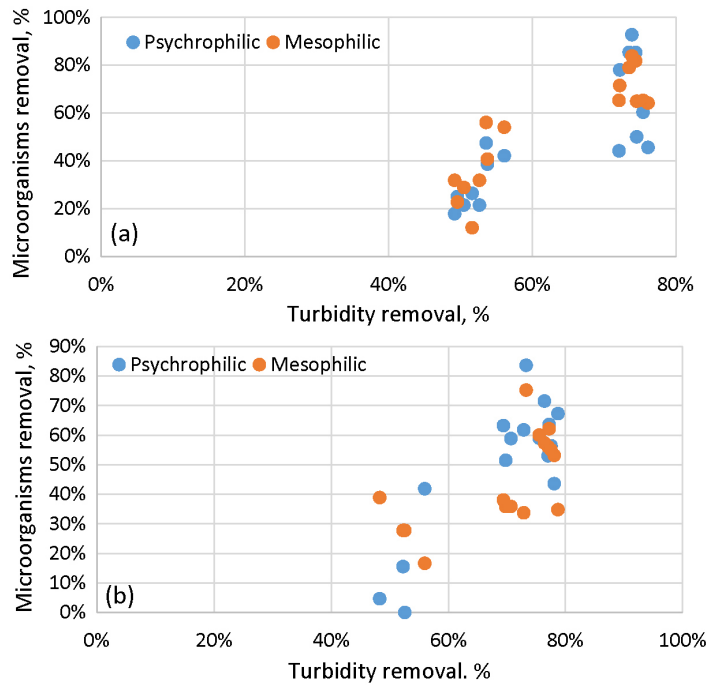

Fig. 8. Influence of turbidity decrease on microorganism removal during coagulation by: (a) ALS, (b) PAX XL3

3.3. Effectiveness of coagulation in backwash pretreatment

In both WTP coagulation allowed for a decrease in all analyzed parameters when used as a backwash pretreatment, especially with respect to microorganisms and suspensions. The ranges of removal effectiveness in optimal conditions (doses of coagulants) are shown in Table 6.

Table 6. Ranges of coagulation effectiveness in backwashing pretreatment

Parameter	Surface WTP		Infiltration WTP	
	PAX XL3	ALS	PAX XL3	ALS
	5 gAl/m ³	7 gAl/m ³	5 gAl/m ³	7 gAl/m ³
Turbidity	84–91%	84–87%	52–64%	61–70%
Colour	32–48%	46–50%	37–41%	46–50%
Absorbance UV ₂₅₄	30–38%	23–39%	32–35%	23–39%
Absorbance UV ₂₇₂	32–43%	12–30%	25–28%	12–30%
TOC	12–22%	8–16%	10–17%	8–16%
Total of psychrophilic microorganisms	57–69%	51–63%	51–71%	52–63%
Total of mesophilic microorganisms	73–91%	34–38%	13–47%	34–38%
<i>Escherichia coli</i>	64–100%	29–100%	–	–
<i>Clostridium perfringens</i>	0–100%	0–100%	0–100%	0–100%
Iron	62–67%	64–92%	49–66%	60–81%
Manganese	11–25%	13–52%	43–53%	35–47%

The prehydrolyzed coagulant was characterized by a higher effectiveness in backwash pretreatment, similar to results presented by Mazari [15]. Independent of coagulant type and its dose, the efficiency in removing organic compounds was low. On the other hand, microorganisms, which are the most dangerous backwash pollutant, were eliminated in wide range, especially pathogenic *Clostridium perfringens*. However, the numbers of all types of analyzed microorganisms were too high to return pretreated backwash into the treatment trial [22]. Methods of pretreatments cannot be the same in both types of backwash, as infiltration WTP backwash needs a more advanced pretreatment system.

Backwash from surface WTP needs disinfection except the coagulation ones.

Additionally the effectiveness in removing organic compounds in both types of backwash was low, and also can be a limiting factor in case of higher organic pollution levels of raw water.

An assessment of pretreatment costs was made on the basis of present prices of coagulants, without the investment costs, since the settler tanks are elements of wastewater management in both WTP, and can be used to implementation of sedimentation process. Coagulants can be introduced before this elements directly into the pipeline. Investment cost in both WTP include only the coagulant pump system.

Coagulant costs independent of type are similar – 0.0033 euro/gAl and 0.003 euro/gAl for PAX-XL3 and AIS respectively.

According to the amount of backwash generation monthly in surface and infiltration water treatment plants and optimal doses of coagulants, the coagulation costs are 825 euro and 1155 euro for surface and infiltration WTPs for PAX-XL3, but for ALS the cost is 1050 and 1470 euro for surface and infiltration water respectively. On the other hand the costs of intake (cost includes intake water and sewage discharge) for a similar amount of raw water are 645 euro/month and 902 euro/month for surface and infiltration WTP. In conclusion the recirculation of pretreated backwashing after coagulation is reasonable only in case of a deficit of water, especially if other washings pretreatment processes are required.

4. Conclusions

1. The Coagulation process is suitable for removing colloids and suspensions from backwash, but the improvement in water quality parameters is not sufficient to recirculate backwash into the main water treatment system.
2. The slightly more effective coagulant in both WTP was PAX XL3, whose optimal dose was 5 mgAl/L, with a similar effect obtained with 7 gAl/L for ALS, with increased doses not causing significant increases in efficiency.
3. Backwash from infiltration WTP contains insoluble iron and manganese compounds and microorganisms which should be removed before returning it to the water treatment system.
4. Backwash from surface water contains high number of psychrophilic, mesophilic and indicator microorganisms which limits the return of backwash to the treatment system, and should be removed during a disinfection process.
5. Backwash from infiltration water is characterized by a higher level of chemical pollutants, while surface backwash contains a many times higher number of microorganisms.
6. Coagulation cannot be the only pretreatment process, and other pretreatment processes are necessary. Infiltration backwash needs a more complicated pretreatment system, but surface backwash can be pretreated with coagulation and disinfection processes.
7. Coagulant costs for backwash pretreatment in both WTP are higher than the cost of intake water and sewage discharge but recirculation of pretreated backwash can increase water resources.

References

- [1] A.Their, I. Tyli, and K. Żmija, “Management of water resources and their consumption within the circular economy”, in *Restructuring management: Models–Changes–Development*. Cracow University of Economics, 2020, pp. 203–226.

- [2] M. Gromiec, "Nowe koncepcje gospodarki wodno-ściekowej-osadowej" in *Ocena gospodarki ściekowo-osadowej w Polsce*, Monografie Komitetu Inżynierii Środowiska PAN, vol. 166, 2020.
- [3] EPA United States Environmental Protection Agency, Drinking Water Treatment Plant Residuals Management Technical Report, Summary of Residuals Generation, Treatment, and Disposal at Large Community Water Systems, 2011.
- [4] M. Zielina and W. Dąbrowski, "Energy and water savings during backwashing of rapid filter plants", *Energies*, vol. 14, no. 13, art. no. 3782, 2021, doi: [10.3390/en14133782](https://doi.org/10.3390/en14133782).
- [5] A. Gottfried, A. D. Shepard, K. Hardiman, and M. E. Walsh, "Impact of recycling filter backwash water on organic removal in coagulation–sedimentation processes", *Water Research*, vol. 42, no. 18, pp. 4683–4691, 2008, doi: [10.1016/j.watres.2008.08.011](https://doi.org/10.1016/j.watres.2008.08.011).
- [6] M. L. Jibhakate, M. P. Bhorkar, A. G. Bhole, and P. K. Baitule, "Reuse & recirculation of filter backwash water of water treatment water", *International Journal of Engineering Research and Applications*, vol. 7, no. 4, pp. 60–63, 2017, doi: [10.9790/9622-0704016063](https://doi.org/10.9790/9622-0704016063).
- [7] M. Wołowiec, A. Pruss, M. Komorowska-Kaufman, I. Lasocka-Gomuła, G. Rzepa, and T. Bajda, "The properties of sludge formed as a result of coagulation of backwash water from filters removing iron and manganese from groundwater", *SN Applied Sciences*, vol. 1, no. 6, art. no. 639, 2019, doi: [10.1007/s42452-019-0653-7](https://doi.org/10.1007/s42452-019-0653-7).
- [8] D. Wang, J. Zhou, H. Lin, J. Chen, J. Qi, Y. Bai, and J. Qu, "Impacts of backwashing on micropollutant removal and associated microbial assembly processes in sand filters", *Frontiers of Environmental Science and Engineering*, vol. 17, no. 3, 2023, doi: [10.1007/s11783-023-1634-z](https://doi.org/10.1007/s11783-023-1634-z).
- [9] W. Li, X. Liang, J. Duan, S. Beechamb, and D. Mulcahy, "Influence of spent filter backwash water recycling on pesticide removal in a conventional drinking water treatment process", *Environmental Science Water Research and Technology*, vol. 4, no. 7, pp. 1057–1067, 2018, doi: [10.1039/C7EW00530J](https://doi.org/10.1039/C7EW00530J).
- [10] M. Komorowska-Kaufman, F. Ciesielczyk, A. Pruss, and T. Jesionowski, "Effect of sedimentation time on the granulometric composition of suspended solids in the backwash water from biological activated carbon filters", *E3S Web of Conferences*, vol. 44, art. no. 00072, 2018, doi: [10.1051/e3sconf/20184400072](https://doi.org/10.1051/e3sconf/20184400072).
- [11] M. Zemite, L. Mezule, K. Gruskevica, et al., "Affordable Pretreatment Strategy for Mitigation of Bio-fouling in Drinking-Water Systems", *Journal of Environmental Engineering*, vol. 148, no. 2, 2022, doi: [10.1061/\(ASCE\)EE.1943-7870.0001968](https://doi.org/10.1061/(ASCE)EE.1943-7870.0001968).
- [12] F. H. de Souza, B. S. Pizzolatti, and M. L. Sens, "Backwash as a simple operational alternative for small-scale slow sand filters: From conception to the current state of the art", *Journal of Water Process Engineering*, vol. 40, art. no. 101864, 2021, doi: [10.1016/j.jwpe.2020.101864](https://doi.org/10.1016/j.jwpe.2020.101864).
- [13] Z. Zhou, Y. Yang, X. Li, Z. Su, Y. Liu, J. Ren, and Y. Zhang, "Effect of recycling filter backwash water on characteristic variability of dissolved organic matter in coagulation sedimentation process", *Desalination and Water Treatment*, vol. 53, no. 1, pp. 48–56, 2015, doi: [10.1080/19443994.2013.836994](https://doi.org/10.1080/19443994.2013.836994).
- [14] M. M. Ebrahimi, H. Amin, Y. Pourzamani, A. H. Hajizadeh, M. M. Mahvi, and M. H. R. Rad, "Hybrid coagulation-UF processes for spent filter backwash water treatment: a comparison studies for PAFCl and FeCl₃ as a pre-treatment", *Environmental Monitoring and Assessment*, vol. 189, pp. 1–15, 2017, doi: [10.1007/s10661-017-6091-3](https://doi.org/10.1007/s10661-017-6091-3).
- [15] L. Mazari and D. Abdessemed, "Feasibility of Reuse Filter Backwash Water as Primary/Aid Coagulant in Coagulation–Sedimentation Process for Tertiary Wastewater Treatment", *Arabian Journal for Science and Engineering*, vol. 45, no. 9, pp. 7409–7417, 2020, doi: [10.1007/s13369-020-04597-1](https://doi.org/10.1007/s13369-020-04597-1).
- [16] S. Suman, N. P. Singh, and Ch. Sulekh, "Effect of Filter Backwash Water when blends with Raw Water on Total Organic Carbon and Dissolve Organic Carbon Removal", *Research Journal of Chemical Sciences*, vol. 2, no. 10, pp. 38–42, 2012.
- [17] C. Rodrigues and M. A. Cunha, "Assessment of the microbiological quality of recreational waters: indicators and methods", *Euro-Mediterranean Journal for Environmental Integration*, vol. 2, pp. 1–18, 2017, doi: [10.1007/s41207-017-0035-8](https://doi.org/10.1007/s41207-017-0035-8).
- [18] L. Deng, H. H. Ngo, W. Guo, and H. Zhang, "Pre-coagulation coupled with sponge-membrane filtration for organic matter removal and membrane fouling control during drinking water treatment", *Water Research*, vol. 157, pp. 155–166, 2019, doi: [10.1016/j.watres.2019.03.052](https://doi.org/10.1016/j.watres.2019.03.052).

- [19] L. Fu, C. Wu, Y. Zhou, J. Zuo, and Y. Ding, "Investigation on evaluation criteria of backwashing effects for a pilot-scale BAF treating petrochemical wastewater", *Environmental Technology*, vol. 38, no. 20, pp. 2523–2533, 2017, doi: [10.1080/09593330.2016.1269838](https://doi.org/10.1080/09593330.2016.1269838).
- [20] M. Mahdavi, M. Mehdi Amin, A. Hossein Mahvi, H. Pourzamani, and A. Ebrahimi, "Metals, heavy metals and microorganism removal from spent filter backwash water by hybrid coagulation-UF processes", *Journal of Water Reuse and Desalination*, vol. 8, no. 2, pp. 225–233, 2018, doi: [10.2166/wrd.2017.148](https://doi.org/10.2166/wrd.2017.148).
- [21] Z. Chaouki, I. El Mrabet, F. Khalil, M. Ijjaali, S. Rafqah, S. Anouar, and H. Zaitan, "Use of coagulation-flocculation process for the treatment of the landfill leachates of Casablanca city (Morocco)", *Journal of Mater Environment Science*, vol. 8, pp. 2781–2791, 2017.
- [22] G. Saxena, R. N. Bharagava, G. Kaithwas, and A. Raj, "Microbial indicators, pathogens and methods for their monitoring in water environment", *Journal of Water and Health*, vol. 13, no. 2, pp. 319–339, 2015, doi: [10.2166/wh.2014.275](https://doi.org/10.2166/wh.2014.275).

Ocena skuteczności procesu koagulacji w podczyszczaniu popłuczyn w celu ponownego ich wykorzystania w stacjach uzdatniania wody

Słowa kluczowe: koagulant, koszty, popłuczyny, recykulacja

Streszczenie:

Rosnący deficyt wody na całym świecie przyczynia się do konieczności ograniczania jej strat i wdrażania gospodarki o obiegu zamkniętym. Jest to główny powód poszukiwania dodatkowych źródeł wody lub ograniczania jej strat. W przypadku przedsiębiorstw wodociągowych, oprócz strat wody w systemie dystrybucji, największe ilości wody wykorzystywane są do płukania filtrów. Zawracanie popłuczyn do systemu oczyszczania wody do picia może być odpowiednią metodą odzysku 3–10% wody uzdatnionej w zakładach oczyszczania wody (ZOW), ale wysoki poziom zanieczyszczenia popłuczyn sprawia, że przed recykulacją konieczne jest ich wstępne podczyszczenie. Popłuczyny z zakładów oczyszczania wód powierzchniowych i infiltracyjnych charakteryzują się różnym poziomem zanieczyszczenia i rodzajami zanieczyszczeń, z wyjątkiem mikroorganizmów, które są obecne w obu typach popłuczyn. Celem tych badań była ocena skuteczności koagulacji jako metody wstępnego oczyszczania popłuczyn przed recykulacją ich do głównego systemu uzdatniania wody. Badania wykazały, że wstępnie zhydrolizowany koagulant charakteryzuje się wyższą skutecznością usuwania wszystkich zanieczyszczeń, co pozwala na stosowanie mniejszych dawek niż hydrolizującego siarczanu glinu. Optymalne dawki wynosiły odpowiednio 5 mg/l i 7 mg/l dla koagulantów PAX XL3 i ALS. Niezależnie od dawek i rodzaju stosowanych koagulantów, procesy koagulacji i sedymentacji nie zapewniały wystarczającej skuteczności usuwania mikroorganizmów. Wyniki badań wykazały, że konieczne jest włączenie innych procesów, zwłaszcza dezynfekcji, do wstępnego podczyszczania popłuczyn przed ponownym wprowadzeniem ich do systemu oczyszczania. Z drugiej strony, koszt recykulacji popłuczyn jest wyższy niż koszt ujęcia wody i odprowadzenia popłuczyn do środowiska jako ścieków.

Received: 2023-08-09, Revised: 2024-02-08